

Instructions for 32", 46", 58", & 70" Red Cedar Contoured Backed Bench

Tools Required for Assembly

7/16" Socket or Adjustable Wrench
2# Squarehead Bit (included)
Hammer for tapping bolts and screws.
Tape Measure

Hardware List

8- 1/4 x 3" Hex Bolts
8- 1/4" Hex Nuts
16- 1/4 x 1" Fender Washers
6- 3" Screws
4- 2 1/2" Screws
18- 2" Screws
3- 1 1/4" Screws

Parts List

1- Bench Top
2- Bench Legs
2- Bench Back Boards
1- Back Support

Hex Bolts

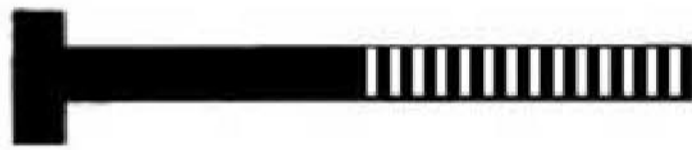

Screw



Fender Washer



Nut

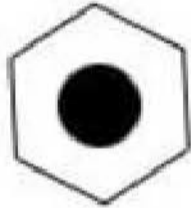

Pre-drilled Hole 

Step 1.

Lay the bench upside down on a clean flat surface. We recommend using the box the item was shipped in. Using 3" bolts, attach each leg on the outside, aligning it with the pre drilled holes. Tighten the bolts.

Step 2:

Now put the 3" screws in the small pre-drilled holes.

Step 3:

Tip the bench on its side and place the bench legs on the outside of the bench, align holes, tighten bolts, and put 2 1/2" screws in small pre-drilled holes.

Step 4.

Tip the bench on its back and put the wide board onto the legs keeping it even on top. Use 2" screws for bottom and middle predrilled holes and 1 1/4" screws for the very top predrilled holes. Now put the smaller board on the bottom. Measure 3 3/8" in between the wide board and the small bottom board, and add the small middle board between those two. Attach the back support onto the back, center of the bench by using the 1 1/4" screws in the predrilled holes on the back support. (see image on next page)

Instructions for 32", 46", 58", & 70" Red Cedar Contoured Backed Bench

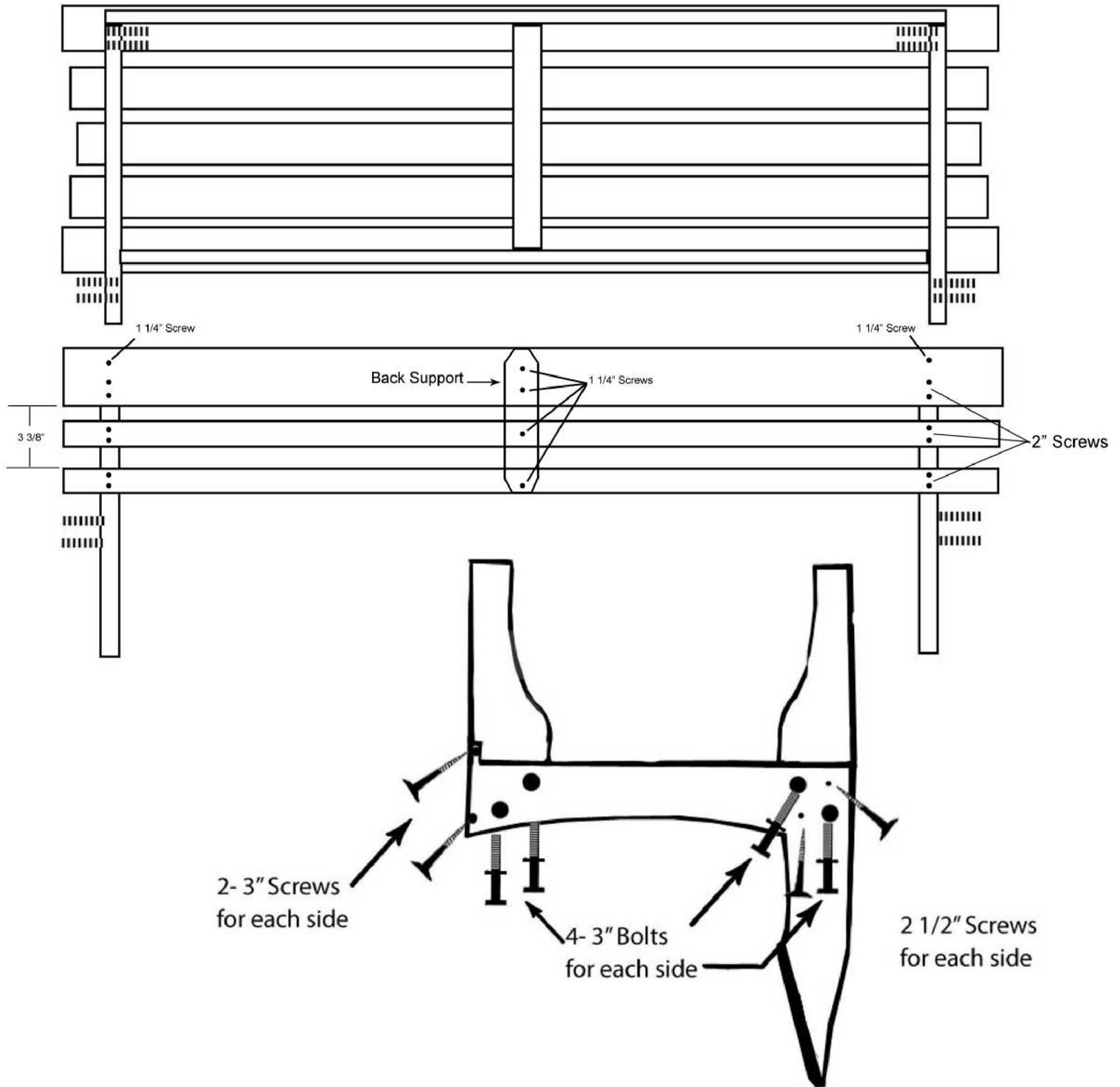

Instructions for 94" Red Cedar Contoured Backed Bench

Tools Required for Assembly

7/16" Socket or Adjustable Wrench
2# Squarehead Bit (included)
Hammer for tapping bolts and screws.
Tape Measure

Hardware List

8- 1/4 x 3" Hex Bolts
8- 1/4" Hex Nuts
16- 1/4 x 1" Fender Washers
4- 3" Screws (Front Legs)
4- 2 1/2" Screws (Back Legs)
18- 2" Screws (Back Seat Slats
middle, bottom, and+ 2 lower holes
of top slats)
6- 1 1/4" Screws

Hex Bolts



Screw



Fender Washer



Nut

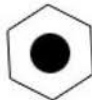

Pre-drilled Hole



Parts List

1- Bench Top
2- Bench Legs (Front)
3- Bench Back Boards
1- Back Support
2- Back Legs

Step 1.

Lay the bench upside down on a clean flat surface. We recommend using the box the item was shipped in. Using 3" bolts, attach each leg on the outside, aligning it with the pre drilled holes. Tighten the bolts.

Step 2:

Now put the four (4) 3" screws in the small pre-drilled holes in the front legs. (2 each side)

Step 3:

Tip the bench on its side and place the bench back legs on the outside of the bench, align holes, tighten bolts, and put four (4) 2 1/2" screws in small pre-drilled holes. (2 in each Leg)

Step 4.

Tip the bench on its back and put the wide board onto the leg back support keeping it even on top. Please note the pre-drilled holes are only on the slats not the legs. Use 2" screws for bottom and middle pre-drilled holes and 1 1/4" screws for the very top predrilled holes. Now put the smaller board on the bottom. Measure 3 3/8" in between the wide board and the small bottom board, and add the small middle board between those two. Attach the back support onto the back, center of the bench by using the 1 1/4" screws in the predrilled holes on the back support. (see image on next page)

Instructions for 94" Red Cedar Contoured Backed Bench

Bottom of Seat Bench

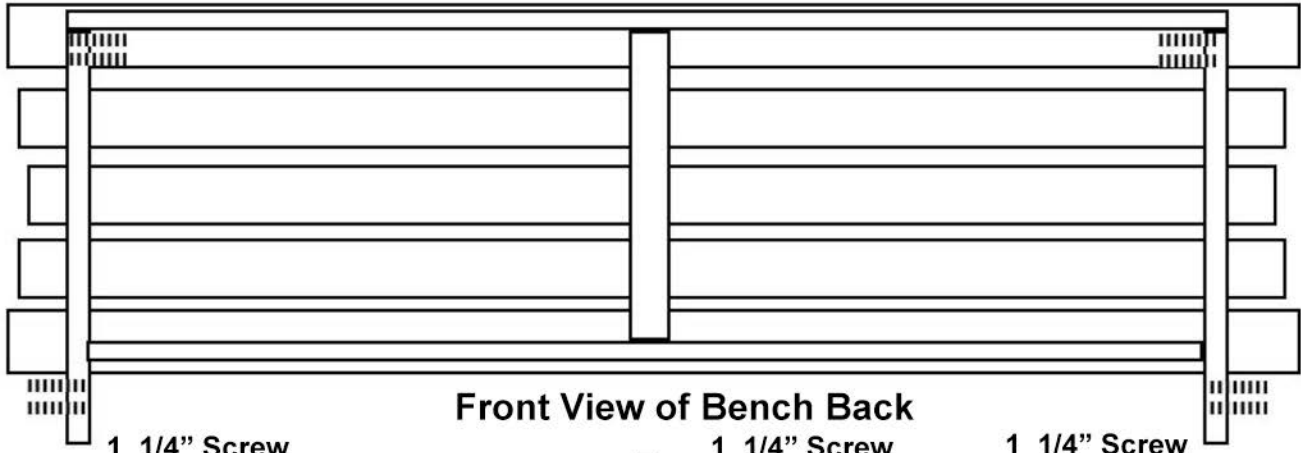

Front View of Bench Back

