

Please check contents **before assembly**. If any items are missing or damaged, **do not take the unit back to the store**. Call 1-800-427-5136 for customer service and we will save you time by correcting any problems directly for you.

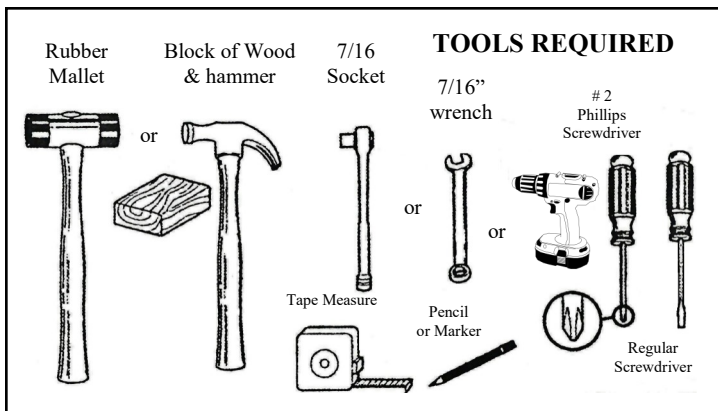
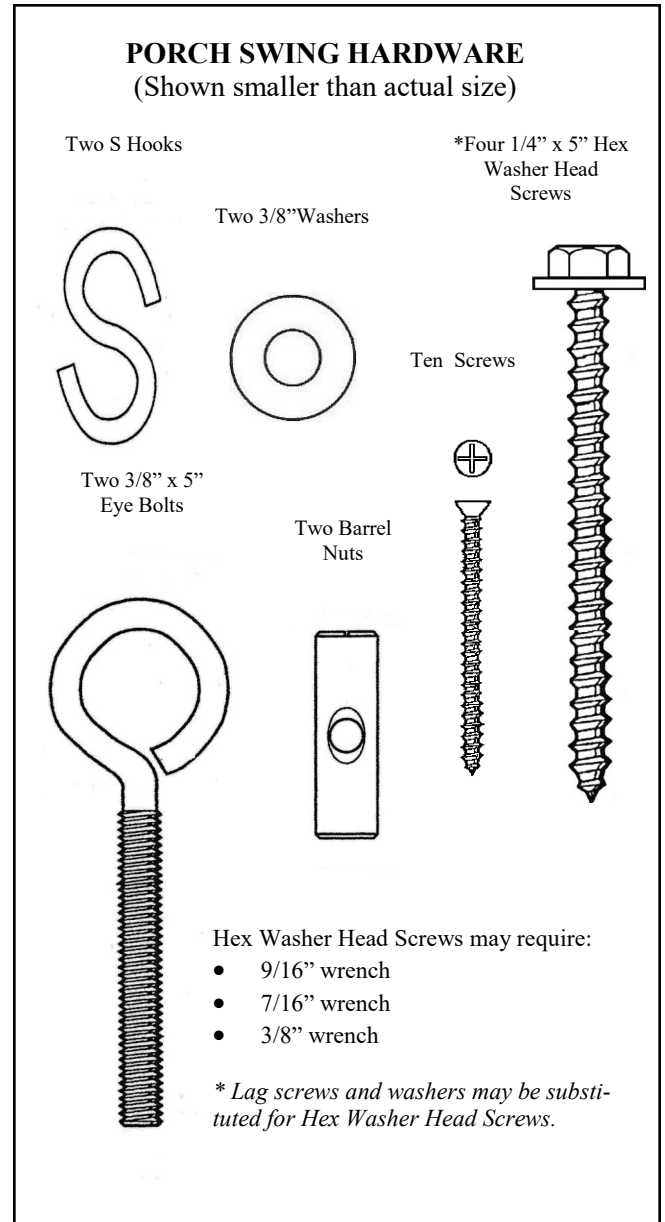
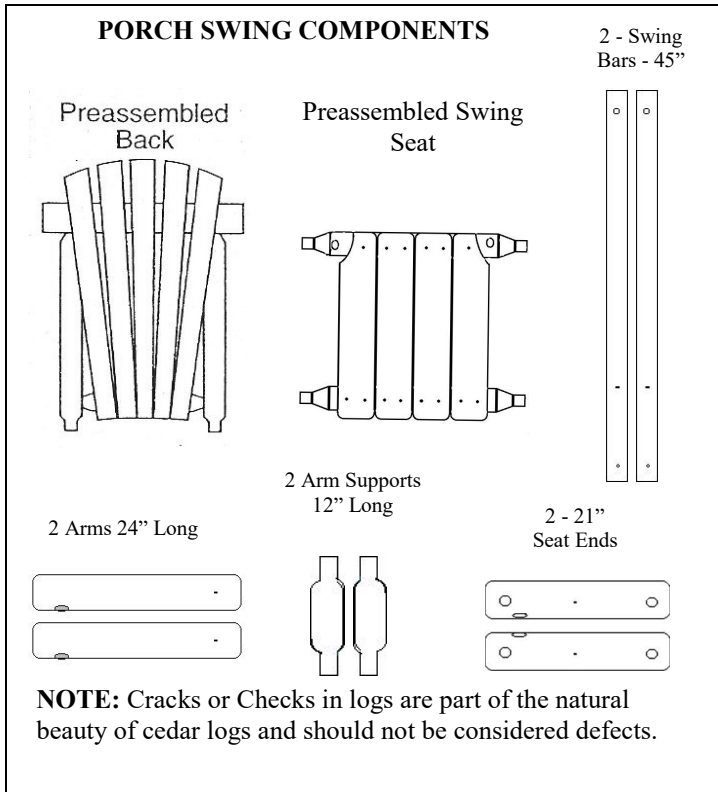

**NOTE** Read all instructions before starting.

- To start hex washer head screws, hammer into wood about 1/2", then use wrench to tighten.
- Do not completely tighten any screws until the unit is fully assembled and setting on a level surface.
- Use a rubber mallet (or block of wood between the hammer and the unit) to drive doweled ends into holes as far as possible.
- A battery or power screw gun will make assembly easier and quicker.

#### STEP 1

Install seat ends onto seat. Align holes in seat end with dowels on seat as shown in picture at right. Repeat on other side. Secure with screws perpendicular to dowel. **IMPORTANT:** The single hold should be place toward the front of the seat.

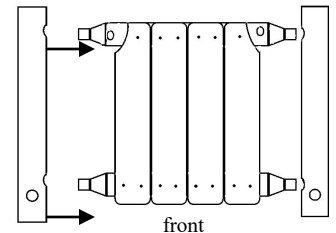

**Please Note:** After you have installed the seat ends onto the seat, secure with (4) 2 1/2" screws. See figures at left.

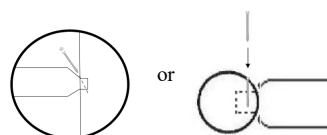

**STEP 2** Lay assembled seat on ground. Insert doweled ends of uprights of the assembled back into the 1 1/4" holes in the back rail of the seat (*adjusting uprights in or out as needed to align properly with holes*). **Do not tap on seat back with hammer.**

To keep the back rail from splitting, lay the back on the ground and drive the seat on by hitting the bottom of the seat assembly. Figure 1.

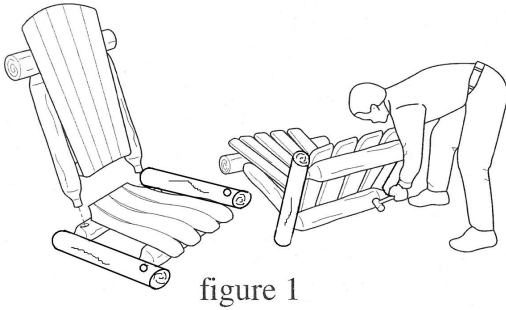

figure 1

**STEP 3** Insert the 12" arm support into the 1 1/2" hole in the arm, then insert other end of arm support into the hole of the seat end. Drive dowels in as far as possible.

Fasten arm to back frame. Align the predrilled hole in the back of the arm with the predrilled hole of the back upright. The back upright has a preinstalled lag bolt, tighten the 1/4" x 5" lag screw into the pilot hole of the arm with a wrench, socket, or power drill. Repeat process for the other arm. Figure 2.

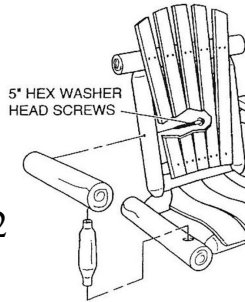

figure 2

**STEP 4** Secure all dowel joints in place with screws perpendicular to the doweled end as shown. Figure 3

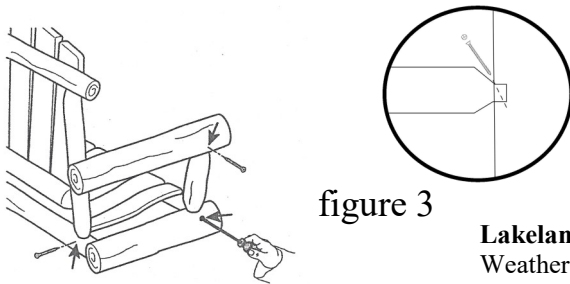
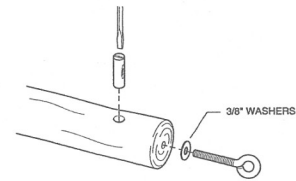

figure 3

**STEP 5** Place barrel nut into horizontally drilled hole in top end of swing bar. Position barrel nut with screwdriver and screw in 5" eyebolt with 3/8" washer as shown. **TIGHTEN DOWN SECURELY!** Repeat process for other swing bar. Figure 4

figure 4



**STEP 6** Fasten swing bars to side of unit as shown in figure 5. Measure 15" from the back of each arm and mark with pencil. (This gives a suggested pitch of the seat. You may change the pitch by altering the location of the lag screw in the arm.) With hammer, tap a 5" hex washer head screw through the bottom hole in swing bar and into pilot hole in seat end. Tap a 5" hex washer head screw through the upper hole in the swing bar and into the arm about 1/2" deep at the pencil marked position on the arm. Tighten down lag screws.

figure 5

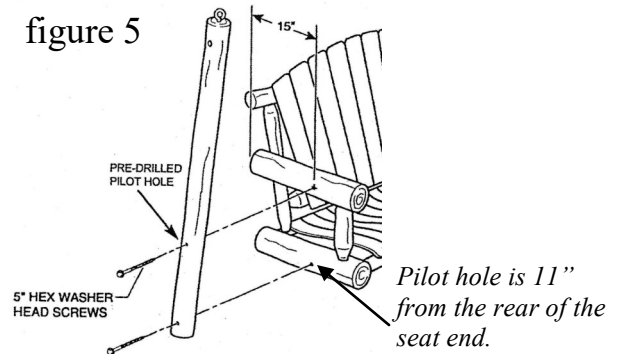

*If you have hardware left over after completing your unit, it most likely has been assembled incorrectly, and may not be safe to use. Please call Customer Service at 800-427-5136 for assistance.*

**NOTE: Check all nuts and bolts for tightness before and during each usage season.**

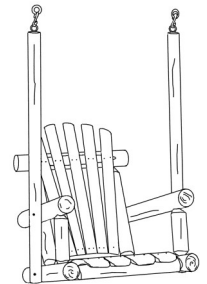

**Lakeland Mills recommends:**  
WeatherSeal Premium Oil-Based Exterior Wood Stain & Sealant

[www.ContinentalProd.com](http://www.ContinentalProd.com)

Look for videos on:



<https://www.youtube.com/watch?v=jg2BRqWMVpg&t=1s>

Like  
Lakeland  
Mills  
on

