

CFU18 - 4' Yard Swing

Please check contents **before** assembly. If any items are missing or damaged, **do not take the unit back to the store.** Call 1-800-427-5136 for customer service and we will save you time by correcting any problems directly for you.

A-FRAME COMPONENTS

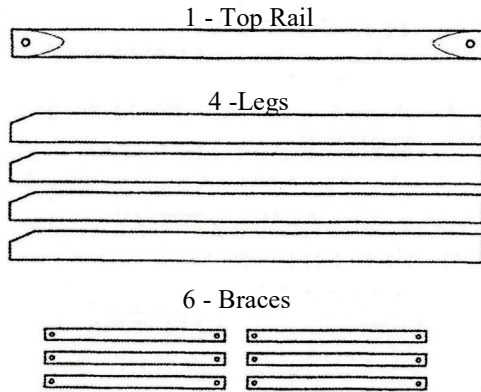

NOTE: Cracks or Checks in logs are part of the natural beauty of cedar logs and should not be considered defects.

Tools that May Be Needed

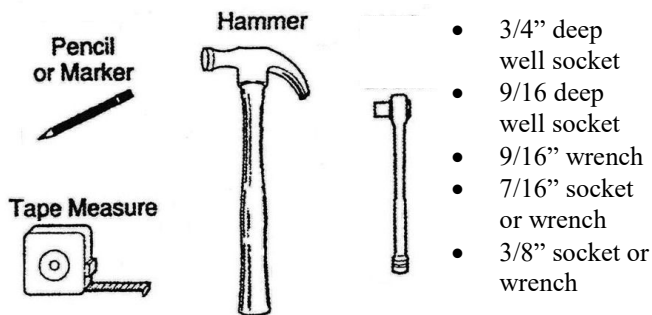

NOTE:

- Read all instructions before starting.

Helpful Tips:

- To start hex washer head screws, hammer into wood about 1/2" then use wrench or socket to tighten.
- Do not completely tighten any screws until the unit is fully assembled and setting on a level surface.
- If you have hardware left over after completing your unit, it most likely has been assembled incorrectly, and may not be safe to use. Please call Customer Service at 1-800-427-5136, for assistance.
- **Check all nuts and bolts for tightness before and during each usage season.**

A-FRAME HARDWARE (Shown smaller than actual size)

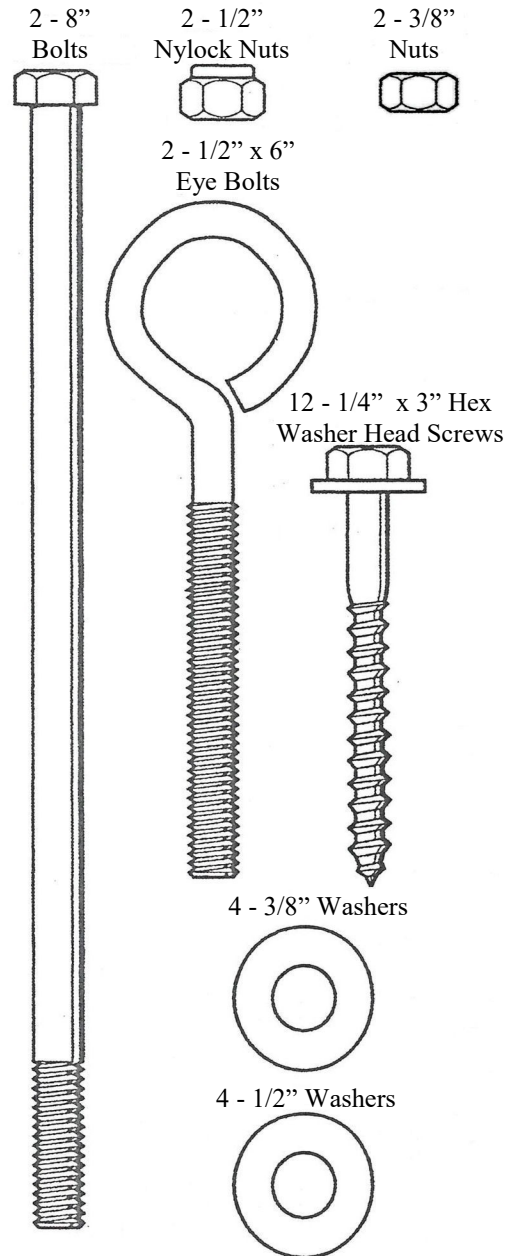

A-FRAME ASSEMBLY

- STEP 1** See figure 1A. Place a 1/2" washer on the 6" eye bolt. Drive the eye bolt through the hole in top rail, on the opposite side from the counterbore. Place 1/2" washer on the 6" eye bolt in the counterbore, then place nylock nut on the eye bolt in the counterbore. Tighten with 3/4" socket. Repeat this process on the other side. See figure 1B Lay top rail on the ground with eye bolts down. Lay top of legs parallel to top rail as shown in figure 1B and attach all legs with 8" bolts, 3/8" washers, and nuts, using a washer on both ends of the bolt. Repeat process on opposite side. **DO NOT TIGHTEN YET.**

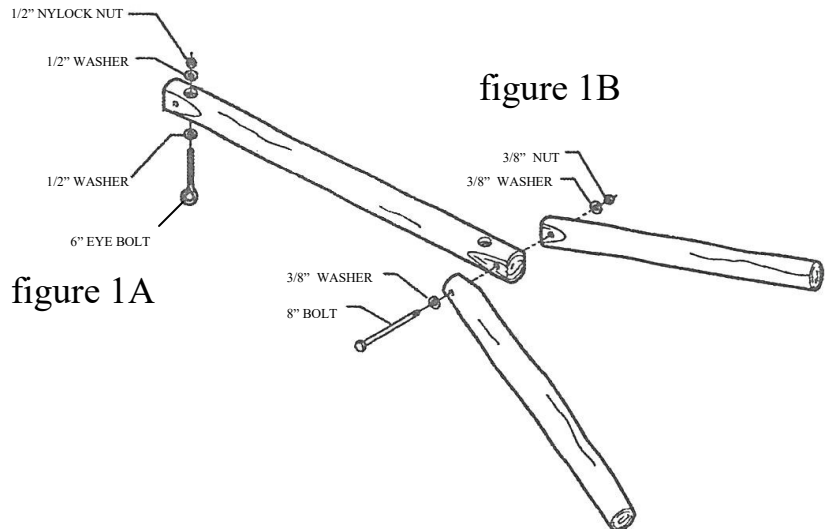

- STEP 2** Pre-measure and mark rail and legs for braces. Mark position of leg braces 32" from the top of the legs as illustrated in figure 2. Mark position of rail to leg brace 22 1/2" from the end of top rail and 24" from the top of legs as shown in figure 2.

This will set your swing seat at an average height from the ground. If you wish to raise the seat higher, attach leg braces more than 32" from the top of the legs. To lower the seat height, attach them at a point less than 32" from the top of the legs.

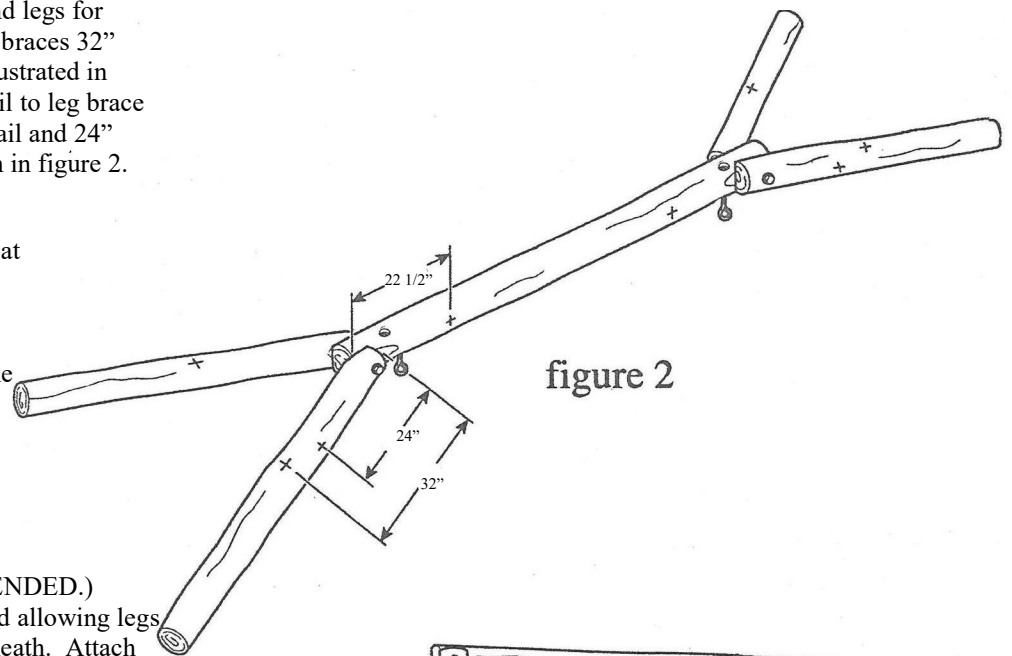

- STEP 3** (TWO PEOPLE RECOMMENDED.) Lift top rail with legs attached allowing legs to swing into position underneath. Attach braces (as illustrated in figure 3) to pre-marked positions tapping 3" hex washer head screws with a hammer to start them into legs and tightening them with a 7/16" wrench. After all 6 braces are attached and frame is setting on firm level surface, tighten them securely. Now tighten the nuts and bolts that attach the legs to the top rail with 9/16" wrench, making sure bolts are **TIGHT**.

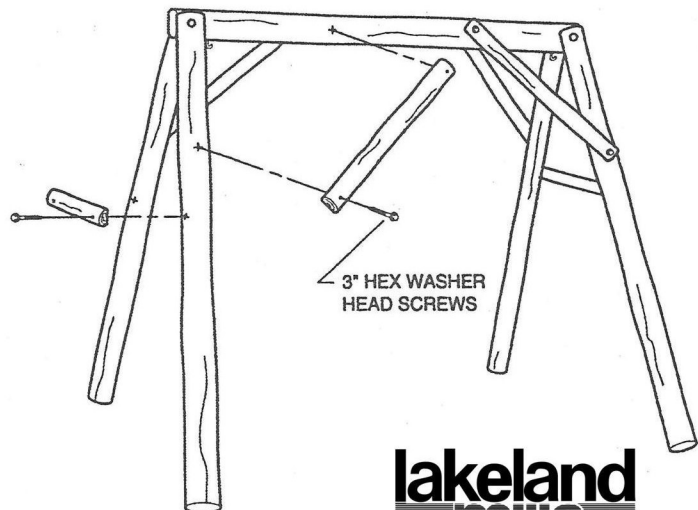

- STEP 4** Tighten all lag screws firmly. Your unit is now ready for finishing or immediate use. Relax and enjoy!

figure 3

**lakeland
mills**



CF1123 & CF1124 CEDAR LOG PORCH SWING

Please check contents **before** assembly. If any items are missing or damaged, **do not take the unit back to the store.** Call 1-800-427-5136 for customer service and we will save you time by correcting any problems directly for you.

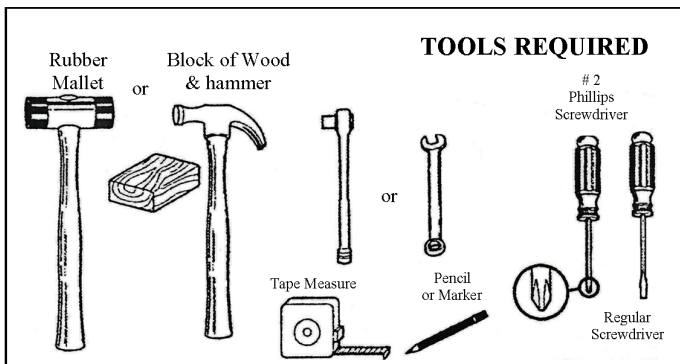
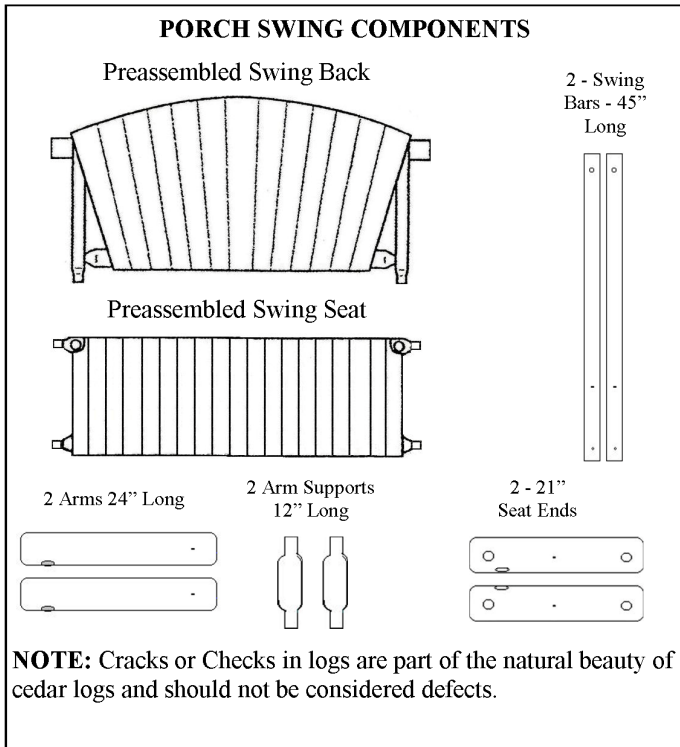

NOTE:

- Read all instructions before starting.
- To start lag screws, hammer into wood about 1/2" then use wrench to tighten.
- Do not completely tighten any screws until the unit is fully assembled and setting on a level surface.
- Use a rubber mallet (or a block of wood between the hammer and the unit) to drive doweled ends into holes as far as possible.

STEP 1 Install seat end onto seat. Align holes in seat end with dowels on seat as shown in picture right. Repeat on other side. Secure with screws perpendicular to dowel.

IMPORTANT: The single hole should be placed toward the front for the seat. (See figure right).

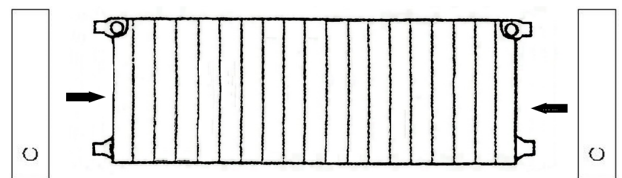
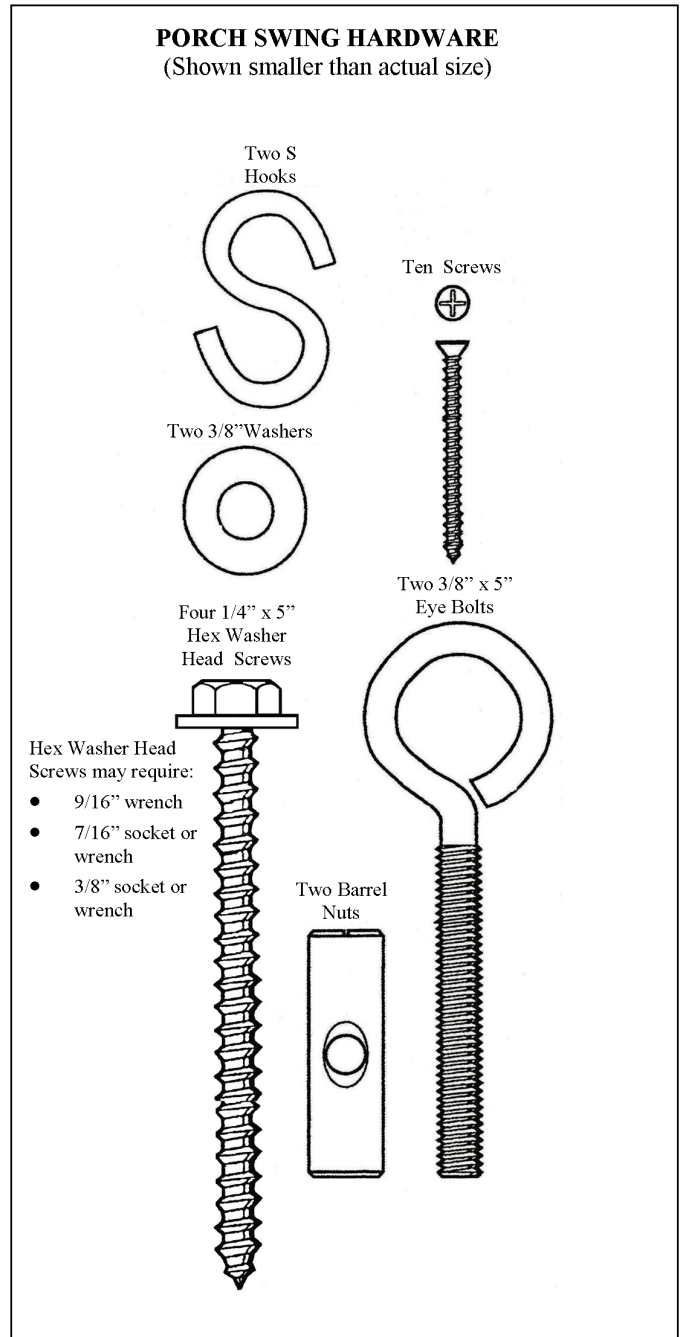

Please Note: After you have installed the seat ends onto the seat secure with (4) 2 1/2" screws. See figure right.

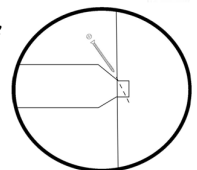

SEAT ASSEMBLY

STEP 2 Lay assembled seat on ground. Insert dowel end of uprights on assembled back into 1-1/4" holes on the back seat rail, adjusting uprights in or out as needed to align properly. Do not tap on seat back with hammer.

Tap uprights in or out until dowel drops into hole.

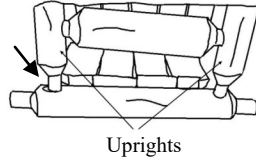

Uprights

To keep the seat rail from splitting, lay the back on the ground and drive the seat on by hitting the bottom of the seat assembly. As shown in Figure 1.

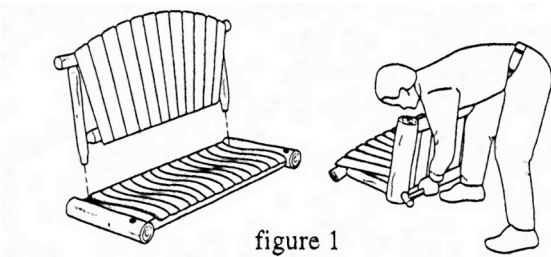

figure 1

STEP 3 Insert 12" arm support into 1-1/2" hole in arm, then into 1-1/2" hole in the top of the seat end. Drive dowels in as far as possible. Fasten arm to frame of the back by tightening the preinstalled 1/4" x 5" lag screw into the pilot hole in the arm with a wrench. Repeat process for the other arm. See Figure 2.

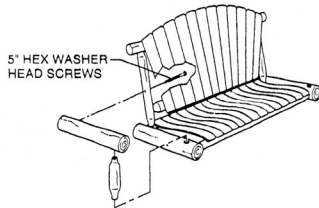

figure 2

STEP 4 Secure all dowel joints in place with screws perpendicular to the doweled end as shown below. Figure 3.

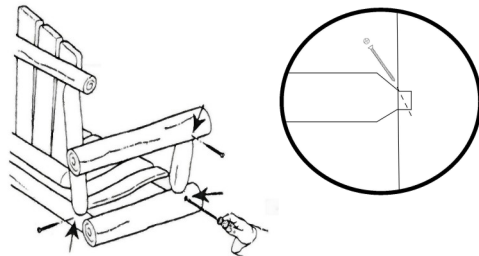

figure 3



Look for videos on: <https://www.youtube.com/watch?v=jg2BRgWMVpg&t=1s>

Lakeland Mills recommends:
WeatherSeal Premium Oil-Based Exterior Wood Stain & Sealant

www.ContinentalProd.com

STEP 5 Place barrel nut into horizontally drilled hole in end of swing arm. Position barrel nut with screwdriver, and screw in 5" eyebolt with 3/8" washer as shown. **TIGHTEN DOWN SECURELY!** Repeat process for other swing bar. See below. Figure 4.

figure 4

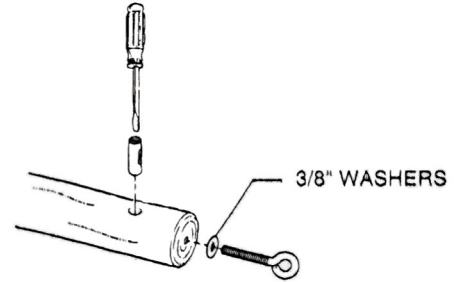

STEP 6 Fasten swing bars to side of unit as shown below. Measure 15" from the back of each arm and mark with pencil. (This gives a suggested pitch of the seat. You may change the pitch by altering the location of the lag screw in the arm.) With hammer, tap a 5" hex washer head screw through the bottom hole in swing bar and into pilot hole on seat end. Tap a 5" hex washer head screw through the upper hole in the swing bar and into the arm about 1/2" deep at the pencil marked position of the arm. Tighten down lag screws. Figure 5.

figure 5

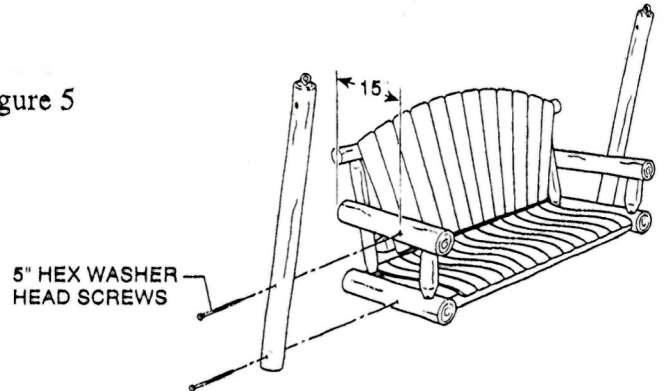

If you have hardware left over after completing your unit, it most likely has been assembled incorrectly, and may not be safe to use. Please call Customer Service at 800-427-5136 for assistance.

NOTE: Check all nuts and bolts for tightness before and during each usage season.

