



Please check contents **before assembly**. If any items are missing or damaged, **do not take the unit back to the store**. Call 1-800-427-5136 for customer service and we will save you time by correcting any problems directly for you.

TABLE COMPONENTS

4 Preassembled Leg Assemblies

1 Leg Brace Plate

8 Leg Braces

2 Pine Table Tops

NOTE: Cracks or Checks in logs are part of the natural beauty of cedar logs and should not be considered defects.

TOOLS AND HARDWARE
(Shown smaller than actual size)

16 - 2" Screws

14 - 1 3/4" Screws

4 - 2 1/2" Screws

8 - 1/4" x 4" Hex Washer Head Screws*

7/16" or 3/8" Socket

#2 Phillips Screwdriver

* Lag screw and washers may be substituted for Hex Washer Head Screws

Helpful Tips:

- Using a battery or electric power drill with a socket attachment will make assembly easier and faster.
- Use a good quality penetrating oil or wood deck sealer with a UV inhibitor and an anti-fungal.
- Umbrella hole is 1-5/8" diameter.

NOTE:

- **Read all instructions before starting.**

STEP 1 Lay the table tops upside down on a clean flat surface. Slide them tight together. Attach table top halves together with fourteen 1 3/4" screws in pre-drilled holes as shown in figure 1.

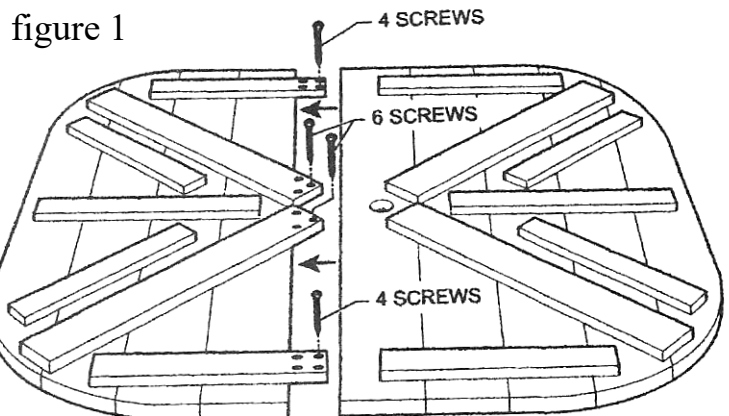

STEP 2 Place each leg assembly on top of the long cleats which run from the corner to the center of the table. Align the leg assemblies flush with the center end of the cleats. Attach with 4" Hex Washer Head Screws as shown in figure 2.

figure 2

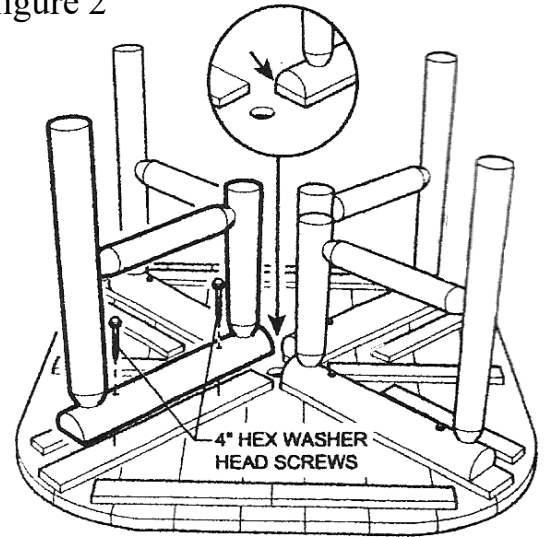

STEP 3 Center the leg brace plate on top of the leg assemblies. Attach with one 2 1/2" screw into each leg as shown in figure 3.

figure 3

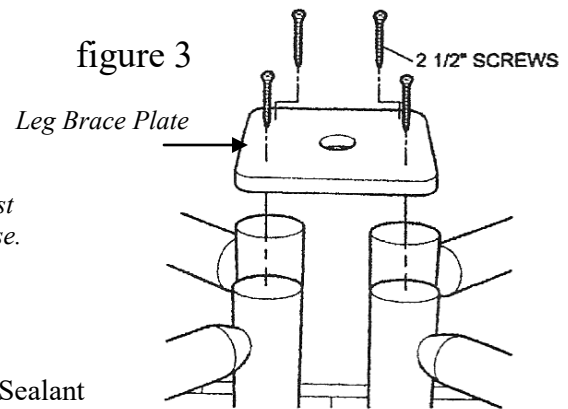

STEP 4 At the corners of the table attach two leg braces to the outside legs. Place against the leg and angle until it is over the table cleats. Attach securely with two 2" screws. Repeat for all the legs. As shown in figure 4.

figure 4

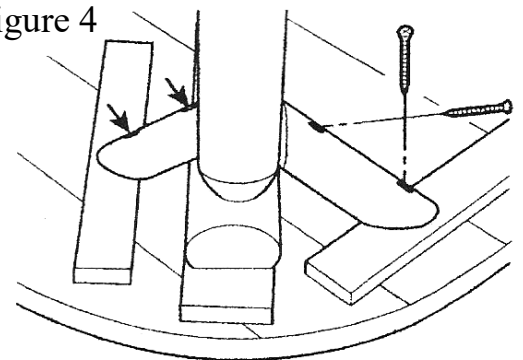

If you have hardware left over after completing your unit, it most likely has been assembled incorrectly, and may not be safe to use. Please call Customer Service at 800-427-5136 for assistance.

Lakeland Mills recommends:

WeatherSeal Premium Oil-Based Exterior Wood Stain & Sealant
www.ContinentalProd.com

Look for assembly videos on:



https://www.youtube.com/watch?v=kj_Rlu7J9_Y

Your table is now assembled and ready for finish or immediate use.

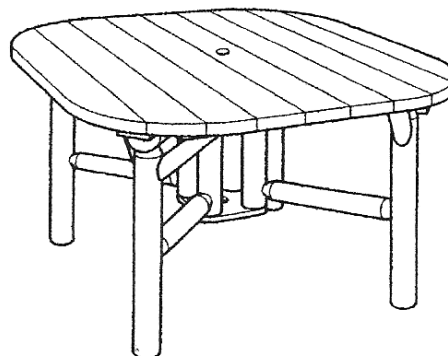

Check all joints for tightness before and during each usage season.

