



VANTAGE PRO<sup>®</sup> AND VANTAGE PRO PLUS<sup>™</sup>

# Fan-Aspirated ISS Retrofit Kit

Installation Instructions

Estimated Time Required: 60 Minutes

---

These instructions describe how to install the Vantage Pro<sup>®</sup> Fan-Aspirated Integrated Sensor Suite (ISS) Retrofit Kit.

This retrofit kit applies to all cabled and wireless versions of the fan-aspirated ISS.

## Components

The Fan-Aspirated ISS Retrofit Kit includes the following components:

- Externally-mounted SIM with housing
- Temperature/Humidity sensor module
- Rain Collector cable extension
- New SIM Power cable
- Splice kit to attach extension cables
- Mounting hardware for new SIM housing

## Tools for Setup

In addition to the kit, you will need the following tools:

- Small Phillips-head screwdriver
- Pliers or other crimping tool
- Other hand tools depending on your installation

---

**Tip:** *If your Wireless Fan-Aspirated ISS has been in service for over a year, this would be a good opportunity to replace the C-cell batteries used by the fan.*

---

## Installation Outline

Early version of the fan-aspirated ISS mounted the sensor interface module internally inside the radiation shield. Newer versions of the fan-aspirated ISS mount the SIM module in an external housing. The installation procedure for the two different versions are outlined separately below.

---

**CAUTION:** *Please work on your Vantage Pro ISS in a safe place. We strongly recommend that you remove the ISS from its installed position before beginning these steps.*

---

---

## **ISS With Internally Mounted SIM**

These are the procedures required to install the Fan-Aspirated ISS Retrofit Kit on an ISS that has the SIM mounted inside the radiation shield. More detailed directions are provided on the following pages.

1. Remove the ISS from its installed position.
2. Disconnect all cables from the old Sensor Interface Module (SIM) and remove the SIM from the radiation shield.
3. Mount the new Temp/Hum module.
4. Re-assemble the radiation shield.
5. Locate and cut the rain collector cable.
6. Splice on the rain collector cable extension.
7. Connect sensor cables to the new SIM.
8. Power the SIM.
9. Decommission the Old SIM (Wireless models only).
10. Test Communication between the ISS and the console.
11. Mount the ISS and the SIM Housing.
12. Return the old SIM to Davis.

## **ISS With Externally Mounted SIM**

These are the procedures required to install the Fan-Aspirated ISS Retrofit Kit in an ISS that has the SIM mounted in an external housing. More detailed directions are provided on the following pages.

1. Remove the ISS from its installed position.
2. Open the radiation shield.
3. Mount the new Temp/Hum module.
4. Re-assemble the radiation shield.
5. Disconnect all cables from the old SIM.
6. Connect sensor cables to the new SIM.
7. Power the SIM.
8. Decommission the Old SIM (Wireless models only).
9. Test Communication between the ISS and the console.
10. Mount the ISS and the SIM Housing.
11. Return the old SIM to Davis.

---

# Installation - ISS with Internal SIM

Use these procedures to install the retrofit kit on an ISS that has the SIM mounted inside the radiation shield.

---

**Note:** Use this procedure if your ISS has wing nuts on the bottom.

---

## Procedure 1. Remove the ISS from its Installed Position.

In order to take down your ISS you will first need to disconnect the anemometer cable. If you have a Cabled Vantage Pro station, you will also need to disconnect the console cable from the ISS.

---

**CAUTION:** Please work on your Vantage Pro ISS in a safe place.

---

1. At your Vantage Pro console, press and hold the DONE key and then press the “-” (down arrow) key to put the console in Setup Mode. This will prevent the reception of erroneous rain counts from the rain collector.
2. If you have mounted the anemometer remotely from the ISS or if you have a cabled ISS you will need to open the radiation shield. Remove the three wing nuts and separate the upper and lower sections of the radiation shield.

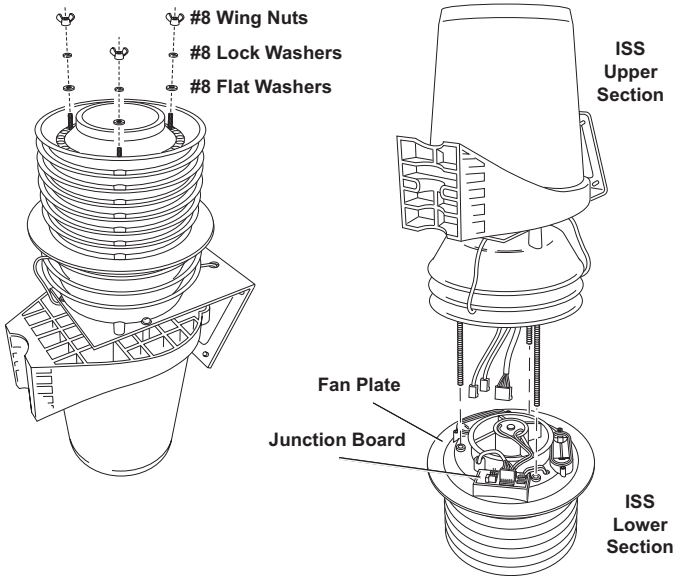

3. Locate the SIM inside the upper section of the radiation shield.

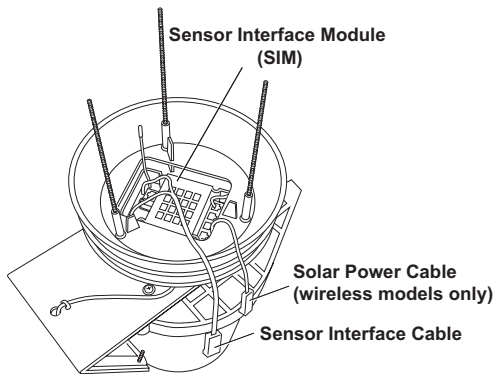

4. Disconnect the WIND sensor (anemometer) cable.
5. If you have a cabled station, you will also need to disconnect the Console cable from the SIM.
6. You can now remove the ISS from its mounted position. Move it to a safe place to install the kit components.

## Procedure 2. Disconnect all cables from the SIM and remove the SIM.

The Sensor Interface Module (SIM) consists of a PC board and cover. The SIM contains the ISS's sensor and communications electronics.

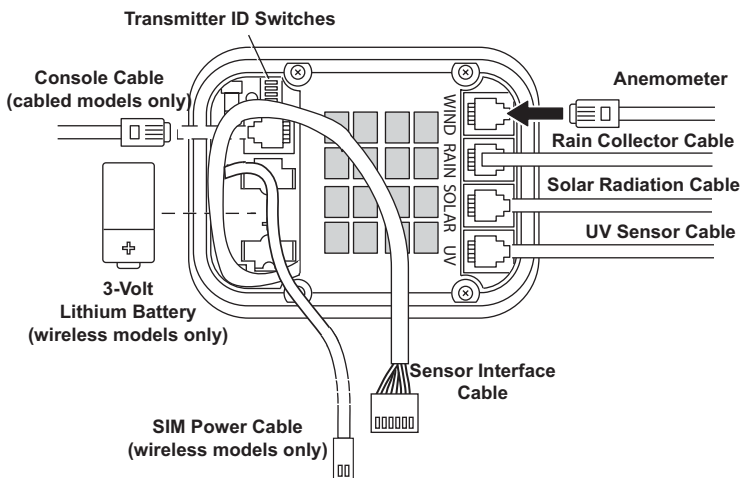

*Fan-Aspirated Radiation Shield SIM Cable Connections*

1. Unplug all cables from the SIM.

2. The SIM transmitter board, dust cover, and rear cover plate (not shown) are attached to the top radiation shield plate using 4 screws. Unfasten these screws and remove the dust cover along with the board and mounting plate.
3. Remove the SIM power cable, solar panel cable and the Sensor Interface Cable from the junction board located in the lower section of the radiation shield.

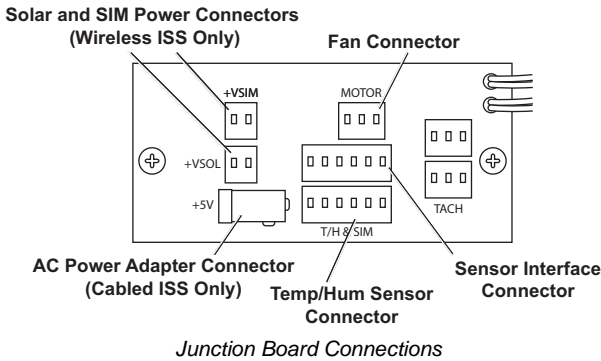

### Procedure 3. Mount the New Temp/Hum Module

1. Remove the fan and fan deflector from the lower section of the radiation shield.

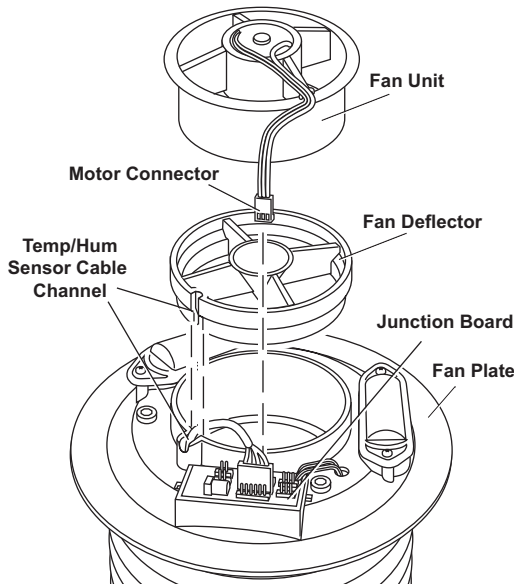

2. Remove the old Temp/Hum module from the radiation shield and unplug it from the junction board.

3. Install the new Temp/Hum module, being sure to set the sensor cable in the cable channel in the fan plate. The new Temp/Hum module cable will plug directly into the SIM instead of the junction board.
4. Reinstall the fan and fan deflector.
5. The new SIM power cable has a brown terminal at one end and a white terminal at the other end. Plug the brown terminal of the new SIM power cable into the junction board connector labeled +VSIM.



*Installing the Temp/Hum Sensor*

#### **Procedure 4. Re-assemble the radiation shield.**

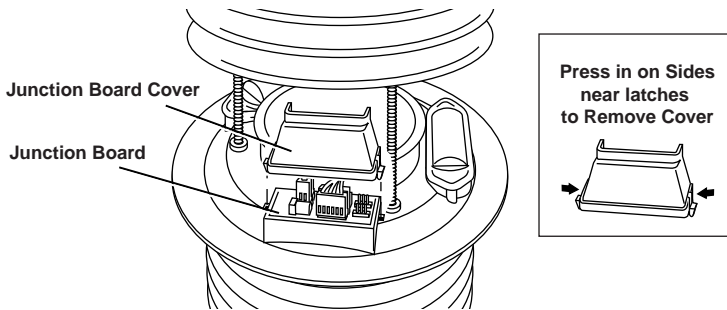

1. Line up the threaded rods on the upper section of the radiation shield with the mounting holes in the lower section.
2. Slide the two sections partially together, leaving enough clearance so you have access to the junction board.
3. Check the Junction Board connections: fan motor, SIM power and Solar (SOL) power (wireless models), AC-power adapter (cabled models).

- 
4. Install the Junction Board cover as shown above. The cover installs easily by pressing it into place.
  5. Slide the two sections of the Radiation Shield completely together.
  6. Fasten the two sections together using the 3 flat washers, lock washers, and wing nuts. The wing nuts should be finger-tight.

### **Procedure 5. Locate and cut the rain collector cable.**

These cables must be extended in order to reach the SIM housing.

1. Locate the rain collector cable hanging underneath the rain collector base. The rain collector cable is labeled "RAIN" near the modular connector.
2. Take the wire cutters and cut the rain collector cable next to the modular "phone-style" connector.

### **Procedure 6. Splice on the rain collector cable extension.**

For the best connection, note the following suggestions:

- Try to place the spliced connections in a location shielded from rain.
- When securing cables, place a cable clip or tie on each side of the connection point so the movement of the cables does not cause the connection to pull apart.
- Use the smaller splice connectors to extend the rain collector cable.

Follow this procedure to splice on the rain collector cable extension:

1. Use a wire stripper or a knife to strip away about 1½ inches (38 mm) of the jacket (the outer covering) of the cable.

Do not strip away any of the colored insulation on the individual wires. Repeat this procedure for the end of each cable you are connecting.

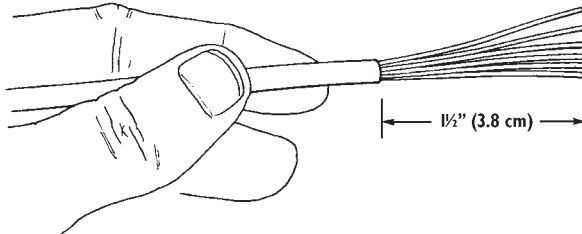

*Strip Shielding*

2. Take a wire from one of the cables and place it into one of the holes at the end of a splice connector.  
Make sure you push the wire all the way in. You can check this by looking through the clear side of the splice connector.

3. Take the same colored wire from the other cable and place it into the other hole at the end of the splice connector.
  - ◆ Make sure you push the wire all the way in. You can check this by looking through the clear side of the splice connector.

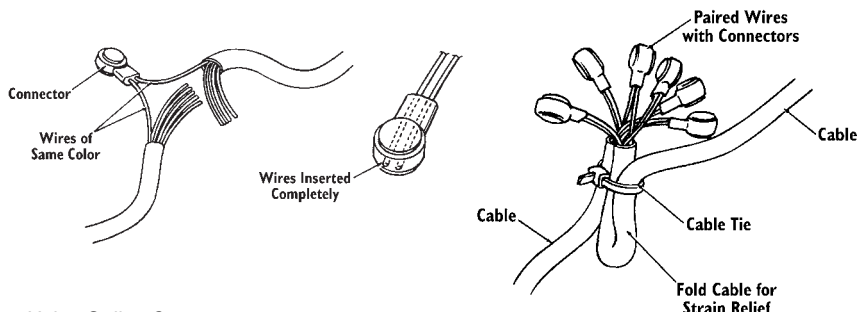

*Using Splice Connector*

4. Use pliers to snap the cap into place, securing the wires.
  - ◆ Use the provided yellow splice connectors.
5. Repeat this procedure for each pair of wires to be spliced.
6. Use a cable tie to secure the two cables together as shown.

Doing this provides a measure of strain relief which should prevent the wires from pulling apart under normal conditions. Cut off the excess cable tie when it is secure.
7. Gather the wires and splice connectors neatly together and secure with a cable tie in a protected location up close under the rain collector base.

## **Procedure 7. Connect Sensor Cables to the New SIM.**

The ISS sensors are connected by cables to the **Sensor Interface Module (SIM)**, located inside the new SIM housing. The SIM contains electronics that measure and store weather values for transmission to the console via cable or radio. The SIM housing protects the SIM from the elements and provides easy access to SIM cable connections.

1. Take one of the square rubber grommets from the bottom of the SIM housing and run the cables for the UV and Solar Radiation sensors through it, if included on your station.
2. **Wireless ISS:** Run the SIM Power cable through this first grommet.
3. Take the second square rubber grommet and run the Rain Collector, Anemometer, and Temp/Hum sensor cables through it.
4. **Cabled ISS:** run the console cable through this second grommet.
5. Install the first grommet in the left slot in the SIM housing, and install the second grommet in the right slot, adjusting the inside cable lengths as needed for a tidy installation.



- 
6. Refer to the ISS SIM Connections illustration and connect only the sensor cables as shown. You will connect the power cables in the next procedure.

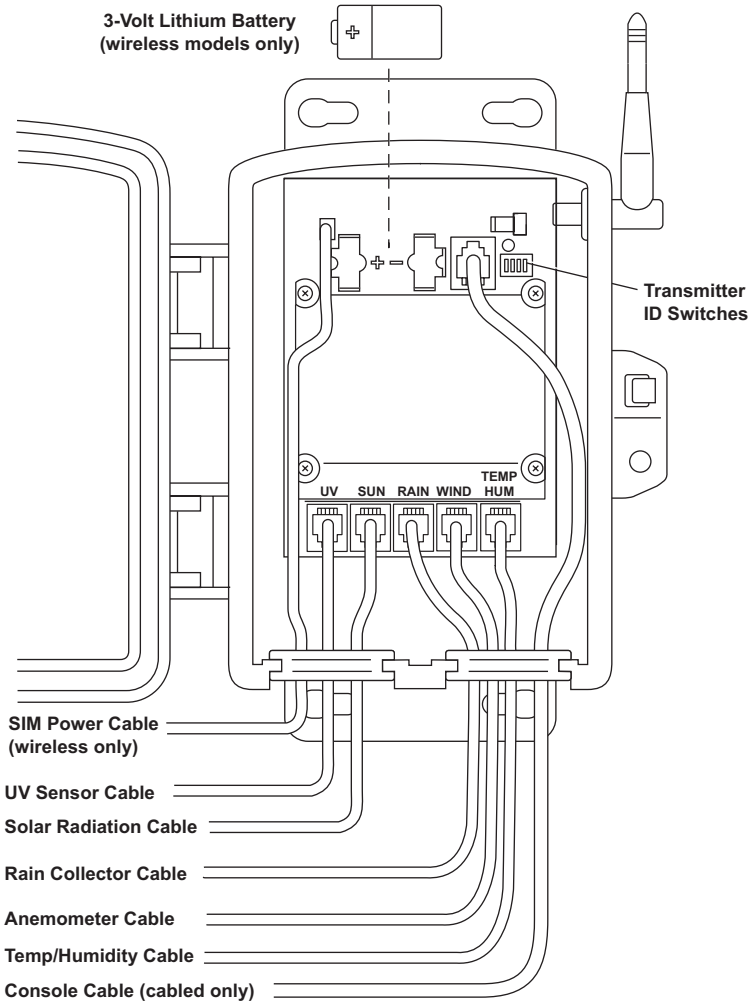

## Procedure 8. Power the SIM.

### Powering the Cabled ISS SIM

Cabled versions of the ISS receives power from the console via the 100' (30m) cable that runs between them.

- Plug the console cable into the SIM connector labeled “CONSOLE”.

---

## Powering the Wireless ISS SIM

Wireless versions of the ISS receive most of their power from the solar panel installed next to the rain collector. Backup power is provided by a 3-volt lithium battery.

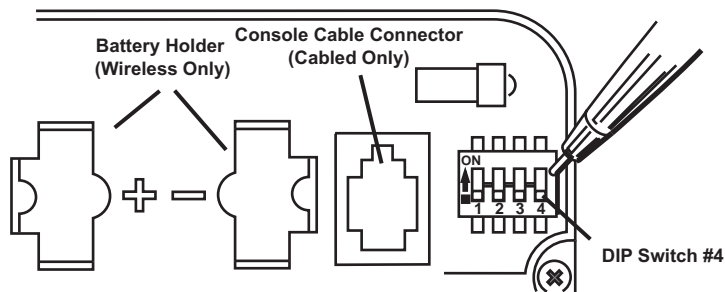

*DavisTalk Transmitter ID DIP Switch Settings*

1. Install the new battery in the SIM. The green test LED should blink once on power up.
2. Check that the DavisTalk transmitter DIP switches on the new transmitter board match those on the old board. Change the settings if necessary.
3. Connect the SIM power cable.

---

**Note:** *DIP switch #4 on the new transmitter board should be in the OFF position.*

---

## Procedure 9. Decommission the old SIM (Wireless ISS only)

Even after removing the battery, the old transmitter board will still have some power reserves and will continue to transmit data to your Vantage Pro console for up to 8 hours. In order to prevent the old transmitter board from sending erroneous data to your console, change the DavisTalk transmitter DIP switch setting on the **old** board.

1. Remove the battery from the old SIM.
1. Use a pen or other device with a fine point to change the setting of DIP switch # 1, #2, or #3. You only need to move one of these switches to change the ID setting.
2. As an added precaution, change the old transmitter board DIP switch #4 to the ON position. This will put the board in Test Mode, and more quickly discharge the board's power reserves. In Test Mode the green LED test light will flash approximately every 2.5 seconds.

## Procedure 10. Test Communication

Test your ISS to verify it is communicating with your Vantage Pro console by spinning the wind cups or turning the weather vane.

- If your console is in Setup Mode, you will need to exit Setup Mode to perform this test. Exit Setup Mode by pressing and holding the DONE key.
- The console should display these movements within a couple of seconds.

## Procedure 11. Mount the ISS and SIM Housing

Refer to the following illustrations and refer to this section in your ISS Installation Manual to mount the ISS and the new SIM Housing. If you removed the ISS from it's mounted position to install the Fan-Aspirated ISS Retrofit Kit, you can now re-mount it.

1. To prevent erroneous rain counts by your rain collector, put the console into Setup Mode before mounting it. Enter Setup Mode by pressing and holding the DONE key while you press the “-” (down arrow) key.
2. Install the ISS in it's former location.
3. Install the SIM housing adjacent to the ISS as shown in the illustrations.
4. When you have finished mounting the ISS, exit Setup Mode on the console by pressing and holding the DONE key.
5. Return the old transmitter board to Davis Instruments in the new board's shipping box. Use the included return shipping label.
6. **(Wireless Models only)** Please be sure the battery has been removed from the old board before shipping it.

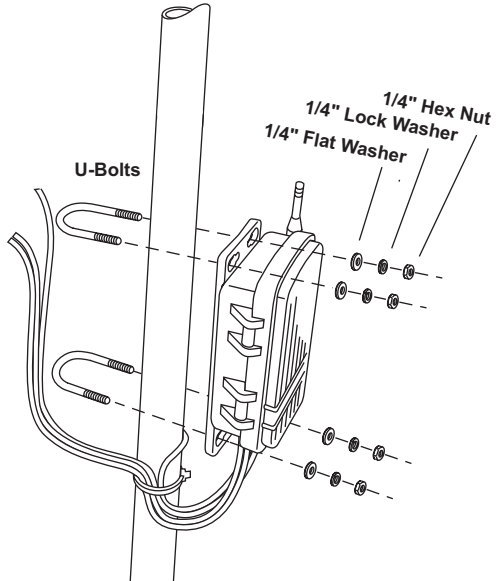
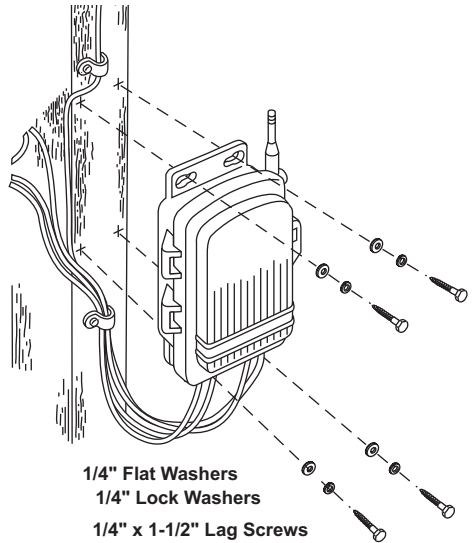

---

## Procedure 12. Return the Old SIM to Davis

1. Please return the old SIM and SIM housing (if you have one), in the Fan-Aspirated ISS Retrofit Kit shipping box.
2. Include the shipping paperwork you received with the Retrofit Kit.
3. Ship to:  
Davis Instruments  
Attn: Returns  
3465 Diablo Ave.  
Hayward, CA 94545

---

# Installation - ISS with External SIM

Use these steps to install the retrofit kit on an ISS that has the SIM mounted externally in the SIM housing.

---

**Note:** *Use this procedure if your ISS already has the SIM mounted in an external housing.*

---

## Procedure 1. Remove the ISS and SIM Housing from their Installed Position.

You need to move the ISS to a safe place where you can disassemble the radiation shield and replace the Temp/Hum sensor.

---

**CAUTION:** *Please work on your Vantage Pro ISS in a safe place.*

---

1. At your Vantage Pro console, press and hold the DONE key and then press the “-” (down arrow) key to put the console in Setup Mode. This will prevent the reception of erroneous rain counts from the rain collector.
2. Open the SIM housing and unplug the anemometer sensor cable, labeled WIND.
3. If you have a cabled station, unplug the console cable from the SIM.
4. Remove the ISS and the SIM housing. Move them to a safe work area.

## Procedure 2. Open the Radiation Shield

1. Remove the three screws connecting the rain collector base from the mounting bracket as shown below:
2. Lift the rain collector base off of the mounting bracket.

---

**Tip:** *For easier re-assembly, mark the holes in the mounting bracket used by the rain collector base, the holes used by the radiation shield, and the orientation of the bracket relative to the radiation shield.*

---

3. Remove the cardboard packing insert and discard.

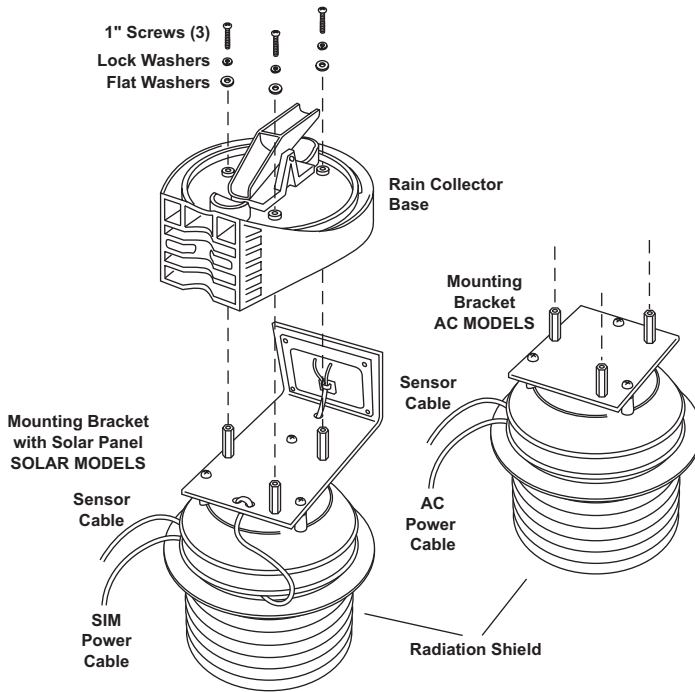

*Removing the Rain Collector Base*

4. Remove the three (3) screws connecting the mounting bracket to the radiation shield.
5. Lift the mounting bracket off of the radiation shield.

6. Remove the top two (2) radiation shield plates to expose the fan plate and junction board.

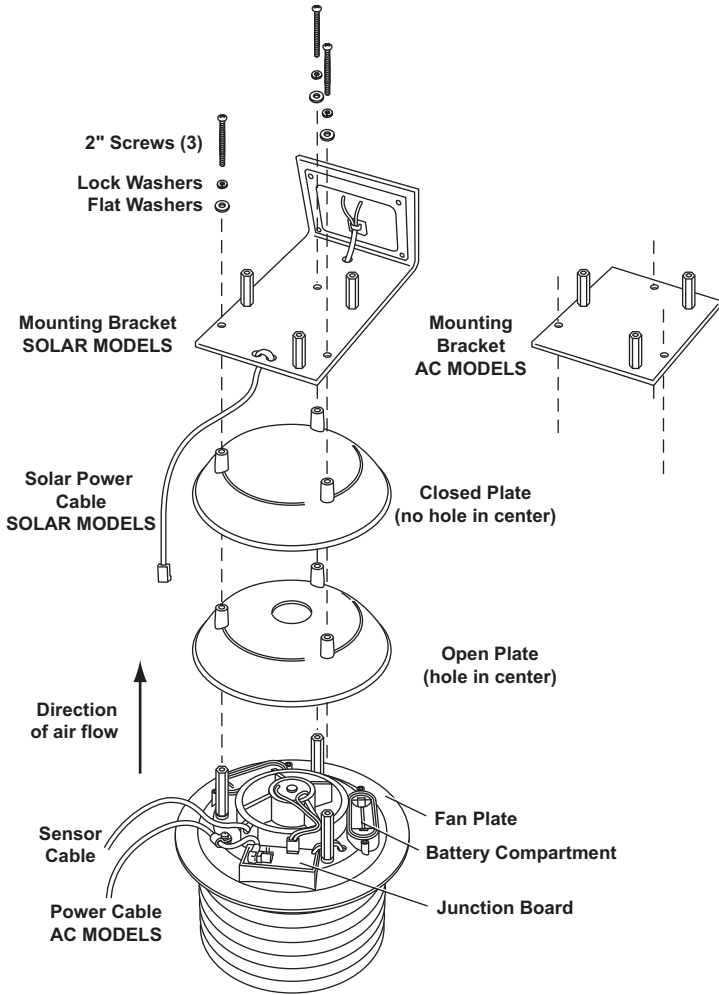

*Removing the Mounting Bracket*

---

### Procedure 3. Mount the new Temp/Hum module

1. Remove the Fan from the lower section of the radiation shield.

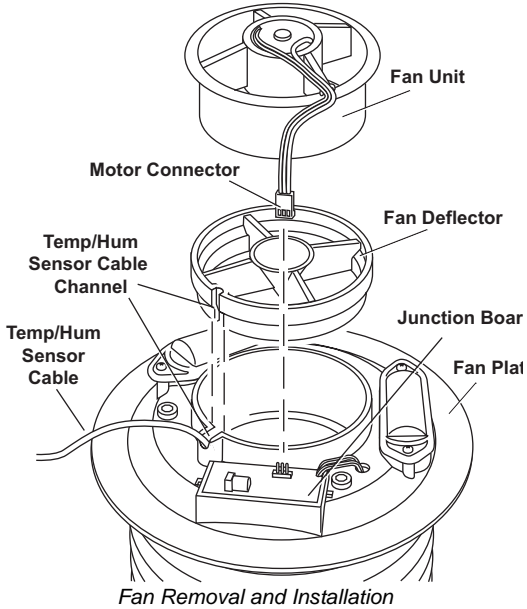

2. Remove the old Temp/Hum module from the radiation shield and replace with the new Temp/Hum module.



*Installing the Temp/Hum Module*

3. Reinstall the fan making sure the sensor cable is set into the cable channel.



---

## Procedure 4. Re-assemble the Radiation Shield

Refer to the disassembly drawings shown in Step 2 to re-assemble the Radiation Shield.

1. Make sure the Temp/Hum sensor cable runs through the cable channel molded into the fan plate.
2. Install the Junction Board Cover as shown in the illustration. The Junction Board Cover should press easily into the place.

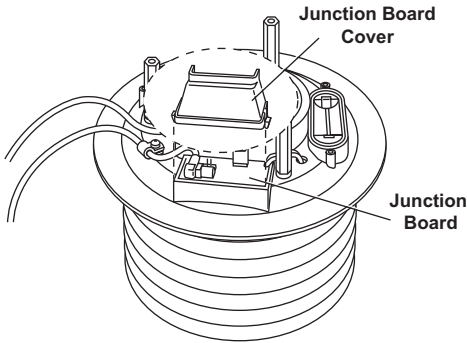

**Note:**  
Press in on Sides  
near latches to  
install or remove  
cover.

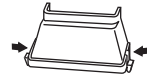

3. Place the two radiation shield plates on top of the fan plate, open plate first with the closed plate on top, being careful to line up the three screw holes.
4. Gently place the mounting bracket on top of the radiation shield, being careful to line up the three screw holes and also being very careful not to move the top two (2) radiation shield plates.

---

**Note:** *Solar ISS: Place the mounting bracket with the solar panel positioned opposite the location of the junction board.*

---

5. Hold the mounting bracket in place with one hand while you start the three (3) long screws.

---

**Tip:** *Be sure to start all three screws before you tighten any of them.*

---

6. Place the rain collector base on top of the mounting bracket and fasten using three screws. Do not over-tighten.
7. Install the rain collector cone on the base, making sure that nothing inside the cone interferes with the tipping bucket operation.

## Procedure 5. Disconnect all Cables from the Old SIM.

Open up your old SIM housing and disconnect all cables from the SIM.

---

## Procedure 6. Connect Sensor Cables to the New SIM.

The ISS sensors are connected by cables to the **Sensor Interface Module (SIM)**, located inside the new SIM housing. The SIM contains electronics that measure and store weather values for transmission to the console via cable or radio. The SIM housing protects the SIM from the elements and provides easy access to SIM cable connections.

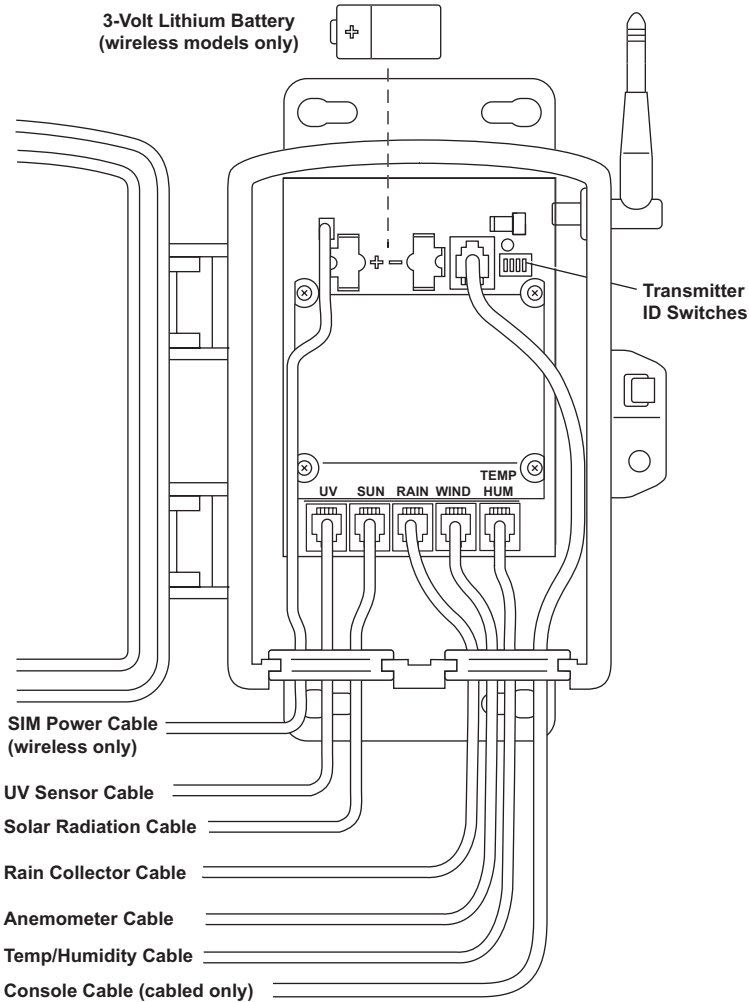

1. Take one of the square rubber grommets from the bottom of the SIM housing and run the cables for the UV and Solar Radiation sensors through it, if included on your station.
2. **Wireless ISS:** Run the SIM Power cable through this first grommet.
3. Take the second square rubber grommet and run the Rain Collector, Anemometer, and Temp/Hum sensor cables through it.

4. **Cabled ISS:** run the console cable through this second grommet.
5. Install the first grommet in the left slot in the SIM housing, and install the second grommet in the right slot, adjusting the inside cable lengths as needed for a tidy installation.
6. Refer to the ISS SIM Connections illustration and connect only the sensor cables as shown. You will connect the power cables in the next procedure.

## Procedure 7. Power the SIM

### Powering the Cabled ISS SIM

Cabled versions of the ISS receives power from the console via the 100' (30m) cable that runs between them.

- Plug the console cable into the SIM connector labeled “CONSOLE”.

### Powering the Wireless ISS SIM

Wireless versions of the ISS receive most of their power from the solar panel installed next to the rain collector. Backup power is provided by a 3-volt lithium battery.

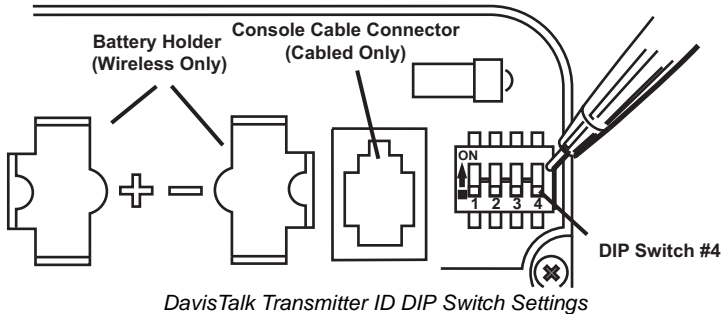

1. Install the new battery in the SIM. The green test LED should blink once on power up.
2. Check that the DavisTalk transmitter DIP switches on the new transmitter board match those on the old board. Change the settings if necessary.
3. Connect the SIM power cable.

---

**Note:** DIP switch #4 on the **new** transmitter board should be in the OFF position.

---

---

## Procedure 8. Decommission the Old SIM (Wireless ISS only)

Even after removing the battery, the old transmitter board will still have some power reserves and will continue to transmit data to your Vantage Pro console for up to 8 hours. In order to prevent the old transmitter board from sending erroneous data to your console, change the DavisTalk transmitter DIP switch setting on the **old** board.

1. Remove the battery from the old SIM.
1. Use a pen or other device with a fine point to change the setting of DIP switch # 1, #2, or #3. You only need to move one of these switches to change the ID setting.
2. As an added precaution, change the old transmitter board DIP switch #4 to the ON position. This will put the board in Test Mode, and more quickly discharge the board's power reserves. In Test Mode the green LED test light will flash approximately every 2.5 seconds.

## Procedure 9. Test Communication between the ISS and the console

Test your ISS to verify it is communicating with your Vantage Pro console by spinning the wind cups or turning the weather vane.

- If your console is in Setup Mode, you will need to exit Setup Mode to perform this test. Exit Setup Mode by pressing and holding the DONE key.
- The console should display these movements within a couple of seconds.

## Procedure 10. Mount the ISS and SIM Housing

Refer to the following illustrations and refer to this section in your ISS Installation Manual to mount the ISS and the new SIM Housing. If you removed the ISS from it's mounted position to install the Fan-Aspirated ISS Retrofit Kit, you can now re-mount it.

1. To prevent erroneous rain counts by your rain collector, put the console into Setup Mode before mounting it. Enter Setup Mode by pressing and holding the DONE key while you press the "-" (down arrow) key.
2. Install the ISS in it's former location.
3. Install the SIM housing adjacent to the ISS as shown in the illustrations.
4. When you have finished mounting the ISS, exit Setup Mode on the console by pressing and holding the DONE key.
5. Return the old transmitter board to Davis Instruments in the new board's shipping box. Use the included return shipping label.
6. **(Wireless Models only)** Please be sure the battery has been removed from the old board before shipping it.

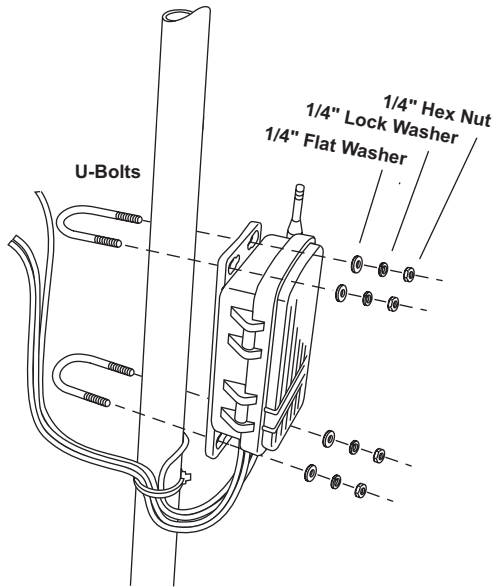
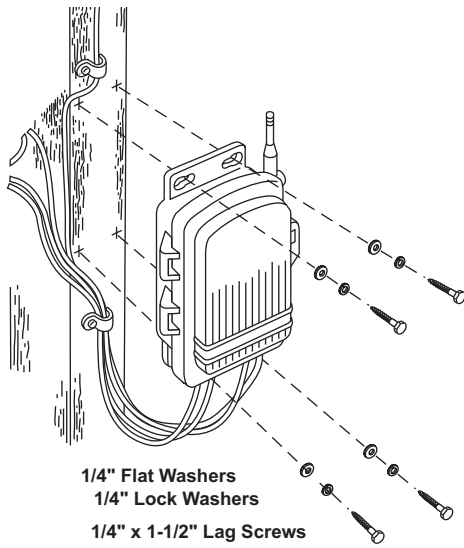

---

## Procedure 11. Return the Old SIM to Davis

1. Please return the old SIM and SIM housing (if you have one), in the Fan-Aspirated ISS Retrofit Kit shipping box.
2. Include the shipping paperwork you received with the Retrofit Kit.
3. Ship to:  
Davis Instruments  
Attn: Returns  
3465 Diablo Ave.  
Hayward, CA 94545

## Troubleshooting

Please contact Davis Technical Support if you have any questions or if you encounter problems installing the Fan-Aspirated ISS Retrofit Kit Retrofit Kit.

### Contacting Davis Instruments

**(510) 732-7814** for Technical Support, Monday – Friday, 7:00 a.m. – 5:30 p.m. Pacific Time.

**(510) 670-0589** Fax to Customer Service or Tech Support.

**www.davisnet.com** Copies of User Manuals are available on the “Support” page. Watch for FAQs and other updates. Subscribe to Davis’ e-newsletter. **support@davisnet.com** E-mail to Technical Support.



---

### **FCC Part 15 Class B Registration Warning**

This equipment has been tested and found to comply with the limits for a class B digital device, pursuant to Part 15 of the FCC Rules. These limits are designed to provide reasonable protection against harmful interference in a residential installation. This equipment generates, uses and can radiate radio frequency energy and, if not installed and used in accordance with the instructions, may cause harmful interference to radio communications. However, there is no guarantee that interference will not occur in a particular installation.

If this equipment does cause harmful interference to radio or television reception, which can be determined by turning the equipment off and on, the user is encouraged to try to correct the interference by one or more of the following measures:

- Reorient or relocate the receiving antenna.
- Increase the separation between the equipment and receiver.
- Connect the equipment into an outlet on a circuit different from that to which the receiver is connected.
- Consult the dealer or an experienced radio/TV technician for help.

Changes or modifications not expressly approved in writing by Davis Instruments may void the user's authority to operate this equipment.

---

Product Numbers: 6921, 6921C

Davis Instruments Part Number: 7395.132  
Fan-Aspirated ISS Retrofit Kit  
Rev. B (April 16, 2003)

This product complies with the essential protection requirements of the EC EMC Directive 89/336/EC.  
Copyright ©2003 Davis Instruments Corp. All rights reserved.

Vantage Pro is a registered trademark of Davis Instruments Corporation.



3465 Diablo Avenue, Hayward, CA 94545-2778 U.S.A.  
510-732-9229 • Fax: 510-732-9188  
E-mail: [info@davisnet.com](mailto:info@davisnet.com) • [www.davisnet.com](http://www.davisnet.com)