

DAVIS 

#420
Cable Buddy,
one lube nut



(#421, Cable Buddy
with two lube nuts,
discontinued 2012)

STEERING CABLE LUBRICATION SYSTEM

INSTRUCTIONS—English

CABLE BUDDY™ makes steering easier and safer on boats with inboard, outboard, or inboard/outboard steering cables. Prevents corrosion and freezing, lubricates otherwise inaccessible inner cable. Seals the critical area of the steering cable from moisture intrusion while allowing delivery of proper oil to the cable. **7/8" x 14 threads** fit Johnson/Evinrude and all Japanese outboard motors.

Three parts of the Cable Buddy system:

- **Cable Buddy™** lube nut, made of marine grade stainless steel, comes with sealing washer and plug. **Cable Buddy II** (#421), with two lube nuts, is designed for the twin cable steering systems used on some high performance boats.
- Oiling tube assembly.
- Max-Lube™, the ideal lubricant for steering cables. Max-Lube has high water separation properties and affords corrosion protection in extreme conditions. Maintains flow at temperatures as low as -40°F (-40°C).

Installing Cable Buddy now saves the hassles and expense of buying a new cable later.

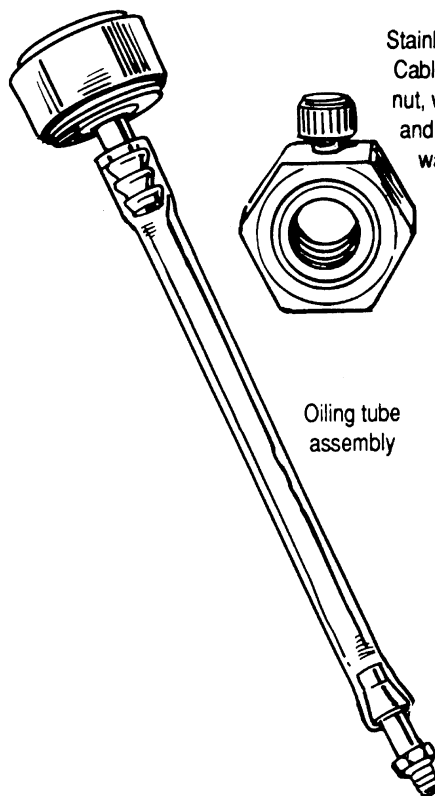
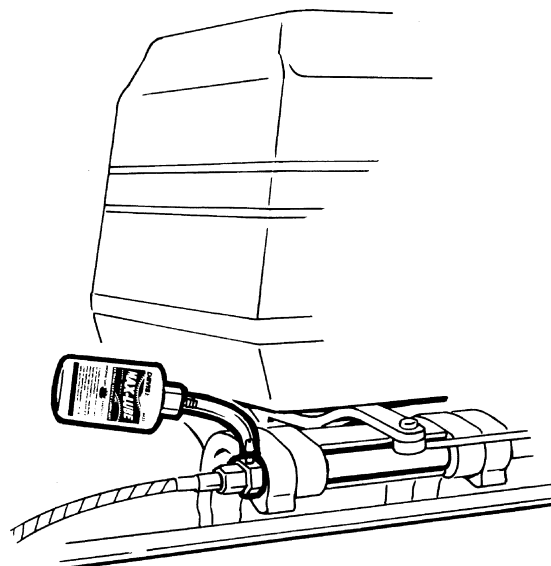

Stainless steel
Cable Buddy
nut, with plug
and sealing
washer

Oiling tube
assembly

Max-Lube:
the ideal
lubricant for
steering
cables.

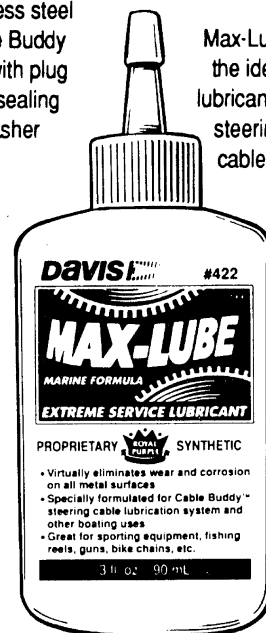

INSTALLING CABLE BUDDY

Note: Regular Cable Buddy (#420) shown. Cable Buddy II (#421) allows installation of Cable Buddy nuts on boats with twin steering cables.

1. Remove linkage nut, disconnect steering arm from steering rod.
2. Remove coupler nut, slide steering cable out of tilt tube. Note: some late model, low profile boats require complete rotation of the motor on its mounts in order to remove the cable.
3. Thoroughly clean the steering rod/cable and tilt tube.

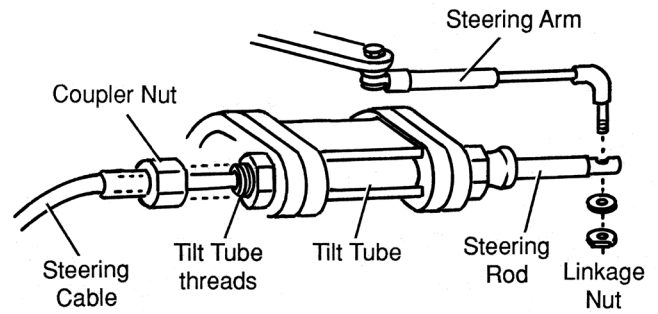

4. Remove tilt tube nut from tilt tube.

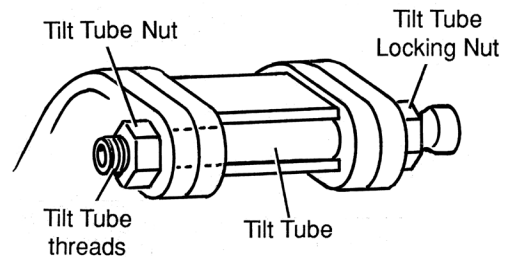

5. Remove nylon plug from Cable Buddy nut and set it aside. Thread Cable Buddy nut onto the tilt tube. Tighten with light pressure. The hole in the side of Cable Buddy should be turned so it is easily accessible for drilling and oiling. You should have at least 1/2" (13 mm) of threads exposed on the tilt tube after Cable Buddy is in place. If not, back off the tilt tube locking nut (at other end of tilt tube) to allow tube to shift toward coupler end.

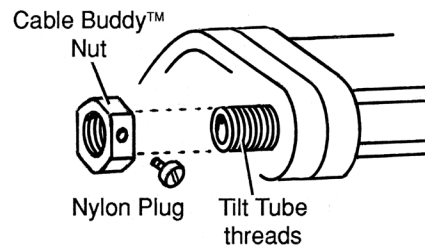

6. Place a drill bit of approximately 1/8" (3 mm) diameter through the Cable Buddy plug hole. Drill through the tilt tube. Remove any shavings.

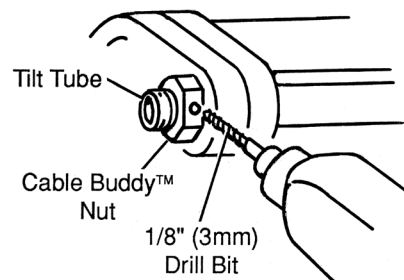

7. Place Cable Buddy's flat nylon washer inside the coupler nut over the end of the steering cable. Reassemble cable and steering coupling. Screw in Cable Buddy's nylon plug.

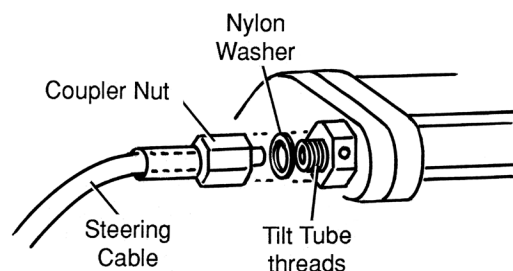

OILING THE CABLE

Remove Cable Buddy's nylon plug. Screw the oiling tube assembly into the plug hole. Firmly screw the other end of the oil tube assembly to the oil bottle. Turn bottle upside down and squeeze firmly while the steering wheel (or motor) is slowly turned at least three times to the full extent right and left. This should consume at least half of the oil in the full bottle. If not, repeat until half the oil is delivered. Reinstall nylon plug. Some oil leakage is normal at this point. Under most circumstances the oil coating should now extend down the first 18" (56 cm) or so of the inner cable. Oiling should be repeated once or twice annually, depending on the environment in which the motor is used.

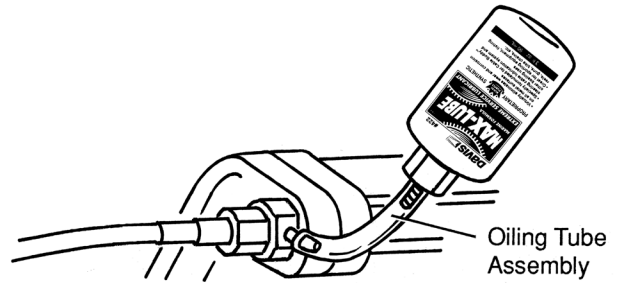

Use with
LUBE II™
Steering Rod
Lubricator (#425)
for *complete*
steering system
protection!

IT'S EASY TO PREVENT STEERING PROBLEMS!
KEEP WATER & DIRT OUT... ... PUT LUBRICANT IN!

THE ONLY PRODUCT THAT LUBRICATES STEERING CABLE
CABLE BUDDY™
#420

INBOARD OR OUTBOARD MOTORS

SEALS AND LUBRICATES STEERING ROD
LUBE II™
#425



Davis Instruments

3465 Diablo Ave., Hayward, CA 94545 U.S.A.
Phone (510) 732-9229 • Fax (510) 732-9188
info@davisinstruments.com

www.davisinstruments.com