

Wheel-a-Weigh™

LAUNCHING WHEELS

ENGLISH
See separate document for French instructions

This product is not designed to be used on loads over 330 lbs. (150 kg).

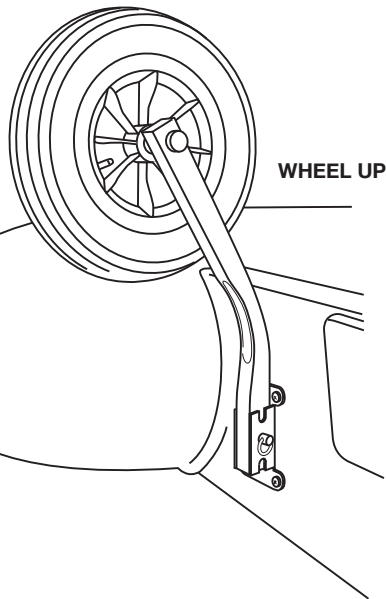
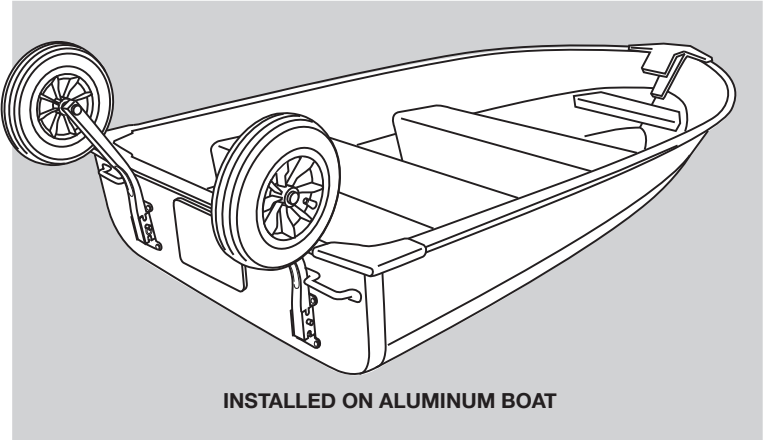
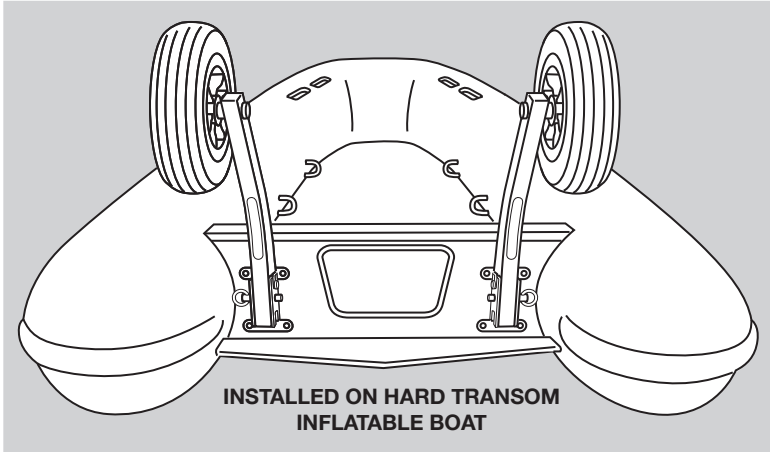

CARRYING THE BOAT

Wheel-a-Weigh transom wheels are portable and removable. A detent pin on each pivot bracket lets you position the wheels up or down, or remove them completely for storage.

WHEEL DOWN

WHEEL REMOVED

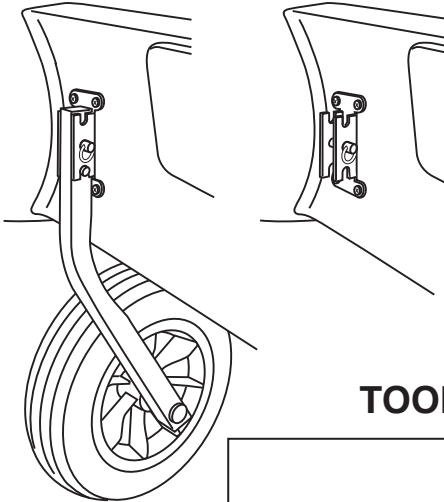

In most cases, you can operate the craft without removing the wheels.

CAUTION: This product is not designed to be towed behind a vehicle. Damage may occur and will void the warranty.

Extra Duty has curved wheel frames, allowing wheels to pivot under the boat, moving the balance point forward to make moving heavier loads easier.

TOOLS NEEDED FOR INSTALLATION

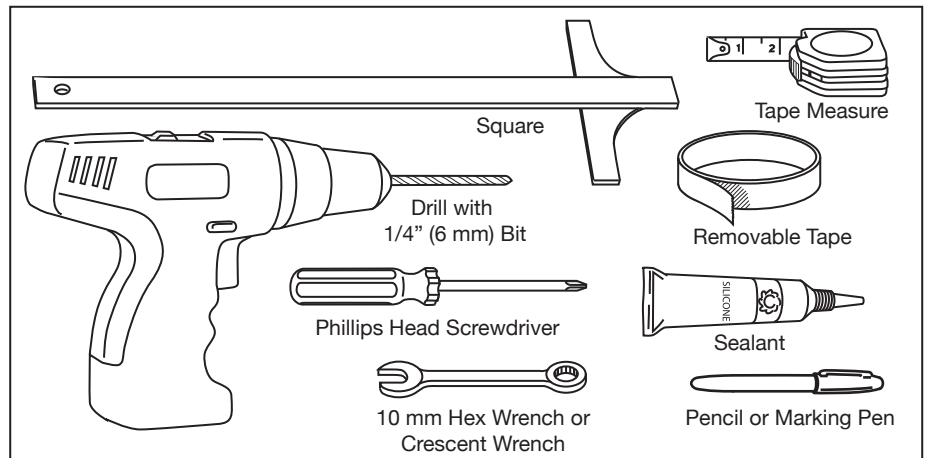

#1483 PARTS LIST

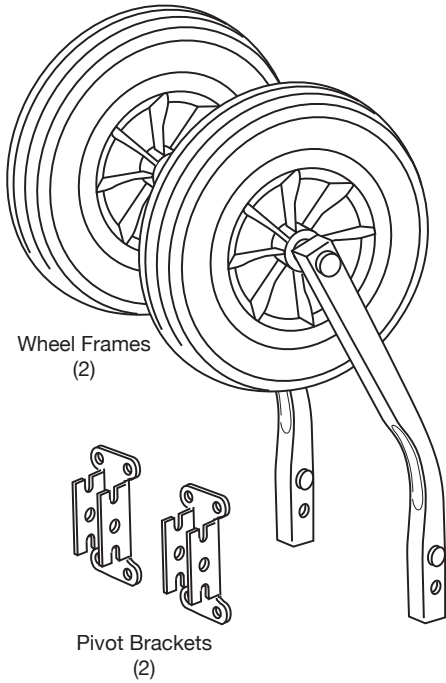

Wheel Frames
(2)

Pivot Brackets
(2)

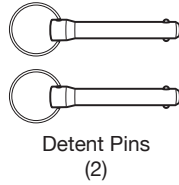

Detent Pins
(2)

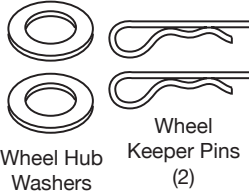

Wheel Hub Washers
(2)

Wheel Keeper Pins
(2)

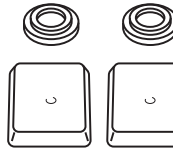

Spare Frame Caps
(4)

HARDWARE

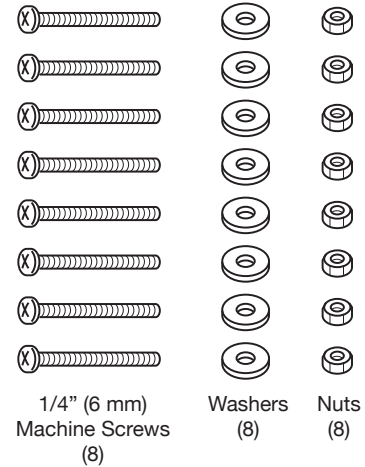

ASSEMBLY INSTRUCTIONS

The process below will be repeated for both port and starboard wheels. Quality of installation depends on careful measurements—"measure twice, drill once."

- 1. POSITION WHEELS ON THE TRANSOM.** Be sure they clear obstructions such as lifting handles on an aluminum boat or tubes of an inflatable. Leave clearance for outboard motors. Position the wheels as far apart of possible, with the tires facing out. Mark the horizontal location.

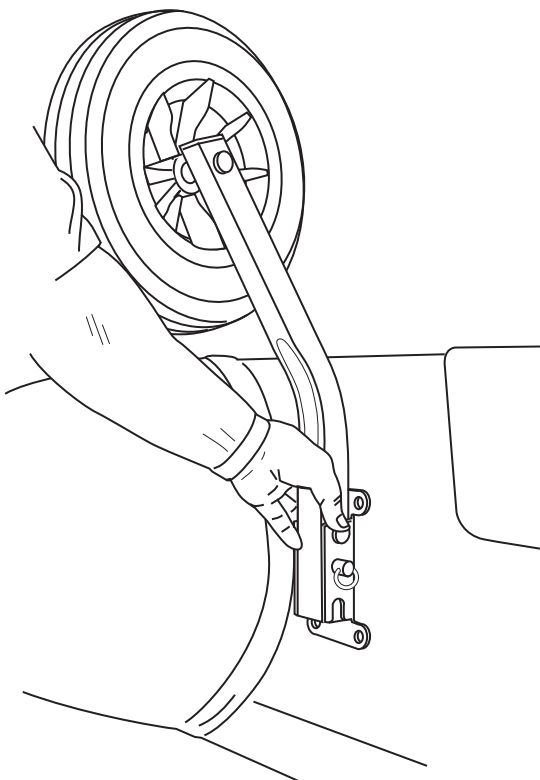

- 2. ALLOW NO MORE THAN 3 1/2" (9 cm) BELOW THE PIVOT BRACKET** for the wheels to clear the bottom of the transom. Measure and mark this vertical location.

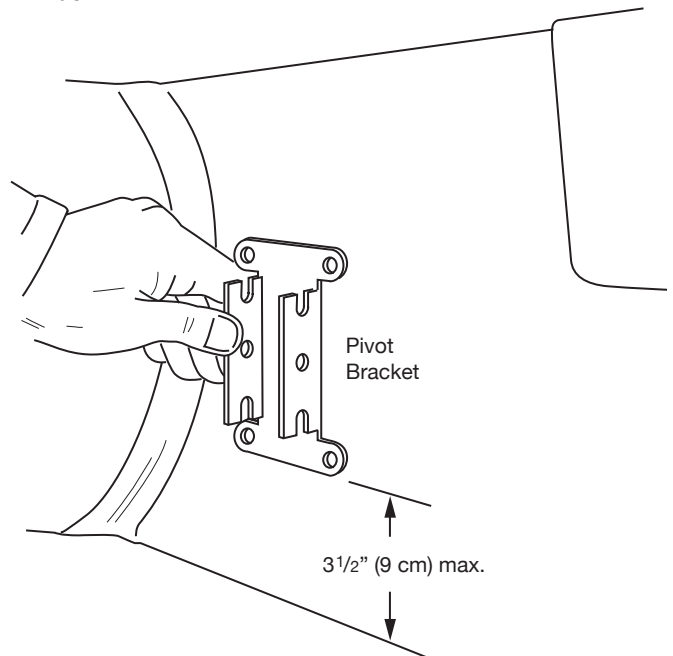

- 3. MARK TRUE VERTICAL.** Most applications call for perpendicular orientation of the wheel frames. This can be determined using a T-square.

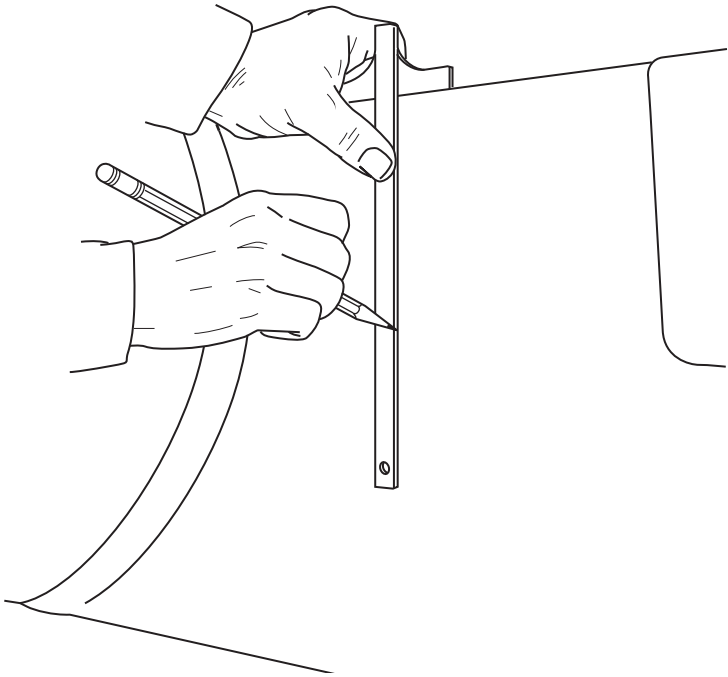

- 4. DOUBLE-CHECK THE 3 1/2" (9 cm).** Confirm that this distance is not exceeded between the pivot bracket and the bottom of the transom.

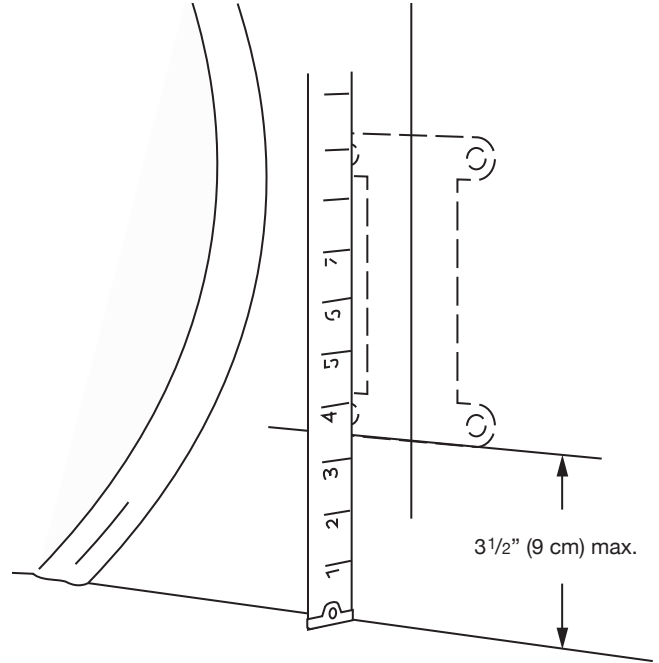

- 5. TAPE PIVOT BRACKET IN PLACE** with removable tape.

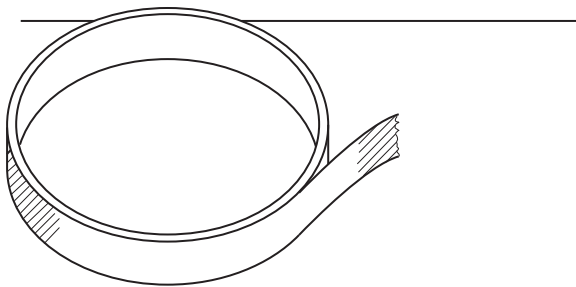
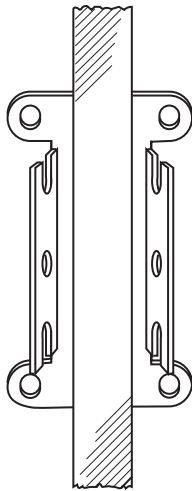

- 6. MARK FOUR HOLES** for drilling.

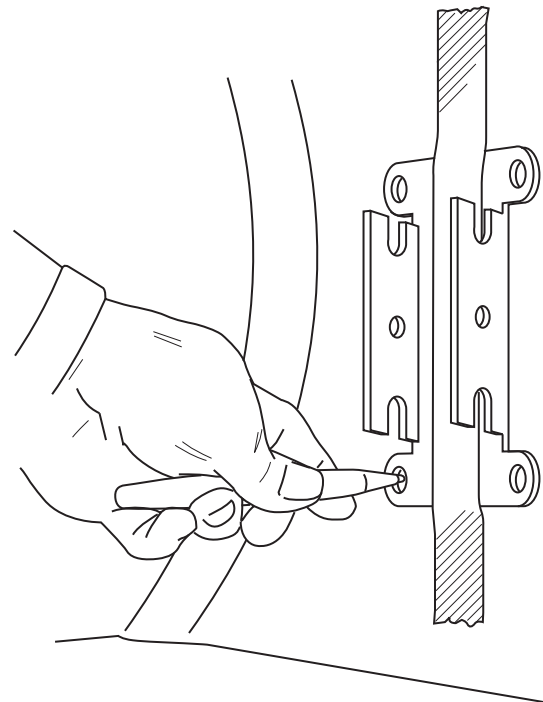

7. DRILL FOUR 1/4" (6 mm) HOLES through the transom for attaching the pivot bracket.

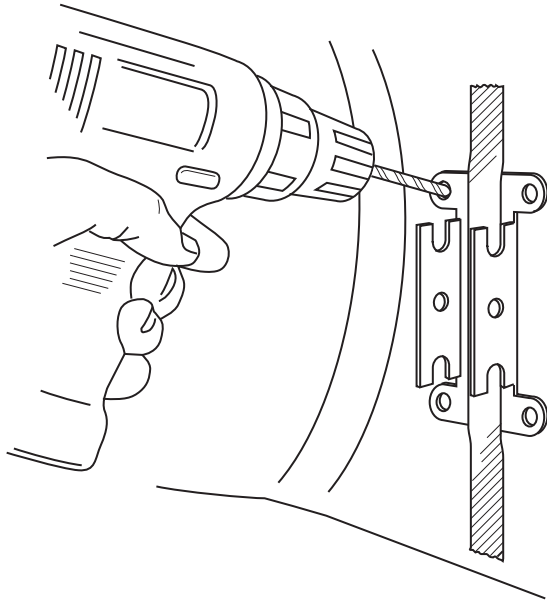

8. AFFIX PIVOT BRACKET. 1/4" (6 mm) machine screws, washers and hex nuts are provided in the parts kit. Apply sealant behind the pivot bracket. Assemble parts as shown below, then tighten the machine screws until snug.

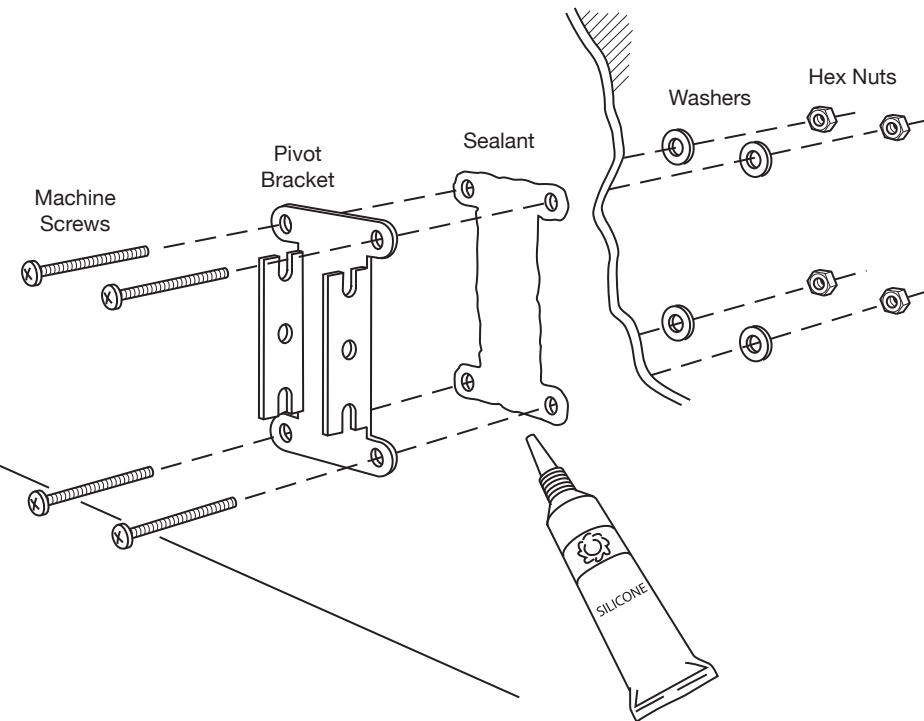

9. ATTACH WHEELS. With both pivot brackets installed, the wheel frames can now be fastened with the detent pins.

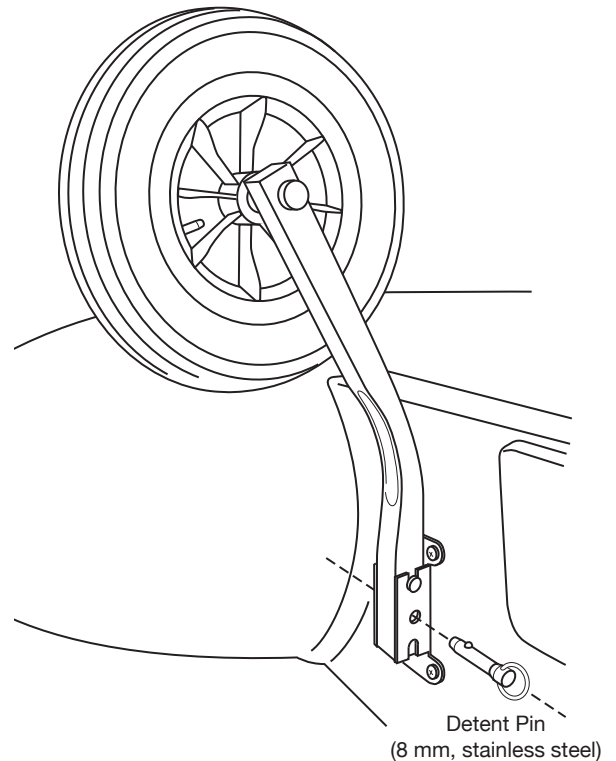

ONE-YEAR WARRANTY

We warrant our products to be free of defects in material and workmanship for one year from the date of original purchase. Write for full warranty details.

This warranty does not apply to product which has been used on loads weighing more than 330 pounds (150 kg).

Davis Instruments

3465 Diablo Ave., Hayward, CA 94545 U.S.A.

Phone (510) 732-9229 • Fax (510) 732-9188

info@davisinstruments.com

www.davisinstruments.com