

CATAMARAN WIND INDICATOR INSTRUCTIONS

Telo-Cat™ indicates exactly where the wind is, so you sail at maximum speed on all points of sail.

- Rugged construction
- Versatile reference arm system for tacking upwind or downwind
- Highly visible vane

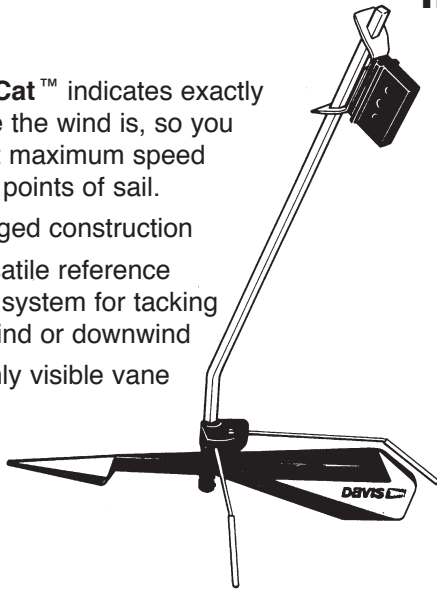

Telo-Cat fits all popular catamarans

- Hobie 14, 16
- Supercat 15, 17
- Prindle models with turnbuckle forestay adjuster
- NACRA 5.2

Telo-Cat will also fit other catamarans using forestay fittings similar to models above.

HOW TO ASSEMBLE

1. Attach reference arms as shown:

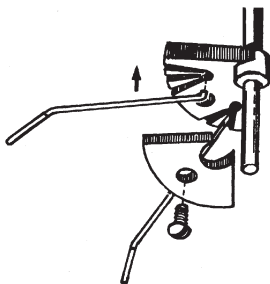

2. Slide vane onto shaft, add nylon washer. Captivate with collar. Secure collar on shaft with #4 set screw.

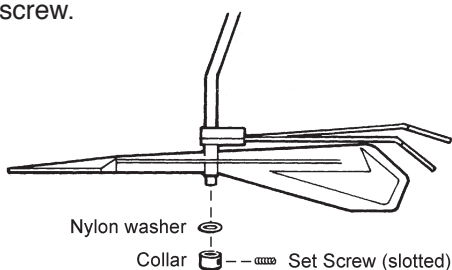

HOW TO MOUNT

Typical installations for most catamarans are shown below. All mounting hardware is included.

Hobie 14, 16

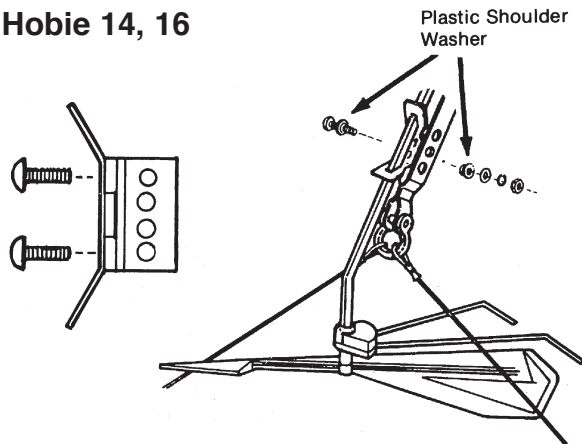

Prindle

All models with turnbuckle type forestay adjuster.

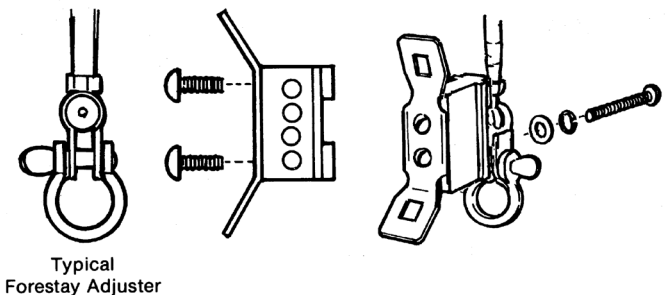

NACRA 5.2 Mounting

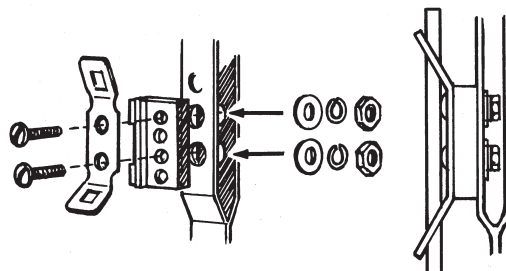

Continued...

IMPORTANT: Install split ring in hole on shaft after it has been positioned in the spring clip. The split ring prevents the shaft from falling into the water if it should vibrate loose.

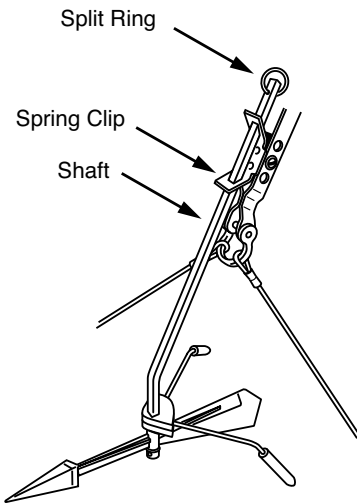

HOW TO ADJUST

- 1. Balance.** The Telo-Cat is factory balanced and needs no further adjustment.
- 2. Shaft Angle.** Shaft should be 90° to water level.

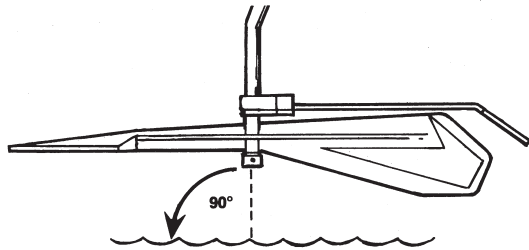

If angle for your catamaran is not correct, carefully clamp in a vice and bend as shown:

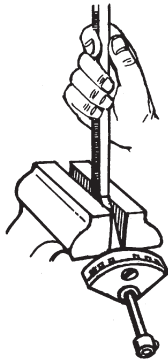

3. Reference Arm Angle. Adjustable reference arms allow you to determine the apparent wind angle.

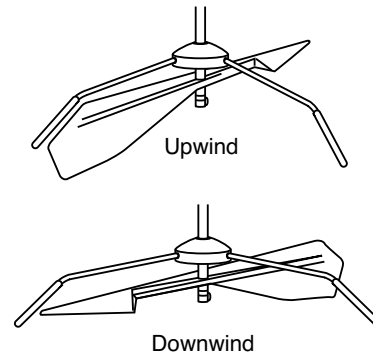

Three different detent positions are provided: 60°, 90°, and 120°. The 90° position is a good angle to use for general purpose sailing. The following guidelines may allow you to set the angle more precisely:

- Upwind tacking in light winds: 75°–90°
- Upwind tacking in medium to heavy winds: 60°–75°
- Downwind tacking: Determine the best angle for your situation through sailing trials and adjust the Telo-Cat accordingly. Proper apparent wind angle is very dependent on windspeed, boat speed, and tacking angle.

To adjust between or beyond the stock angles, carefully bend with pliers as shown:

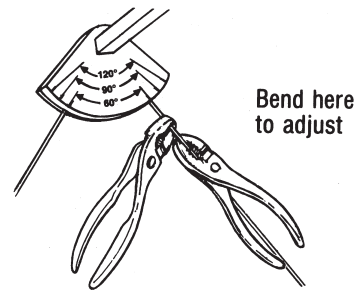

Continued...

MAINTENANCE

Telo-Cat is easily removed for trailering. No tools required.

Made of high impact plastic and stainless steel, the Telo-Cat is highly corrosion resistant. Occasionally salt or other foreign materials may build up between the shaft and the hub of the vane, causing the vane to act sluggish. To correct, remove collar and vane and flush thoroughly with fresh water. No other lubrication is needed or recommended.

IMPORTANT: Check for adequate spring tension on the spring clip each time you install the removable shaft. The Telo-Cat spring clip is made of the finest stainless steel, hardened to provide a secure grip over the shaft. Some spring clips may, however, loosen their grip over time. If the shaft does not slip when pulled hard, there is adequate tension. If it does slip, the spring can easily be retensioned:

1. Remove the Telo-Cat shaft from the spring clip.
2. Carefully bend the clip a little at a time, as shown, until it positively grips the shaft.

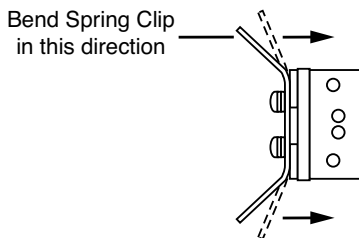

Remember to install the split ring in the hole on the shaft after it has been positioned in the spring clip.

Indexing shaft position on the clip. You will note that a groove has been cut in the shaft to keep it from falling out even if the spring clip should lose its grip. This groove serves as a safety stop near the top of the shaft yet allows the shaft to be adjusted to any height. Once the correct height is known for your particular boat, a similar groove can be filed or cut to positively hold the shaft at the desired height.

REPLACEMENT PARTS

1452 Extra Vane, 8" length (20 cm)

Davis Instruments

3465 Diablo Ave., Hayward, CA 94545 U.S.A.

Phone (510) 732-9229 • Fax (510) 732-9188

info@davisinstruments.com

www.davisinstruments.com