

# Rain Collector (#6466 & 6466M)

This rain collector can be used with Vantage Pro2™ weather stations, including Vantage Pro2, Vantage Pro2 Plus, and the Sensor Transmitter, as well as an EnviroMonitor Node.

The following instructions assume the rain collector is being used with a Vantage Pro2 or Vantage Pro2 Plus Integrated Sensor Suite (sensor suite).

Refer to the user manual that came with your station for more information.

*Manuals are available at [www.davisinstruments.com](http://www.davisinstruments.com).*

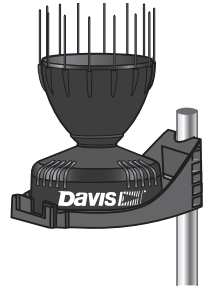

Note: Model number 6466 is factory-calibrated to take rain measurements in 0.01 inches. The metric version of the rain collector, number 6466M, comes factory-calibrated to take measurements in 0.2 mm.

## Components

- Rain collector cone latched onto base
- Base with tipping mechanism and 40' (12 m) cable
- U-bolt, backing plate and 2 each: lag screws, flat washers, lock washers, hex nuts, and cable tie
- Debris Screen
- 16 3.5" (9 cm) bird spikes (optional)

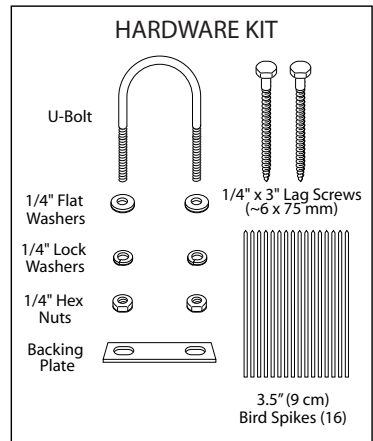
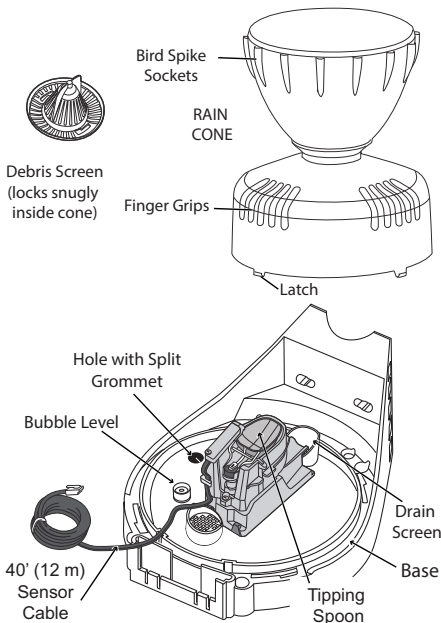

---

## Tools and Materials Needed

You may need some of the following tools and materials to install the rain collector.

- Wire cutter
- Drill with 3/16" (5 mm) drill bit
- Medium Phillips screwdriver
- Adjustable wrench (or 3/16"/5 mm) for flat surface mounting, 7/16"/11 mm for pole mounting)
- Cable clips or weather-resistant cable ties with screw holes or other means for mounting
- Small hammer

## Prepare the Rain Collector

---

**Tip:** *The rain collector is shipped with the 40' (12 m) cable coiled and exiting through a slot in the rain collector base. You may want to uncoil the cable and feed it down through the hole with a grommet installed in the base behind the tipping spoon.*

---

1. Remove the cone from the base by rotating the base until the latches on the cone line up with the latch openings in the base, then lifting the cone away from the base.

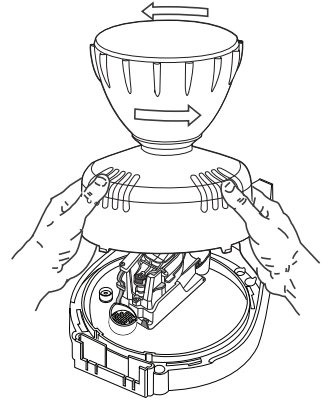

2. Carefully cut and remove the plastic tie which holds the tipping spoon in place during shipping.

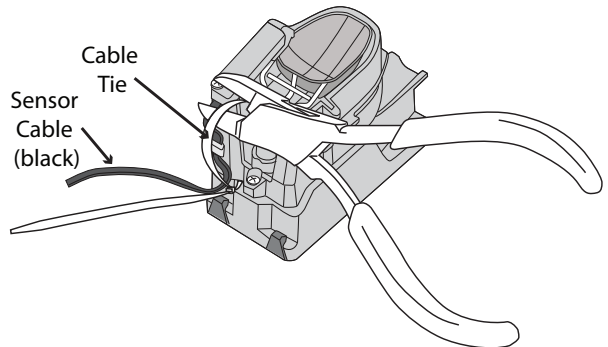

---

**CAUTION:** Be careful to not accidentally cut the sensor cable.

---

---

## Test the Rain Collector

Before installing the rain collector, test the unit. If you are replacing a rain collector you previously installed, make a note of the total rainfall amount displayed. You may want to reenter this amount after you test the rain collector.

1. Open the transmitter shelter on the sensor suite. Remove the foam insert from the cable port in the lower right corner and feed the rain collector cable up through the opening. Plug the cable into the appropriate connector in the sensor interface (See illustration on page 5.)
2. Press the RAINDAY button on your console to display rainfall.
3. While watching the display on your console to see if it changes, slowly tip the spoon until it drops and comes back up. Each tip indicates 0.01" or 0.2 mm of rain. (It may take up to a minute for the first tip to register at the console.) If the display does not change, you may be tipping the spoon too quickly. Try again, more slowly this time. If the rainfall amount displayed on the console increases by the expected increment (either 0.01" or 0.2 mm) each time you tip the spoon, your rain collector is working properly.
4. When you have finished testing, separate the cone from the base and disconnect the rain collector cable from the sensor interface in the transmitter shelter.

## Install the Rain Collector

### Choose a Location

Keep the following in mind when choosing a location for your rain collector:

- For accurate readings, **it is important that you mount the rain collector so that it is level.** A bubble level is built in to the base to simplify this process.
- The rain collector contains a magnet-operated switch which may not operate correctly if you mount the rain collector on or near any object which is attracted to a magnet.
- Exposure to winds can reduce the measured rainfall amounts. Mount the rain collector where there are no obstructions of rainfall at low angles -- such as trees, houses, fences -- and as low as possible out of the wind.
- Choose a location which is easily accessible for normal cleaning and is distant from trees or other sources of heavy pollen or debris.

---

Note: Climbing on your roof may be hazardous. If you are uneasy about installing your unit please have a qualified professional complete the installation. Davis specifically disclaims any liability for injury or loss resulting from the installation or use of the rain collector.

---

---

## Installing the Rain Collector on a Post or Vertical Surface

1. With a 3/16" (5 mm) drill bit, drill two holes approximately 2 1/8" (54 mm) apart. Use the metal backing plate as a guide when marking the holes and a carpenter's level to ensure the holes are level.
2. Remove the rain collector cone if it is installed.
3. Insert the 1/4" x 3" lag screws through the metal backing plate and the holes in the mounting base into the post. **Make sure the base is level by checking the built-in bubble level.**

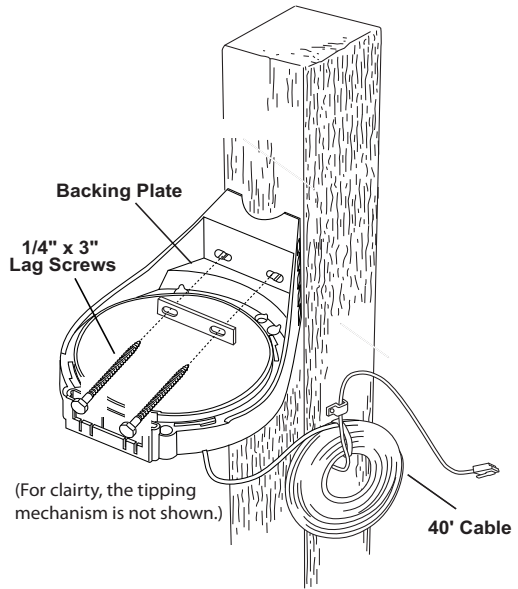

4. Tighten the lag screws using an adjustable wrench or 7/16" (11 mm) wrench.

## Installing the Rain Collector on a Pole

### Accessories for Pole Mounting

- Use the Mounting Tripod (#7716) for easy mounting.
- Use the Mounting Pole Kit (#7717) to raise the installation height of the rain collector by up to 37.5" (0.95 m).

### General Guidelines for Installing on a Pole

- With the supplied U-bolt, the rain collector can be mounted on a pole having an outside diameter ranging from 1 1/4" to 1 3/4" (32 – 44mm).
- A larger U-bolt (not supplied) can be used to mount to a pole with a maximum outside diameter of 2 1/2" (64mm).
- To mount on a smaller pole, obtain a U-bolt that fits the base openings but that has a shorter threaded section. If the included U-bolt is used with a smaller pole, the bolt will interfere with the rain collector cone.
- Use the built-in bubble level to ensure rain collector is level.

1. While holding the mounting base against the pole, place the two ends of a U-bolt around the pole and through the two holes in the base.

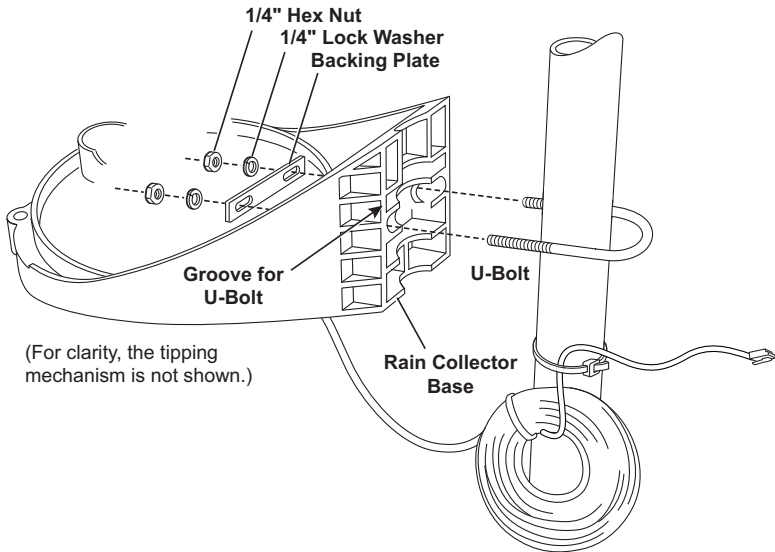

2. Slide the metal backing plate over the bolt ends as they stick out toward the rain collector cone. Secure the backing plate with a washer, a lock washer, and a hex nut on each of the bolt ends. Adjust the height of the rain collector, then tighten the nuts.

## Finishing Steps

1. Open the transmitter shelter on the sensor suite. Remove the foam insert from the cable port in the lower right corner and feed the rain collector cable up through the opening. Plug the cable to the receptacle in the transmitter labeled RAIN. Replace the foam and close the shelter.

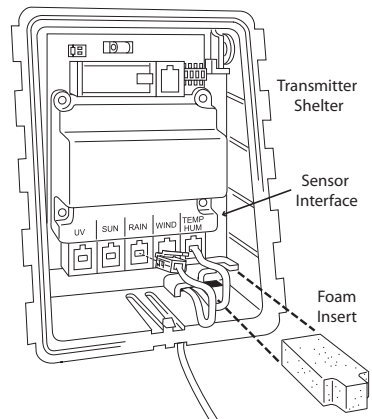

2. To be certain the rain collector is functioning properly after installation, retest the unit. See “Test the Rain Collector” on page 3.
3. Place the cone back onto the base by putting the latches on the cone into the latch openings in the base and rotating the cone clockwise until the latches “lock” into place. As you reattach the cone, make sure to run the cable to the cable slot in the base, or the cone will not fit snugly against the base. (You may also run the cable down through the hole in the base.)
4. Place the debris screen, pointed end up, into the cone. Align the locking grooves with the locks inside the cone and turn to lock the screen in place. If bird nesting is a problem, you can place a spike in the hole on top of the debris screen.
5. To use bird spikes, insert one spike into each socket around the rim of the cone. The sockets are tapered: push firmly or tap lightly with a hammer for a more secure fit. Be careful; bird spikes may be sharp.

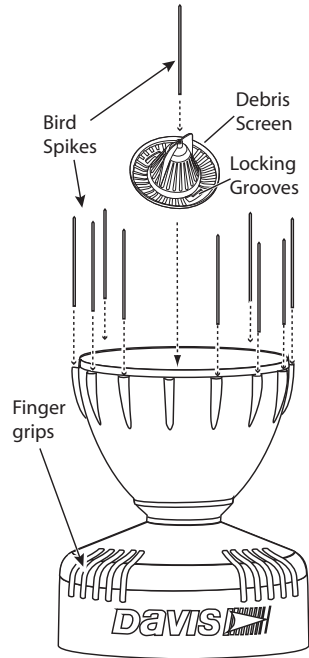

---

Note: If you choose not to install the bird spikes, we recommend that you keep the packet of spikes in case birds become a problem in the future.

---

6. To prevent fraying or cutting of the cable where it is exposed to weather, it is important that you secure it so it doesn't whip about in the wind. Use cable clips or weather resistant cable ties to secure the cable. Place clips or ties approximately every 3 to 5 feet (1 to 1.6 m). Do not use metal staples or a staple gun to secure cables. Metal staples, especially when installed with a staple gun, have a tendency to cut the cables.

## Extending Cable Runs

If the cable length supplied with the rain collector is not long enough for your purposes, you may extend it. The maximum length of cable is 900 feet (274 m). To extend the cable, purchase standard 4-Conductor Extension Cables from Davis and connect them to the existing rain collector cable.

---

## Maintaining the Rain Collector

For greatest accuracy, you should thoroughly clean the rain collector at least once or twice a year.

1. Disconnect the rain collector cable from the sensor interface in the transmitter shelter.
2. Separate the cone from the base.
3. Use a soft, damp cloth to clean pollen, dirt, and other debris from the cone, drain screens, and spoon.
4. Use a pipe cleaner to clear the funnel hole in the cone and the drain screens in the base. When all parts are clean, rinse with clear water.
5. Reattach the cone and replace the debris screen. Reconnect the rain collector cable to the sensor interface.

## Troubleshooting Guide

*Rainfall is not registering on the console or the console has a large error:*

- Check the cable connections from the sensor to the transmitter. Cable connections account for a large portion of the potential problems. Connections should be firmly seated in the jacks and plugged in straight. If a reading appears intermittently on the display as you jiggle the cable, the connection is faulty.
- Make sure there is no magnetic, steel, or iron object near the rain collector.
- Make sure the funnel hole in the cone is clear so water can empty into the spoon.
- Make sure the spoon moves freely and comes back up when tipping. The console should show an increase in rainfall for each tip of the spoon. (If the spoon does not move at all, check that you have cut the cable tie that held it in place during shipping.)
- **Make sure the rain collector is mounted so that it is level.**

## Contacting Davis Technical Support

If you have questions about your rain collector, or encounter problems installing or operating it, please contact Davis Technical Support.

---

Note: Please do not return items to the factory for repair without prior authorization.

---

<b>Online:</b>	<b><a href="http://www.davisinstruments.com">www.davisinstruments.com</a></b> See copies of user manuals, product specifications, application notes, software updates, and more.
<b>E-mail:</b>	<b><a href="mailto:support@davisinstruments.com">support@davisinstruments.com</a></b>
<b>Telephone:</b>	<b>(510) 732-7814</b> Monday – Friday, 7:00 a.m. – 5:30 p.m. Pacific Time

# Specifications

Sensor Type	Tipping spoon with magnetic switch
Output	Contact closure
Attached Cable	40' (12 m), 4-conductor, 26 AWG
Connector	Modular connector (RJ-11)
Recommended Max.Cable Length	900' (270 m)
Housing Material	UV-stabilized ABS plastic
Dimensions with base, no spikes	9.25" wide x 10.25" high x 11" deep (23.5 x 26 x 28 cm)
Collection Area	33.2 in <sup>2</sup> (214 cm <sup>2</sup> )
Range	
Daily Rainfall	0.00" to 99.99" (0.0 mm to 999.8 mm)
Total Rainfall	0.00" to 199.99" (0.0 mm to 6553 mm)
Accuracy	For rain rates up to 2"/hr (50 mm/hr): ±4% of total or +0.01" (0.2mm) (0.01" = one tip of the bucket) whichever is greater.
Update Interval	.20 - 24 seconds

## Input/Output Connections

(See the label on the side of the tipping spoon to verify version)

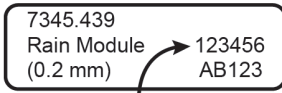

Version A (no letter before code)

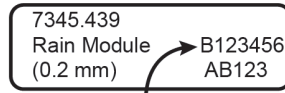

Version B ("B" before code)

### Version A

Red ..... Switch terminal  
Green & Yellow ..... Switch terminal

### Version B

Black..... Switch terminal  
Red..... Switch terminal

Product Number: 6466, 6466M Rain Collector      Part Number: 07395.365      Rev B (9/7/22)  
This product complies with the essential protection requirements of the EC EMC Directive 2004/108/EC.  
Vantage Pro, Vantage Vue, & EnviroMonitor are registered trademarks of Davis Instruments, Hayward, CA.  
Copyright © 2022 Davis Instruments Corp. All rights reserved. Davis Instruments Quality Management System is ISO 9001 certified. Information in this document is subject to change without notice.



3465 Diablo Avenue, Hayward, CA 94545-2778 U.S.A.

510-732-9229 • info@davisinstruments.com

www.davisinstruments.com