

Care Instructions

Valentine Bed

Valentine Bed – designed by Matthew Hilton

To prolong the life of the product and retain its appearance and functionality, we would like to give you some relevant information and care advice:

This unit is manufactured from either oak, black stained oak, or stained walnut.

European craftsmen manufacture this product and there is variety between each unit. This is because wood is a natural product, with natural colour and grain variations.

Natural timber is affected by sunlight; this can cause the wood colour to darken. For this reason (especially if placed in direct sunlight) it is recommended that placing objects in the same position for long periods of time is avoided. This potential colour adjustment becomes less relevant as the product ages.

It is recommended that no abrasive cleaners or solvents are used to clean the unit. Please only use proprietary furniture polishes or alternatively, warm water with a diluted mild detergent.

We thank you for purchasing this product and wish you many years of enjoyable and functional use.

For more related products please visit: casefurniture.com

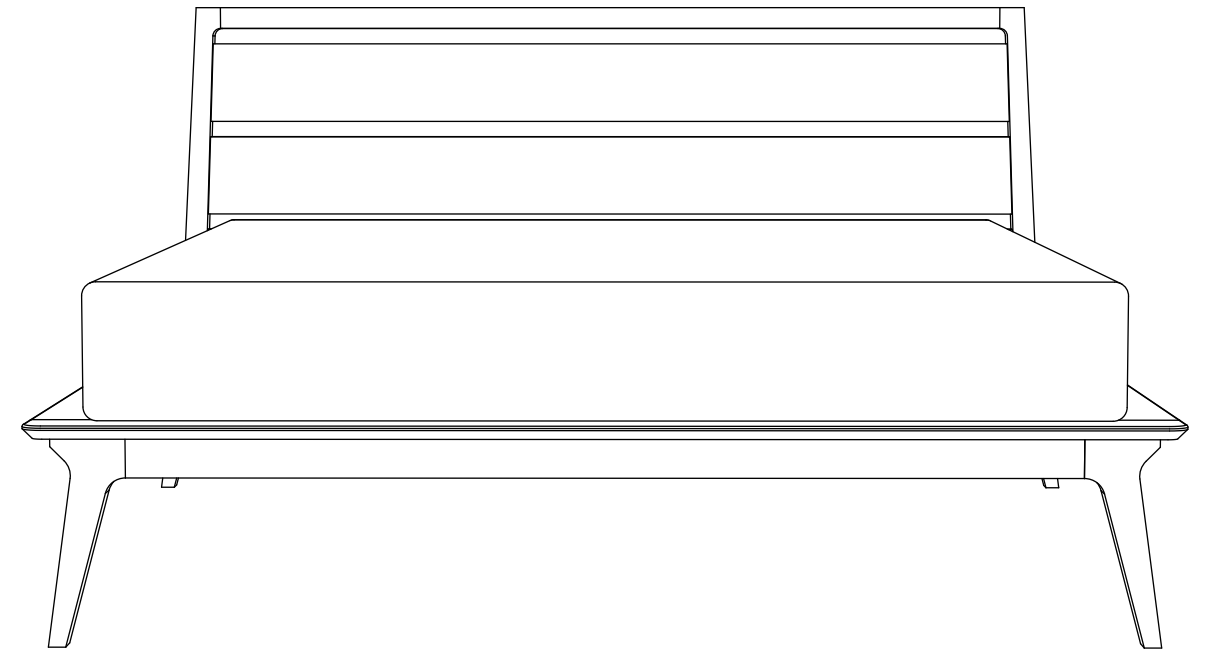

case

Case Furniture Ltd
London, SW18 2HZ
United Kingdom
info@casefurniture.com
casefurniture.com

case

Assembly Instructions

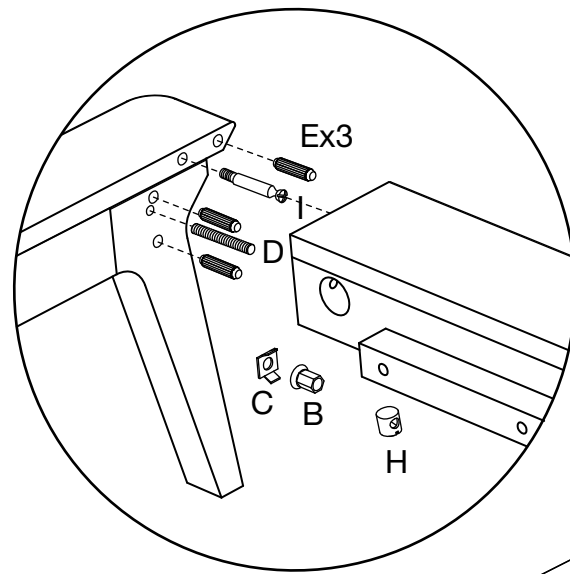
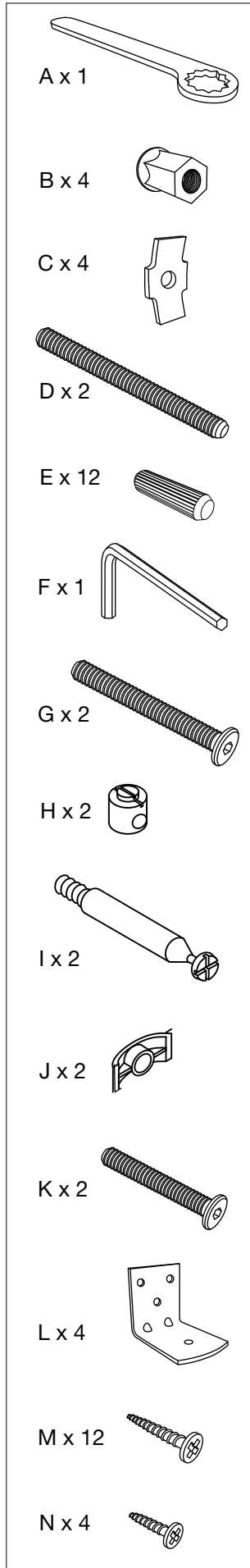

2 Insert threaded rod (D) and pin (I) as per the diagram and insert dowels (E) into the remaining holes in the foot end. Insert barrel cam (H) into the underside of the side rail. Push the foot end and side rail together and fully tighten using spanner (A) and fittings (B+C) with threaded rod (D) and a flathead screwdriver (not supplied) with barrel cam (H) and pin (I).

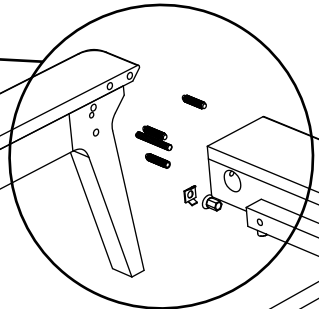

3 Attached brackets (L) using a crosshead screwdriver. (Not supplied) with screws (M).

Rest the crossbars in place on the brackets and attached using screw (N).

The slats rest on top bowing upwards.

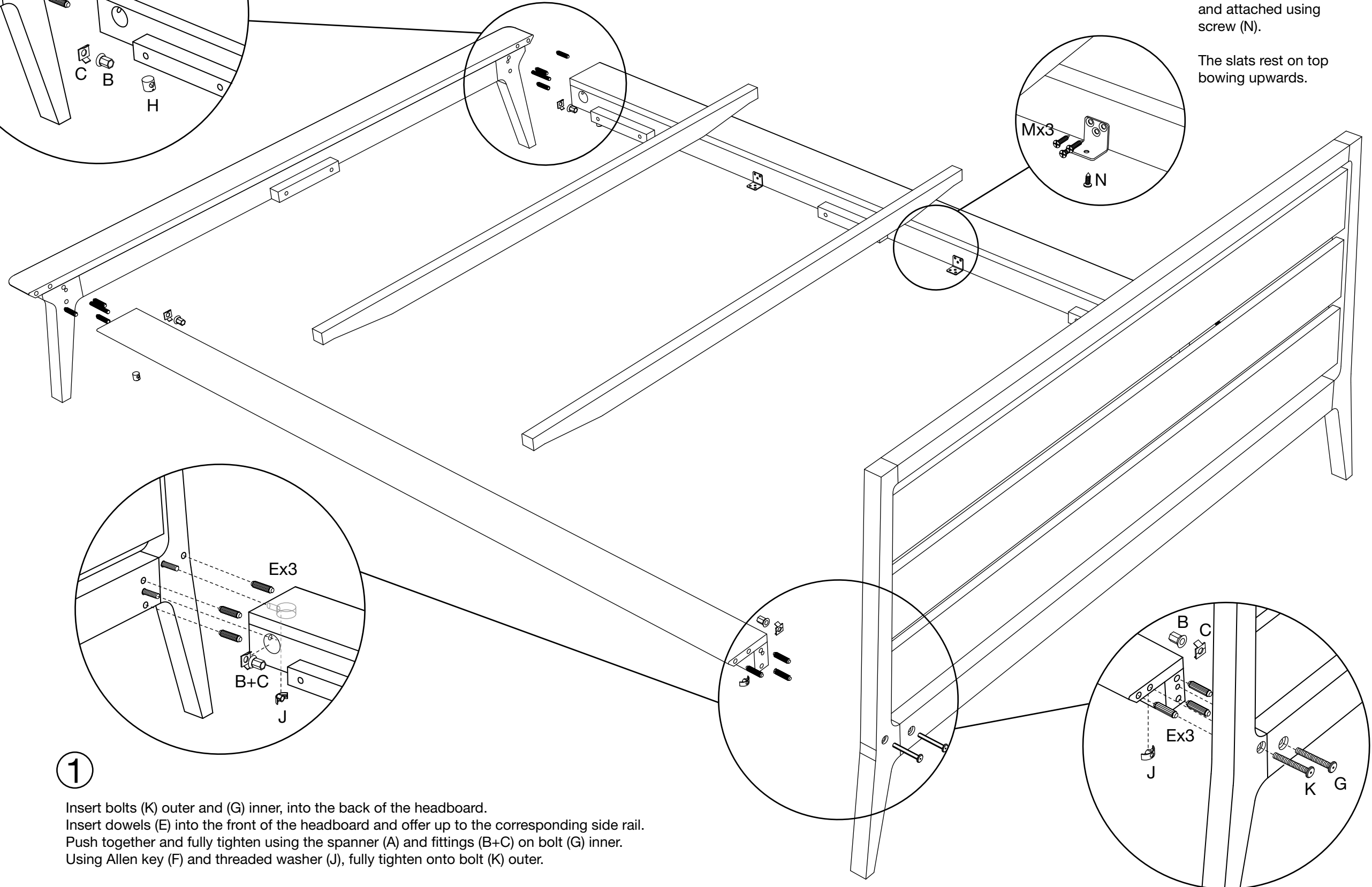
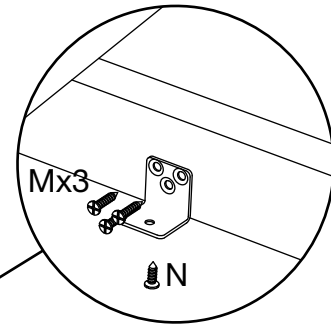

1 Insert bolts (K) outer and (G) inner, into the back of the headboard. Insert dowels (E) into the front of the headboard and offer up to the corresponding side rail. Push together and fully tighten using the spanner (A) and fittings (B+C) on bolt (G) inner. Using Allen key (F) and threaded washer (J), fully tighten onto bolt (K) outer.

