

# INSTRUCTIONS AND PARTS LIST

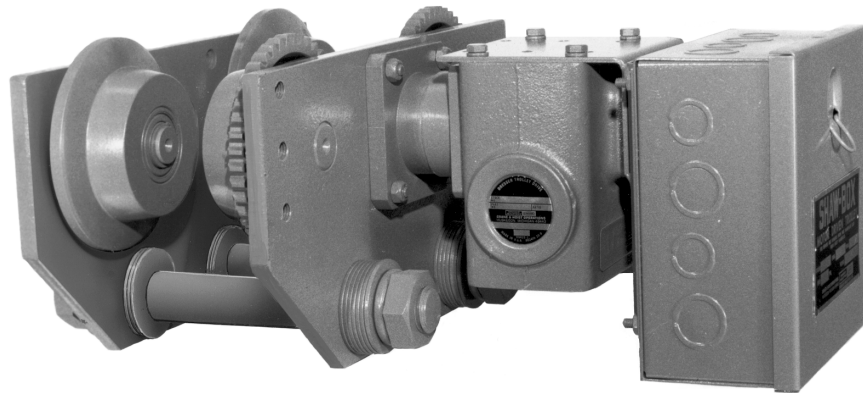

12681

# **SHAW-BOX<sup>®</sup>**

## MOTOR DRIVEN TROLLEYS

For 1/2 thru 15 ton SHAW-BOX Wire Rope Electric Hoists

## GENERAL

SHAW-BOX Motor Driven Trolleys are designed for use on SHAW-BOX Wire Rope Electric Hoists in rated loads from 1/2 through 15 tons. They are used singularly on standard lift hoists, or in combination with plain wheel trailer trolleys on low headroom or longer lift hoists.

These trolleys are built in three basic wheel sizes (single motor and/or double motor drive) to accommodate the entire range of rated loads offered in the SHAW-BOX hoist line. These sizes are 4" diameter wheels, 6-1/2" diameter wheels and 8" diameter wheels.

Push button station, ballast resistors, fuse kit and mainline contactor panels (all optional) will be mounted on trolley and completely wired into the trolley. Current collectors (when ordered) will be shipped loose.

The trolley (or trolleys on long lift and low headroom model hoists) mount on a special integral lug at top of hoist frame. Assembly of trolley(s) on hoist and installation of trolley-hoist unit on its runway beam can be accomplished with minimum effort by following the instructions given herein.

### ⚠ WARNING

**This equipment is not suitable or designed to be used in conjunction with lifting or lowering persons.**

**THE INFORMATION CONTAINED IN THIS MANUAL IS FOR INFORMATIONAL PURPOSES ONLY AND LIFT-TECH INTERNATIONAL DOES NOT WARRANT OR OTHERWISE GUARANTEE (IMPLIEDLY OR EXPRESSLY) ANYTHING OTHER THAN THE COMPONENTS THAT LIFT-TECH MANUFACTURES AND ASSUMES NO LEGAL RESPONSIBILITY (INCLUDING, BUT NOT LIMITED TO CONSEQUENTIAL DAMAGES) FOR INFORMATION CONTAINED IN THIS MANUAL.**

## ASSEMBLY OF TROLLEY TO HOIST

1. Before installing trolley on hoist, determine the proper orientation of hoist.

a. On both single-motor and two-motor trolleys, except on low headroom model hoists, position trolley so that its electrical control panel is on the same side as the electrical compartment of the hoist. **Note:** On long lift model hoists, locate motor driven trolley on mounting lug at motor end of hoist and trailer trolley at opposite end.

b. On low headroom model hoists, locate motor driven trolley on mounting lug at drum side of hoist, with electrical control panel toward gear case end. A 2-wheel or 4-wheel trailer trolley mounts on opposite, or electrical compartment side of hoist.

2. Determine proper trolley side plate spacing to assure that adequate wheel clearance (approximately 1/8") is provided on both sides of I-beam, between edges of bottom beam flange and inside faces of wheel flanges. Proper spacing is obtained by varying the number of spacer washers (furnished with trolley) that are installed on suspension pins, between hoist lug and trolley side plates. See Figure 1.

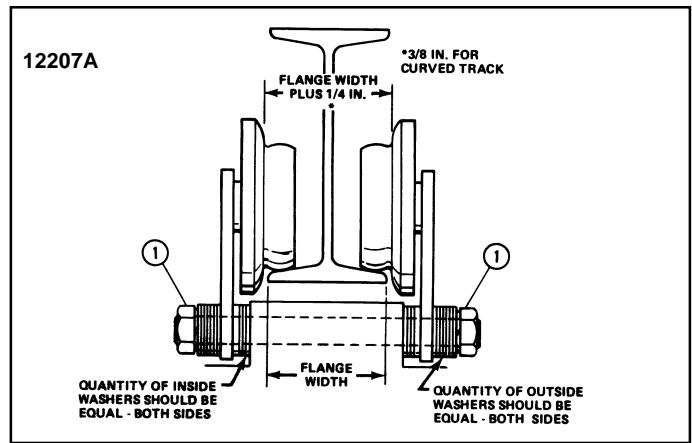

Figure 1. Proper Wheel Spacing

3. Due to manufacturing tolerances, I-beams having the same size designations may have varying dimensions making it impossible to prescribe the specific number of spacer washers required between trolley side plates and suspension lug for any given beam size. It will, therefore, be necessary to determine the spacer washer requirement by "trial and error" assembly.

a. First measure the exact width of bottom flange on runway beam, and then add 1/4" to that measurement (3/8" for curved beam). The total is the required distance between inside faces of wheel flanges to obtain satisfactory wheel operating clearance. See Figure 1.

b. Temporarily assemble trolley to hoist using about 3 or 4 washers at each end of suspension pins, between side plates and suspension lug. Tighten pin nuts for accurate check of spacing.

c. Measure distance between inside faces of wheel flanges and compare with the total dimension obtained in paragraph a. above.

d. Remove trolley sides and add or remove an equal number of inside spacer washers as required to obtain proper distance between wheels.

e. When wheel spacing is correct, remaining spacer washers are to be installed on outside ends of suspension pins (see note below) and the pins then secured with lockwashers and hex nuts. The nuts (1, Figure 1) should not be completely tightened until after hoist and trolley are mounted on runway beam.

**Note:** It is important that all spacer washers that come with trolley be used. Install remaining spacer washers equally on outside ends of pins.

4. Open cover on trolley electrical panel enclosure. Remove one knockout from enclosure and thread hoist flexible cable leads through hole. Secure box type connector with locknut and connect leads to terminal strip in accordance with appropriate wiring diagrams furnished with trolley.

## CURRENT COLLECTORS

1. Current collectors are not standard and must be ordered as an option. They are shipped in a separate carton and must be installed in field.

2. Determine collector arrangement on trolley before starting assembly (i.e., whether all on one side or on two sides.)
3. Assemble collector bracket with hardware provided. Secure lightly for later adjustment.
4. Arrange collectors on pole in approximate locations and finger tighten to pole.
5. Open cover on trolley electrical panel. Feed wire leads from collector shoe terminals into trolley electrical panel through box type connector in enclosure. Connect collector wire leads to terminal strip in accordance with appropriate wiring diagrams furnished with trolley. Close panel cover.
6. If trolley is equipped with a mainline disconnect panel and/or fuse panel, connect the collector wire leads per "Fuse and Mainline Disconnect Panels" section.

### INSTALLING TROLLEY AND HOIST

1. Hoist and trolley combination may be installed on runway beam by either of two methods.

<b>⚠ WARNING</b>
<b>Be certain that electrical power supply to runway current conductors (if used) is "off" and locked in the open position.</b>

- a. If one end of beam is open or exposed, trolley may be installed by sliding it onto beam.
- b. If trolley cannot be slid over end of beam, remove hex nuts (1, Figure 1), lockwashers and outer spacer washers from pins on one side of trolley. Spread or remove one side plate to facilitate positioning trolley over bottom flange of beam. Reinstall, side plate, outer spacer washers, lockwashers and hex nuts on suspension pins.

<b>⚠ WARNING</b>
<b>After trolley has been installed on beam, make sure suitable stop(s) is secured on open ended beams to prevent trolley from rolling off the beam. (Stops should contact trolley side plates, not wheels.) Make certain that all spacer washers and lockwashers are in place on suspension pins and that hex nuts are tight. Recheck clearance dimension between wheel flanges and beam flanges (Figure 1).</b>

2. Engage slide collector shoes with runway conductor bars and make final adjustment to pole bracket and collector spacing. Tighten securely.

<b>⚠ CAUTION</b>
Power supply must be same voltage, phase and frequency as specified on hoist and trolley motor nameplates.

3. Follow National, State and Local electrical codes when providing electrical service to hoist and trolley. Make electrical

connections using the wiring diagrams furnished with the trolley and the wiring diagram furnished with the hoist. **Do not attempt to operate trolley or hoist before completing "Pre-Operation Checks and Adjustments."**

<b>⚠ WARNING</b>
<b>This equipment must be effectively grounded according to the National Electrical Code, or other applicable codes. If the grounding method used is through the trolley wheels, then each section of track must be grounded by metal-to-metal connection to the building ground. Certain environments may prevent proper grounding by this means and in this case a separate grounding conductor should be provided.</b>

### ATTACH PUSH BUTTON STATION STRAIN CABLE

Trolleys ordered for use with hoists are shipped from the factory with the upper end of the push button station strain cable unconnected. If this is the case, it will be necessary to remove rope thimble from loose end of strain cable and attach strain cable as shown in either Figure 2 or Figure 3.

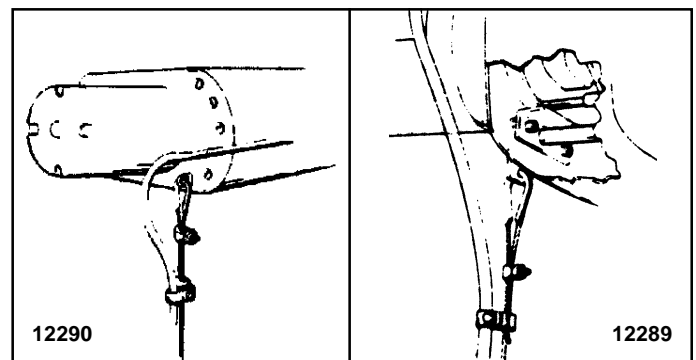

**Figure 2. Push Button Strain Cable Attachment to Series 700 SHAW-BOX Hoist.**

**Figure 3. Push Button Strain Cable Attachment to Series 800 SHAW-BOX Hoist.**

### CONNECTING TROLLEY TO ELECTRICAL SERVICE

1. Follow Local, State and National Electric Codes when providing electrical service to hoist. Connect wires in accordance with appropriate trolley wiring diagram. Be certain that the electrical power supply is the same as specified on trolley and hoist motor data plates.
2. Common methods of connecting trolley to power supply are current collectors, previously described and flexible cable (tag line, festooned or cable reel).

**Note:** A grounding type male plug or permanent connection in an outlet box may be used for wiring tag line or festooned cable to power supply.

<b>⚠ CAUTION</b>
Power supply must be same voltage, frequency and phase as specified on hoist and trolley nameplates.

## ⚠WARNING

All equipment must be effectively grounded electrically.

### PRE-OPERATION CHECKS AND ADJUSTMENTS

#### 1. Check Push Button Operation and Phasing.

## ⚠WARNING

On three phase hoists it is possible to have "Reverse Phasing" causing the lower block to lower when the "Up" button is depressed. When this condition exists the automatic limit stop switch is inoperative and hoist operation will be dangerous.

a. To properly check the phase of the hoist, follow steps below:

- (1) With "POWER OFF" operate the "START", "STOP" and "UP" push buttons and determine that they do not bind or stick in any position. DO NOT REMOVE WARNING TAG or test "DOWN" push button at this time.

## ⚠WARNING

If any push button binds or sticks in any position - DO NOT TURN POWER ON - determine the cause and correct the malfunction before operating.

- (2) Temporarily connect hoist to power source.
- (3) Operate "UP" button briefly to determine direction of hook travel.
- (4) If hook raises, phase is correct. Turn power off and make temporary connections permanent.
- (5) If hook lowers, hoist is "Reverse Phased." TURN POWER OFF and correct by interchanging any two leads at power source connection. Do not change internal wiring of hoist.

b. The red WARNING TAG should be removed from push button cable only after it has been determined that the hoist is correctly phased. With "POWER OFF" the "DOWN" button should now be checked for freedom of operation. If malfunction exists, correct before operating with power.

2. Observe and perform all pre-operation checks required for the hoist, as outlined in the "Hoist Operation, Service and Parts Manual" furnished with the hoist.

3. **Check Trolley Travel Directions.** With trolley-hoist unit positioned on I-beam so that there is clear track to allow travel in each direction, check both "RIGHT" and "LEFT" traverse operation.

**Note:** When it is desired to change direction of trolley travel in relation to push button markings, turn POWER OFF and interchange connections of motor leads "CT-1" and "CT-2" at trolley contactor "L" on single speed trolleys. Be certain to interchange connections on both

motors on 2-motor trolleys. For two speed trolleys, interchange wires "A" and "C" at trolley contactor "L".

#### 4. Adjust Ballast Resistors (if furnished).

a. Ballast resistors installed on 3 phase motor driven trolleys provide a "cushion-start" effect which is helpful in reducing load swing during acceleration. It will be necessary to adjust resistor slide bands under load as directed below to obtain the desired rate of acceleration.

## ⚠WARNING

Ballast resistors are neither suitable nor intended for use in reducing maximum trolley running speed.

b. Resistor slide bands (taps) are approximately set when shipped from factory. Field adjustments for desired acceleration should be made by user with maximum load to be moved suspended from hoist as follows:

- (1) Turn power "OFF" at power source.
- (2) Remove resistor cover. Discard any paper covering resistors.
- (3) Loosen the three slide bands and move them to the extreme end to which jumpers are attached. This provides maximum resistance resulting in reduced motor voltage and motor torque.

## ⚠CAUTION

To prevent damage to trolley motor, be certain the three slide bands are IN-LINE HORIZONTALLY on their respective resistors after any adjustment. DO NOT ROTATE slide bands on their resistors. This may cause electrical shorting.

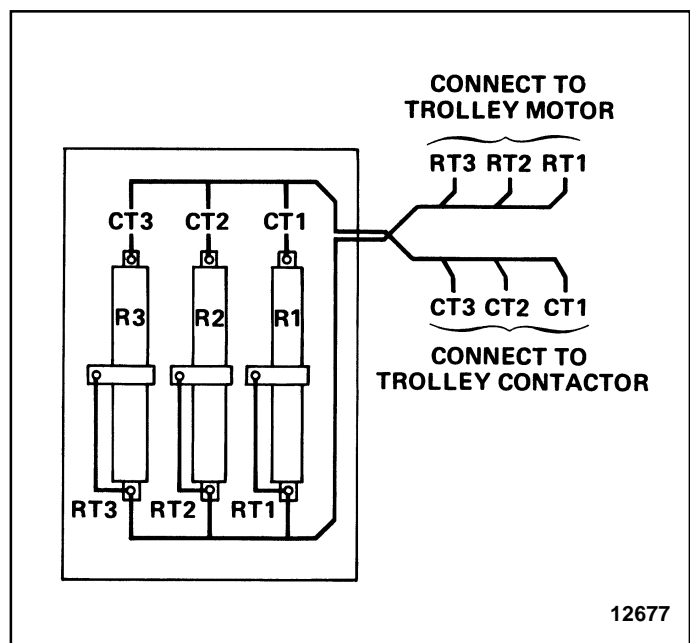

Figure 5. Resistor Wiring Diagram

(4) Turn Power "ON" and with maximum load to be traversed suspended from hoist, press "RIGHT" or "LEFT" trolley button and note speed of trolley acceleration. If trolley does not move or accelerates too slowly, turn power "OFF" and move all three slide bands approximately 1" away from jumper end. Turn power on and repeat above test. Continue above procedure until desired acceleration is obtained.

(5) Replace resistor cover.

**FUSE AND MAINLINE DISCONNECT PANELS**

Mainline disconnect panels and/or hoist-trolley fuse panels are provided as options on motor driven trolleys to assist users in complying with OSHA codes. When ordered with trolley, they will be completely installed on trolley and wired into trolley electrical system.

Electrical service is to be connected to trolleys equipped with fuse panels and/or mainline disconnect panels as follows:

1. Fuse Panels Only. Connect leads from power supply to hoist fuse terminals "L-1", "L-2" and "L-3" (3-phase) under hoist fuses. See trolley wiring diagram.
2. Mainline Disconnect (furnished with fuse panels only). Connect power supply leads "ML-1", "ML-2" and "ML-3" (3-phase) to the upper power terminals of mainline contactor. Refer to trolley wiring diagram.

<b>CAUTION</b>
Power supply must be same voltage, frequency and phase as specified on hoist and trolley nameplates.

**MAINTENANCE AND LUBRICATION**

1. SHAW-BOX Motor Driven Trolleys are built to give long service, but should be inspected periodically for evidence of damage or wear, particularly when subjected to unusually severe operating conditions.
  - a. Wheel bearings have grease sealed in and require no additional lubricant.

- b. Drive wheel gears are to be lubricated with an open type gear grease which is heavy, plastic, extreme pressure and tacky; such as MOBILTAC 275 NC or equal.
- c. The right angle worm gear reducer oil is a synthetic lubricant with excellent wear protection capability and long life. This oil does not require changing. When replacing oil due to repairs, use MOBIL SHC 634 or equal.

**REPLACEMENT PARTS**

The following parts lists and illustrations cover standard model SHAW-BOX motor driven trolleys. Typical units are used as the basis for the exploded parts illustrations; therefore, certain variations may occur from the parts information given. For this reason always give the catalog number, model number, motor horsepower, voltage, phase and frequency of trolley when ordering replacement parts. For motors, gearboxes and electrical components, give complete nameplate data. Pins referred to in some column headings are trolley suspension pins. The symbol  $\varnothing$  indicates diameter.

These SHAW-BOX motor driven trolleys are built in three basic wheel sizes. They are 4" diameter wheels, 6-1/2" diameter wheels, and 8" diameter wheels. When selecting parts from the following parts list, be sure to use appropriate illustration and parts table for your particular trolley size, based on wheel size and whether it is a single or two motor trolley.

The factory recommends complete replacement of the motor or gearbox. Gearbox service is available, however, from your local authorized SHAW-BOX repair station.

<p><b>The numbers assigned to the parts of our various assemblies in our parts lists are not the part numbers used in manufacturing the part. They are identification numbers, that when given with the trolley serial number, permit us to identify, select or manufacture, and ship the correct part needed for any trolley.</b></p> <p><b>Supply Complete numbers from the identification plate of the gearbox that match the numbers (including digits - where x's appear) in the lower right hand corner of the parts illustration for the motor and gearbox assemblies.</b></p>
---

<b>INDEX OF PARTS ILLUSTRATIONS</b>		
Title	Figure No.	Page No.
Trolley Frame and Wheels - One Motor (4" Dia. Wheels - 3-1/8 & 5" c/c Pins) .....	6	6
Trolley Frame and Wheels - One Motor (4" Dia. Wheels - 6" c/c Pins) .....	7	7
Trolley Frame and Wheels - One Motor (6-1/2" Dia. & 8" Dia. Wheels) .....	8	8
Trolley Frame and Wheels - Two Motor. (4" Dia. Wheels) .....	9	9
Trolley Frame and Wheels Two Motor (6-1/2" Dia. & 8" Dia. Wheels) .....	10	10
Motor and Gearbox Assembly (3-1/8" & 5" c/c Pins) .....	11	12
Motor and Gearbox Assembly (6", 9" & 16" c/c Pins) .....	12	13
Electrical Enclosure Mountings .....	13	14
Electrical Enclosures .....	14	15
Push Button Station and Conductor Cable Assembly .....	15	17
Current Collectors .....	16	19
Ballast Resistors .....	--	19

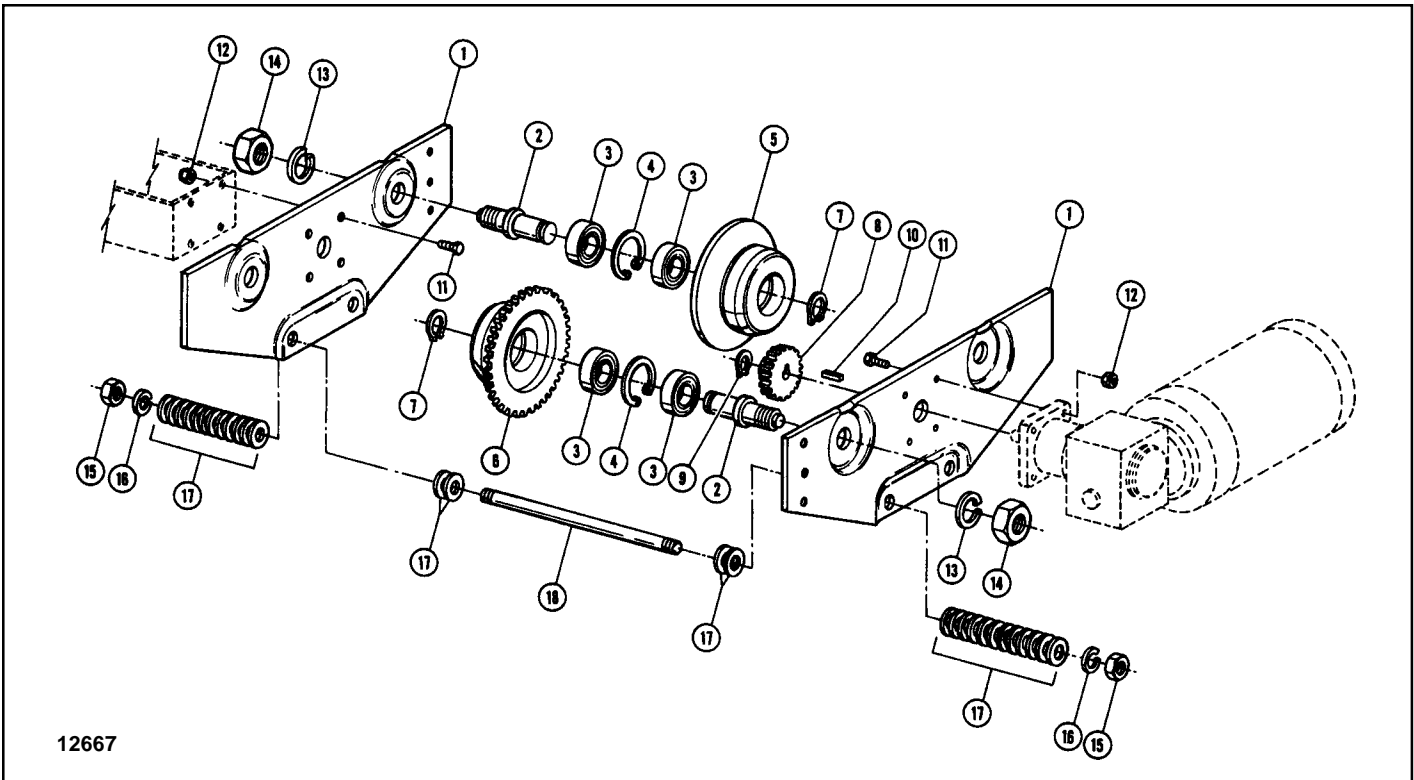

**Figure 6. Trolley Frame and Wheels - One Motor**  
**(4"Ø Wheels - 3-1/8" & 5" c/c Pins)**

Ref. No.	Description	3-1/8" c/c Pins		5" c/c Pins	
		Part Number	Qty. Req'd.	Part Number	Qty. Req'd.
1	Plate Assembly - Side For 3" to 5" Flange Widths and Patented Track For 5-1/8" to 7-1/4" Flange Widths For 7-1/2" to 9-1/8" Flange Widths For 3-5/8" to 6" Flange Widths and Patented Track For 6-1/4" to 8-5/8" Flange Widths. For 8-7/8" to 11-1/4" Flange Widths	SBT-3600	2	--	--
		SBT-3601	2	--	--
		SBT-3602	2	--	--
		--	--	SBT-3603	2
		--	--	SBT-3604	2
		--	--	SBT-3605	2
2	Shaft - Wheel	SBT-3606	4	SBT-3606	4
3	Bearing - Ball	SBT-3607	8	SBT-3607	8
4	Ring - Retaining	SBT-3608	4	SBT-3608	4
5	Wheel - Plain (Except Patented Track) For Patented Track Only	SBT-3609	2	SBT-3609	2
		SBT-3610	2	SBT-3610	2
6	Wheel - Geared (Except Patented Track) For Patented Track Only	SBT-3611	2	SOT-3611	2
		SBT-3612	2	SBT-3612	2
7	Ring - Retaining	SBT-3613	4	SBT-3613	4
8	Pinion - Motor	SBT-3614	1	SBT-3615	1
9	Ring - Retaining	SBT-3616	1	SBT-3616	1
10	Key - Motor Pinion	SBT-3617	1	SBT-3617	1
11	Screw - Hex Cap	SBT-3618	8	SBT-3618	8
12	Nut - Self-locking	SBT-3619	8	SBT-3619	8
13	Lockwasher	SBT-3620	4	SBT-3620	4
14	Nut - Hex Jam	SBT-3621	4	SBT-3621	4
15	Nut - Hex Jam	SBT-3622	4	SBT-3622	4
16	Lockwasher	SBT-3623	4	SBT-3633	4
17	Washer - Spacer	SBT-3624	56	SBT-3625	36
18	Pin - Suspension For 3" to 5" Flange Widths and Patented Track For 5-1/8" to 7-1/4" Flange Widths For 7-1/2" to 9-1/8" Flange Widths For 3-5/8" to 6" Flange Widths and Patented Track For 6-1/4" to 8-5/8" Flange Widths For 8-7/8" to 11-1/4" Flange Widths	SBT-3626	2	--	--
		SBT-3627	2	--	--
		SBT-3628	2	--	--
		--	--	SST-3629	2
		--	--	SBT-3630	2
		--	--	SST-3631	2

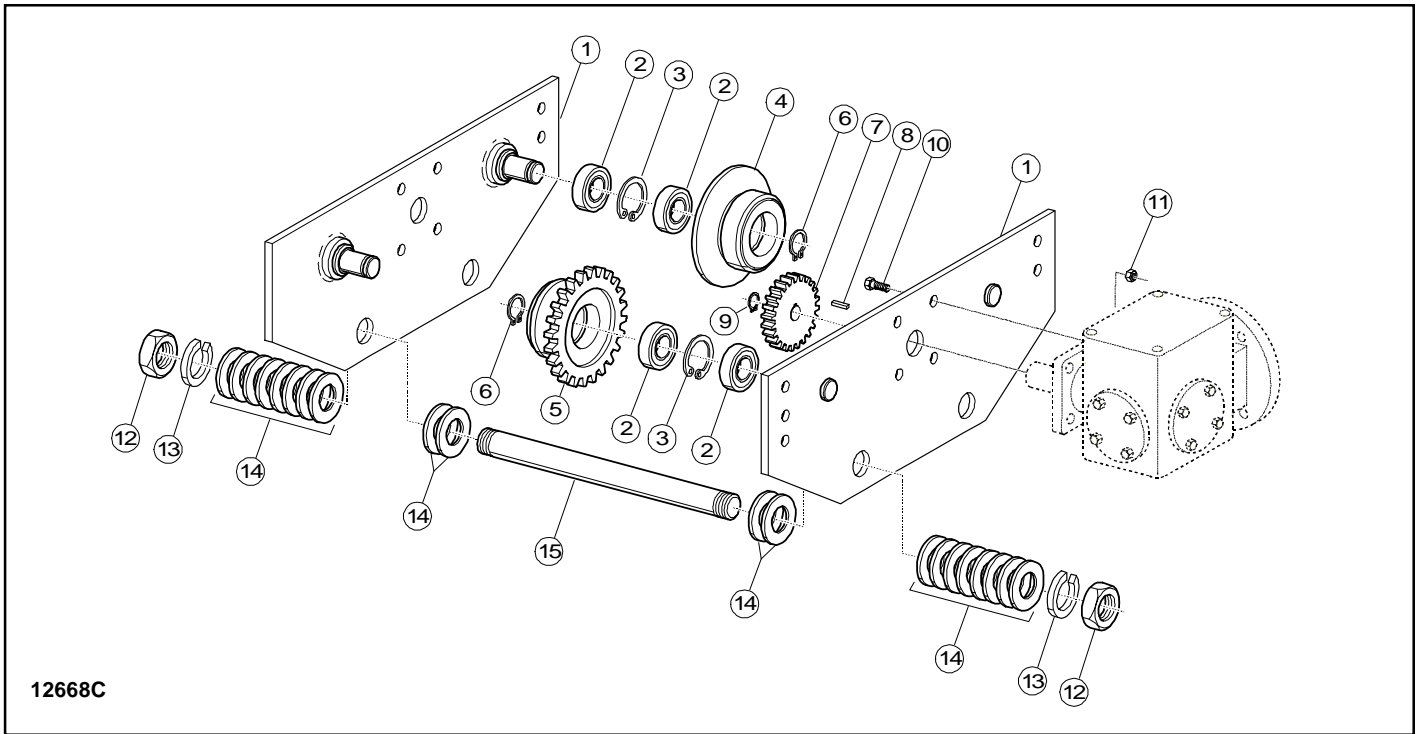

12668C

**Figure 7. Trolley Frame and Wheels - One Motor  
(4"  $\phi$  Wheels & 6" c/c Pins)**

Ref. No.	Part Number	Description	Qty. Req'd.
1	SBT-3700	Plate Assembly-Side For 4" to 6-1/4" Flange Widths and Patented Track	2
	SBT-3701	For 6-3/8" to 8-5/8" Flange Widths	2
	SBT-3702	For 8-3/4" to 11" Flange Widths	2
2	SBT-3703	Bearing - Ball	8
3	SBT-3704	Ring - Retaining	4
4	SBT-3705	Wheel - Plain (Except Patented Track)	2
	SBT-3706	For Patented Track Only	2
5	SBT-3707	Wheel - Geared (Except Patented Track)	2
	SBT-3708	For Patented Track Only	2
6	SBT-3709	Ring - Retaining	4
7	SBT-3710	Pinion - Motor	1
8	SBT-3711	Key - Motor Pinion	1
9	SBT-3712	Ring - Retaining	1
10	SBT-3713	Screw - Hex Cap	4
11	SBT-3714	Nut - Self-locking	4
12	SBT-3715	Nut - Hex Jam	4
13	SBT-3716	Lockwasher	4
14	SBT-3717	Washer - Spacer	40
15		Pin -Suspension	
	SBT-3718	For 4" to 6-1/4" Flange Widths and Patented Track	2
	SBT-3719	For 6-3/8" to 8-5/8" Flange Widths	2
	SBT-3720	For 8-3/4" to 11" Flange Widths	2

### Notes

---



---



---



---

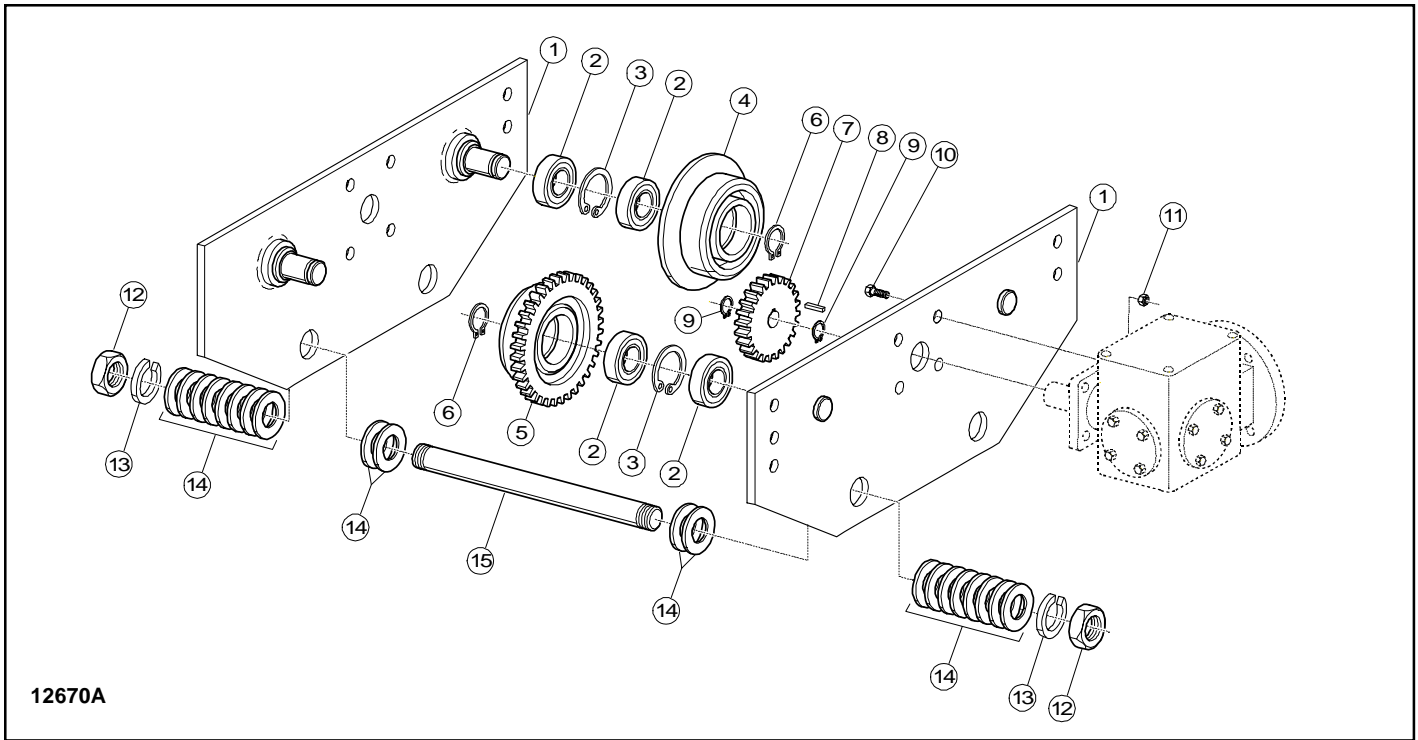

12670A

**Figure 8. Trolley Frame and Wheels - One Motor  
(6-1/2"Ø & 8"Ø Wheels)**

Ref. No.	Description	6-1/2"Ø Wheels			8"Ø Wheels		
		1-1/4"Ø Pins	1-1/2"Ø Pins	Qty. Req'd.	9" c/c Pins	16" c/c Pins	Qty. Req'd.
		Part No.	Part No.		Part No.	Part No.	
1	Plate Assembly -Side						
	For 4" to 6-1/4" Flange Widths and Patented Track	SBT-3800	SBT-3801	2	--	--	--
	For 6-3/8" to 8-5/8" Flange Widths	SBT-3802	SBT-3803	2	--	--	--
	For 8-3/4" to 11" Flange Widths	SBT-3804	SBT-3805	2	--	--	--
	For 6" to 8-1/2" Flange Widths	--	--	--	SBT-3806	SBT-3806	2
	For 8-5/8" to 11-1/8" Flange Widths	--	--	--	SBT-3807	SBT-3808	2
	For 11-1/4" to 13-3/4" Flange Widths	--	--	--	SBT-3809	SBT-3810	2
2	Bearing - Ball	SBT-3811	SBT-3811	8	SBT-3812	SBT-3812	8
3	Ring - Retaining	SBT-3813	SBT-3813	4	SBT-3814	SBT-3814	4
4	Wheel - Plain (Except Patented Track)	SBT-3815	SBT-3815	2	SBT-3816	SBT-3816	2
	For Patented Track Only	SBT-3817	SBT-3817	2	--	--	--
5	Wheel- Geared (Except Patented Track)	SBT-3818	SBT-3818	2	SBT-3819	SBT-3819	2
	For Patented Track Only	SBT-3820	SBT-3820	2	--	--	--
6	Ring - Retaining	SBT-3821	SBT-3821	4	SBT-3822	SBT-3822	4
7	Pinion - Motor *	SBT-3823	SBT-3823	1	SBT-3823	SBT-3823	1
8	Key - Motor Pinion	SBT-3824	SBT-3824	1	SBT-3824	SBT-3824	1
9	Ring - Retaining	SBT-3825	SBT-3825	2	SBT-3825	SBT-3825	2
10	Screw - Hex Cap	SBT-3826	SBT-3826	4	SBT-3827	SBT-3827	4
11	Nut - Self-locking	SBT-3828	SBT-3828	4	SBT-3828	SBT-3828	4
12	Nut - Hex Jam	SBT-3829	SBT-3830	4	SBT-3831	SBT-3831	4
13	Lockwasher	SBT-3832	SBT-3833	4	SBT-3834	SBT-3834	4
14	Washer - Spacer	SBT-3835	SBT-3836	40	SBT-3837	SBT-3837	44
15	Pin - Suspension						
	For 4" to 6-1/4" Flange Widths and Patented Track	SBT-3838	SBT-3839	2	--	--	--
	For 6-3/8" to 8-5/8" Flange Widths	SBT-3840	SBT-3841	2	--	--	--
	For 8-3/4" to 11" Flange Widths	SBT-3842	SBT-3843	2	--	--	--
	For 6" to 8-1/2" Flange Widths	--	--	--	SBT-3844	SBT-3844	2
	For 8-5/8" to 11-1/8" Flange Widths	--	--	--	SBT-3845	SBT-3845	2
	For 11-1/4" to 13-3/4" Flange Widths	--	--	--	SBT-3846	SBT-3846	2

\*Pinion shoulder away from side plate for 6-1/2"Ø wheels and toward side plate for 8"Ø wheels.



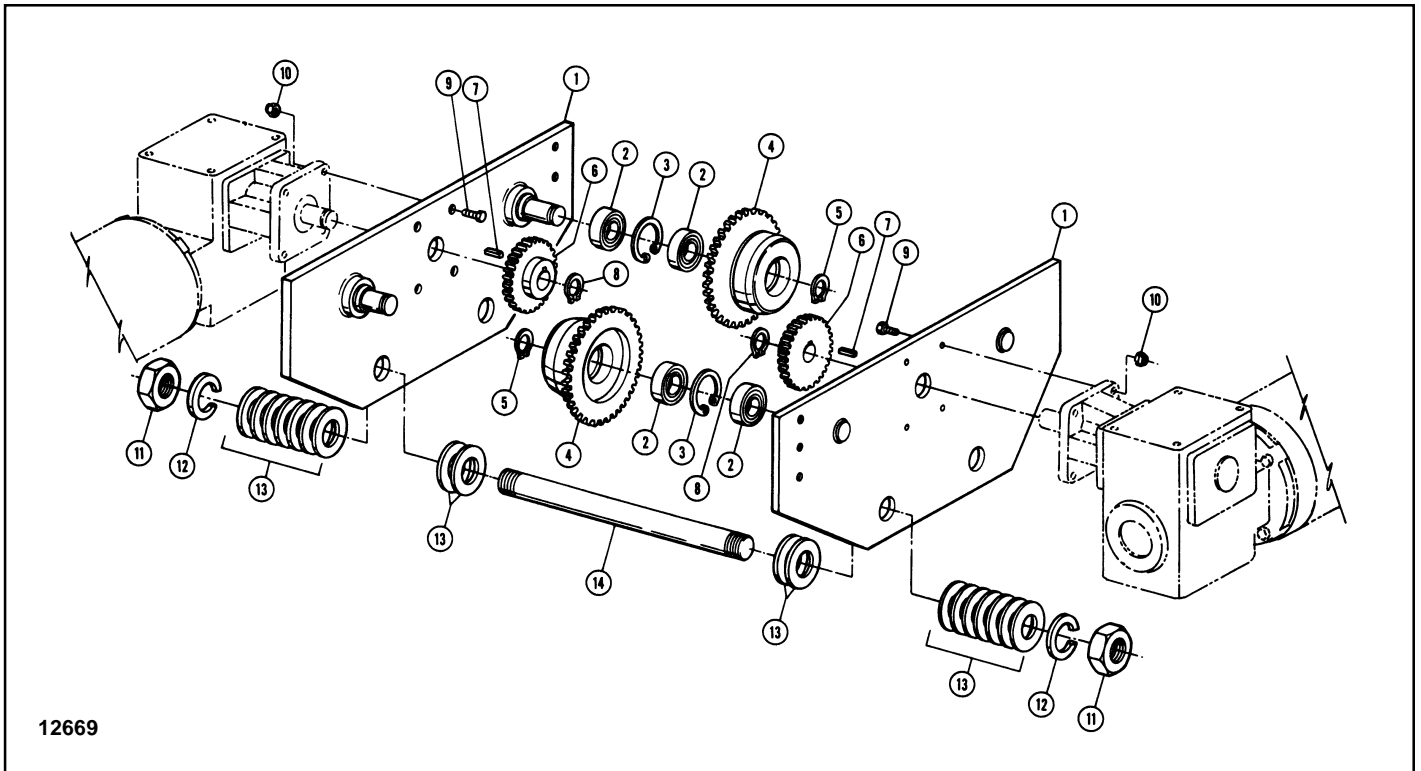

12669

**Figure 9. Trolley Frame and Wheels - Two Motors  
(4"Ø Wheels)**

Ref. No.	Part Number	Description	Qty. Req'd.
1	SBT-3900	Plate Assembly - Side For 4" to 6-1/4" Flange Widths and Patented Track	2
	SBT-3901	For 6-3/8" to 8-5/8" Flange Widths	2
	SBT-3902	For 8-3/4" to 11" Flange Widths	2
2	SST-3903	Bearing - Ball	8
3	SBT-3904	Ring - Retaining	4
4	SBT-3905	Wheel - Geared (Except Patented Track)	4
	SBT-3906	For Patented Track Only	4
5	SBT-3907	Ring - Retaining	4
6	SBT-3908	Pinion - Motor	2
7	SBT-3909	Key - Motor Pinion	2
8	SBT-3910	Ring - Retaining	2
9	SBT-3911	Screw - Hex Cap	8
10	SBT-3912	Nut -Self-locking	8
11	SBT-3913	Nut - Hex Jam	4
12	SBT-3914	Lockwasher	4
13	SBT-3915	Washer - Spacer	40
14		Pin - Suspension	
	SBT-3916	For 4" to 6-1/4" Flange Widths and Patented Track	2
	SBT-3917	For 6-3/8" to 8-5/8" Flange Widths	2
	SBT-3918	For 8-3/4" to 11" Flange Widths	2

**Notes**

---



---



---



---

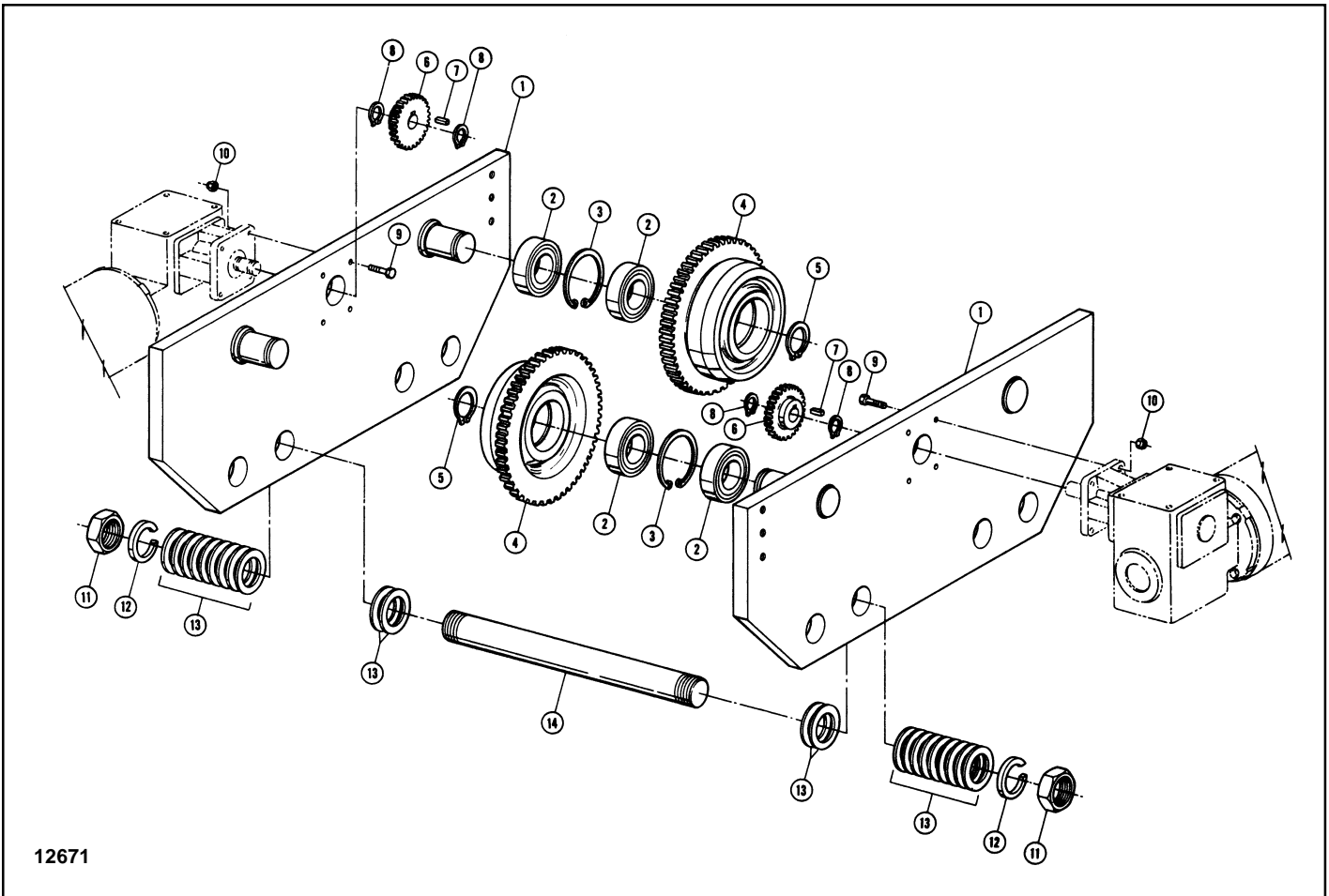

12671

**Figure 10. Trolley Frame and Wheels - Two Motors  
(6-1/2"Ø & 8"Ø Wheels)**

Ref. No.	Description	6-1/2"Ø Wheels			8"Ø Wheels		
		1-1/4"Ø Pins	1-1/2"Ø Pins	Qty.	9" c/c Pins	16" c/c Pins	Qty.
		Part No.	Part No	Req'd.	Part No.	Part No.	Req'd.
1	Plate Assembly - Side For 4" to 6-1/4" Flange Widths and Patented Track	SBT-4000	SBT-4001	2	--	--	--
	For 6-3/8" to 8-5/8" Flange Widths	SBT-4002	SBT-4003	2	--	--	--
	For 8-3/4" to 11 " Flange Widths	SBT-4004	SBT-4005	2	--	--	--
	For 6" to 8-1/2" Flange Widths	--	--	--	SBT-4006	SBT-4006	2
	For 8-5/8" to 11-1/8" Flange Widths	--	--	--	SBT-4007	SBT-4008	2
	For 11-1/4" to 13-3/4" Flange Widths	--	--	--	SBT-4009	SBT-4010	2
2	Bearing - Ball	SBT-4011	SBT-4011	8	SBT-4012	SBT-4012	8
3	Ring - Retaining	SBT-4013	SBT-4013	4	SBT-4014	SBT-4014	4
4	Wheel - Geared (Except Patented Track) For Patented Track Only	SBT-4015	SST-4015	4	SBT-4016	SBT-4016	4
		SBT-4017	SBT-4017	4	--	--	--
5	Ring - Retaining	SBT-4018	SBT-4018	4	SBT-4019	SBT-4019	4
6	Pinion - Motor	SBT-4020	SBT-4020	2	SBT-4020	SBT-4020	2
7	Key - Motor Pinion	SBT-4021	SBT-4021	2	SBT-4021	SBT-4021	2
8	Ring - Retaining	SBT-4022	SBT-4022	4	SBT-4022	SBT-4022	4
9	Screw - Hex Cap	SBT-4023	SBT-4023	8	SBT-4024	SBT-4024	8
10	Nut - Self-locking	SBT-4025	SBT-4025	8	SBT-4025	SBT-4025	8
11	Nut - Hex Jam	SBT-4026	SBT-4027	4	SBT-4028	SBT-4028	4
12	Lockwasher	SBT-4029	SBT-4030	4	SST-4031	SBT-4031	4
13	Washer - Spacer	SBT-4032	SBT-4033	40	SBT-4034	SBT-4034	44



12737

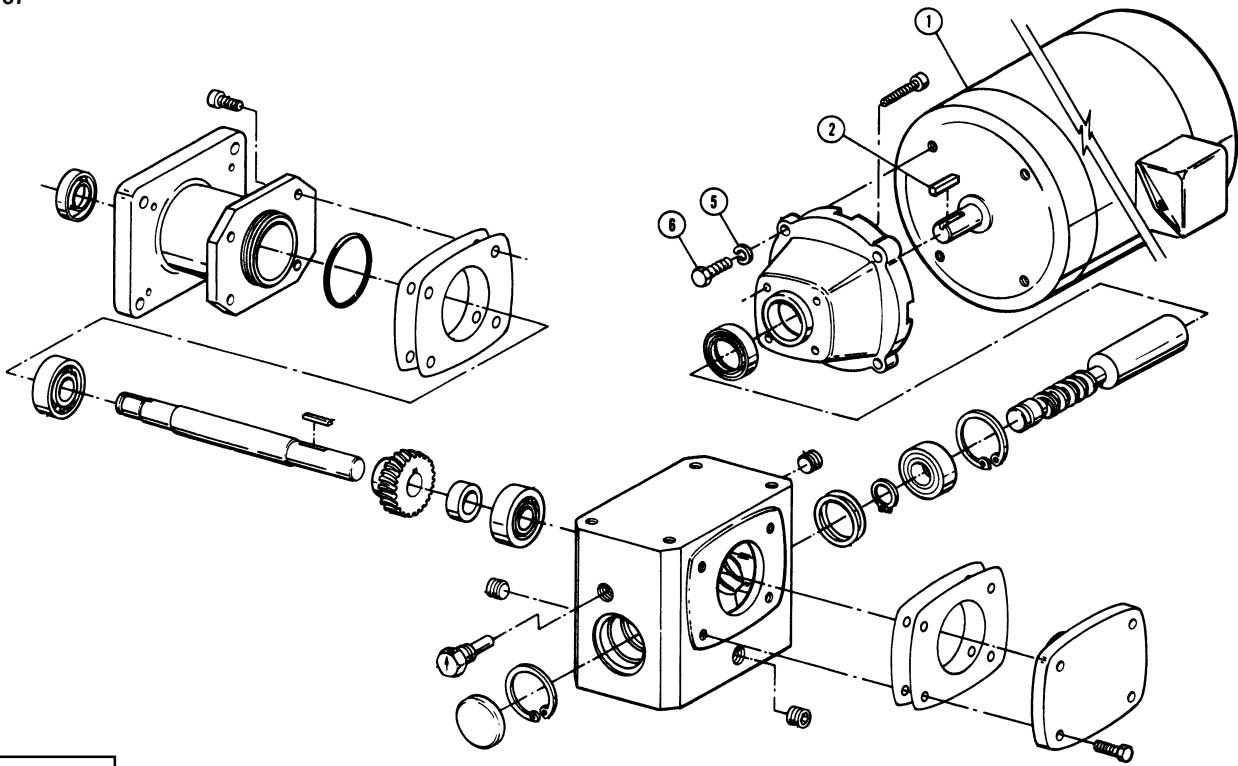

439509-xx  
602005-03-E

**Figure 11. Motor and Gearbox Assembly  
(3-1/8" & 5" c/c Pins)**

**Notice:** Five types of motor and gearbox assemblies have been used for trolleys with 3-1/8" & 5" c/c. When ordering replacement gearbox for 439076-xx gearbox, order new gearbox and motor.

**Ordering Instructions:** Furnish complete data from motor and gearbox nameplates with parts order. Replacement parts cannot be provided without this information.

Ref. No.	Part Number	Description	Qty. Req'd
	SBT-4800	Motor and Gearbox Assembly - Complete	
1	SBT-4801	Motor (Includes Ref. No.2)	1
2	SBT-4802	Key - Motor (1/8 x 1/8 x 3/4)	1
	SBT-4803	Gearbox Assembly - Complete	1
5	SBT-4806	Lockwasher (3/8)	4
6	SBT-4807	Bolt - Hex Head (3/8 - 16 x 1)	4

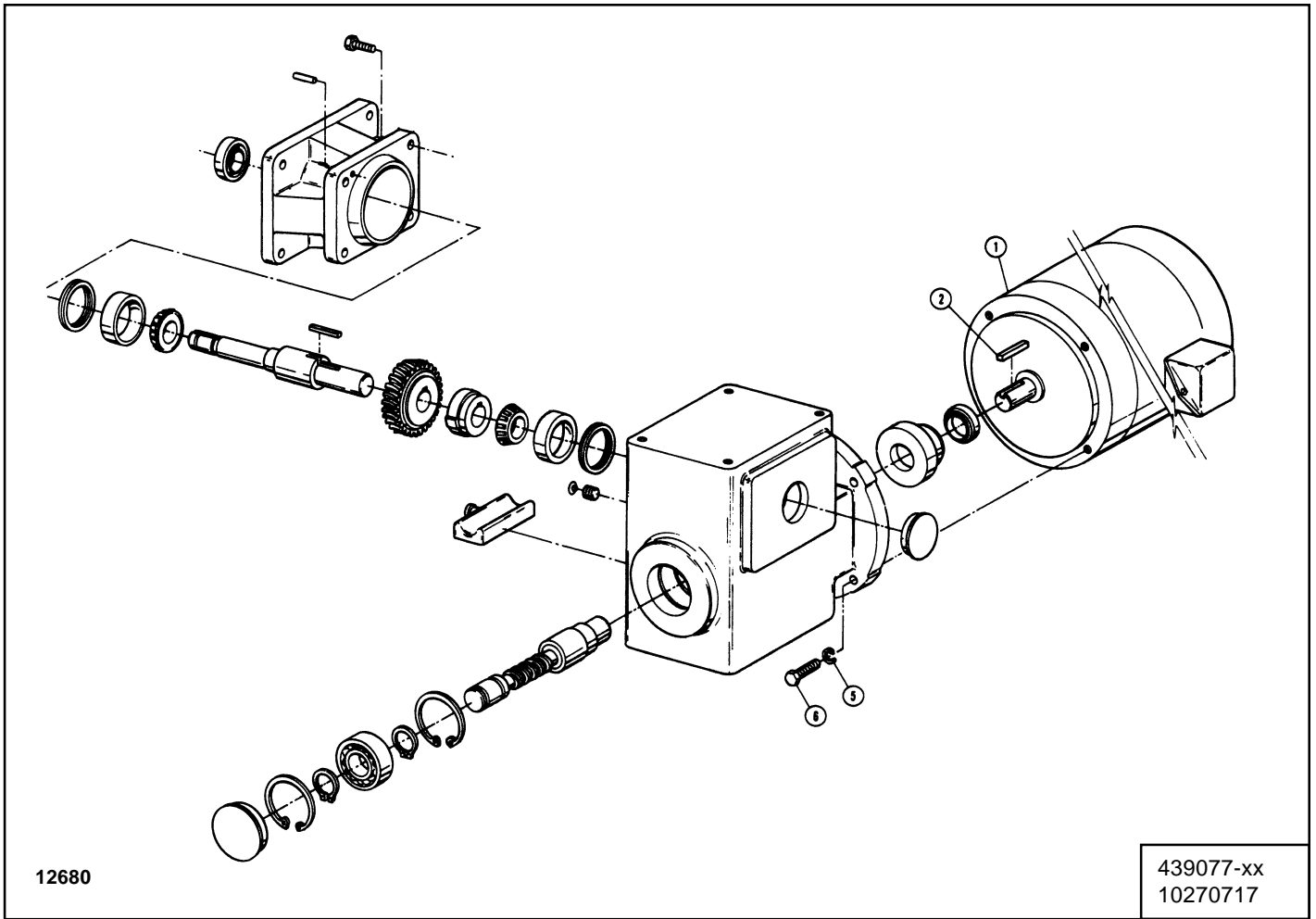

**Figure 12. Motor and Gearbox Assembly  
(6", 9" & 16" c/c Pins)**

**Ordering Instructions:** Furnish complete data from motor and gearbox nameplates with parts order.  
Replacement parts cannot be provided without this information.

Ref. No.	Part Number	Description	Qty. Req'd
	SBT-4200	Motor and Gearbox Assembly - Complete	1
1	SBT-4201	Motor (Includes Ref. No.2)	1
2	SBT-4202	Key - Motor (3/16 x 3/16 x 1-1/4)	1
	SBT-4203	Gearbox Assembly - Complete	1
5	SBT-4206	Lockwasher (3/8)	4
6	SBT-4207	Bolt- Hex Head (3/8 - 16 x 7/8)	4

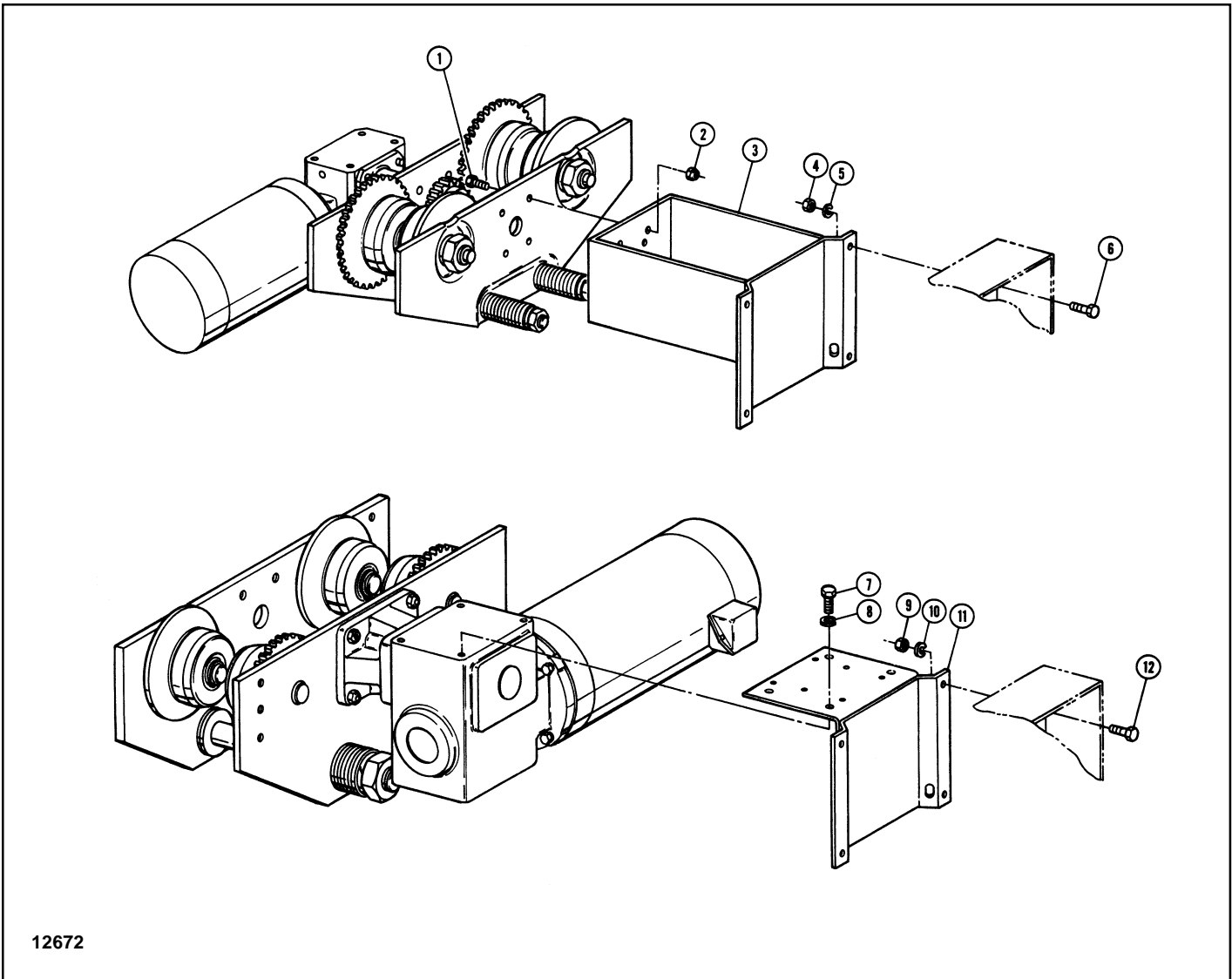
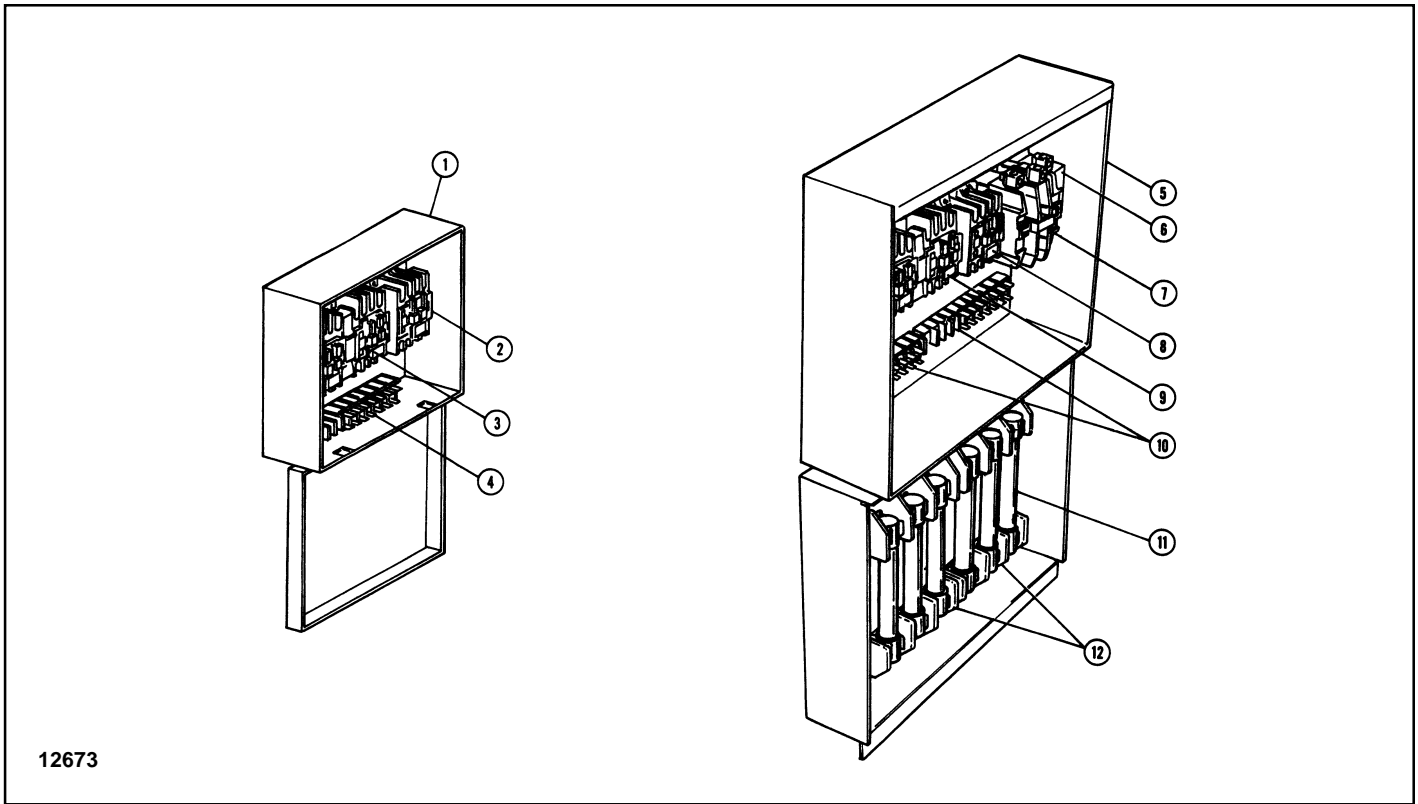

Figure 13. Electrical Enclosure Mountings

Ref. No.	Part Number	Description	Qty. Req'd
		For Trolleys with 3-1/8" and 5" c/c Pins:	
1	SBT-4300	Screw - Hex Cap	4
2	SBT-4301	Nut - Self-locking	4
3	SBT-4302	Mounting Bracket - Enclosure	1
4	SBT-4303	Nut - Hex	4
5	SBT-4304	Lockwasher	4
6	SBT-4305	Bolt - Hex Head	4
		For Trolleys with 6", 9" and 16" c/c Pins:	
7	SST-4306	Bolt - Hex Head	4
8	SBT-4307	Lockwasher	4
9	SBT-4303	Nut - Hex	4
10	SBT-4304	Lockwasher	4
11	SBT-4308	Mounting Bracket - Enclosure	1
12	SBT-4305	Bolt - Hex Head	4



12673

Figure 14. Electrical Enclosures

Ref. No.	Part Number	Description	Qty. Req'd
1	SBT-4400	Standard Enclosure: Enclosure - Electrical	1
2	SBT-4401	Contactors - Accelerating (For 2 Speeds Only)	1
3	SBT-4402	Contactors - Reversing	1
4	SBT-4403	Board - Terminal	1
5	SBT-4404	Enclosure For Options* Enclosure - Electrical	1
6		Transformer	
	SBT-4405	208/115 Volt	1
	SBT-4406	230/115 Volt or 460/115 Volt	1
	SBT-4407	575/115 Volt	1
7	SBT-4408	Contactors - Mainline	1
8	SBT-4401	Contactors - Accelerating	1
9	SBT-4402	Contactors - Reversing	1
10	SBT-4403	Board - Terminal	2
11		Fuses	
	SBT-4409	3 Amp, 250 Volt	As Req'd.
	SBT-4410	3 Amp, 600 Volt	As Req'd.
	SBT-4411	6 Amp, 250 Volt	As Req'd.
	SBT-4412	6 Amp, 600 Volt	As Req'd.
	SBT-4413	10 Amp, 250 Volt	As Req'd.
	SBT-4414	10 Amp, 600 Volt	As Req'd.
	SBT-4415	15 Amp, 250 Volt	As Req'd.
	SBT-4416	15 Amp, 600 Volt	As Req'd.
	SBT-4417	20 Amp, 250 Volt	As Req'd.
	SBT-4418	20 Amp, 600 Volt	As Req'd.
	SBT-4419	25 Amp, 250 Volt	As Req'd.

\*Components shown for maximum possible number of options. Any specific trolley may require only some of the shown components.

(Continued on Next Page)







Figure 15. Push Button Station and Conductor Cable Assembly (Continued).

Ref. No.	Part Number	Description	Qty. Req'd
	SBT-4512	For 7 Conductor Cable	1
	SBT-4513	For 8 and 10 Conductor Cable	1
	SBT-4514	For 12 Conductor Cable	1
7	SBT-4515	Cable - Strain *	1
8	SBT-4516	Sleeve - Pressure	1
	SBT-4517	Push Button Station Assembly - 4 Buttons (includes Ref. Nos. 9 thru 24)	1
	SBT-4518	Push Button Station Assembly - 6 Buttons (Includes Ref. Nos. 9 thru 24)	1
	SBT-4519	Enclosure Assembly - 4 Buttons (Includes Ref. Nos. 9 thru 21)	1
	SBT-4520	Enclosure Assembly - 6 Buttons (Includes Ref. Nos. 9 thru 21)	1
9		Clamp - Conductor	1
10		Screw - Slotted Head	2
11		Lockwasher	2
12		Support - Strain Cable	1
13	SBT-4525	Sleeve - Conductor	1
14		Nut - Hex	2
15	* *	Screw - Slotted Head	2
16	* *	Clamp - Conductor	1
17	* *	Enclosure Body	1
18	* *	Enclosure Front	1
19	* *	Enclosure Rear	1
20	* *	Screw - Slotted Head	
		4 Button Station	4
		6 Button Station	6
21	* *	Lockwasher	
		4 Button Station	4
		6 Button Station	6
22	SBT-4527	Block - Contact	
		4 Button Station	4
		6 Button Station	6
23	SBT-4528	Push Button Assembly	
		4 Button Station	4
		6 Button Station	6
24		Nameplate	
	SBT-4529	Up	1
	SBT-4530	Down	1
	SBT-4531	Right	1
	SBT-4532	Left	1
	SBT-4533	Start	1
	SBT-4534	Stop	1
25	SBT-4535	Operator Warning Label	1

\* Specify length required.

\*\* Not available separately. Order Enclosure Assembly.

### Notes

---



---



---



---



---



---



---



---



---



---

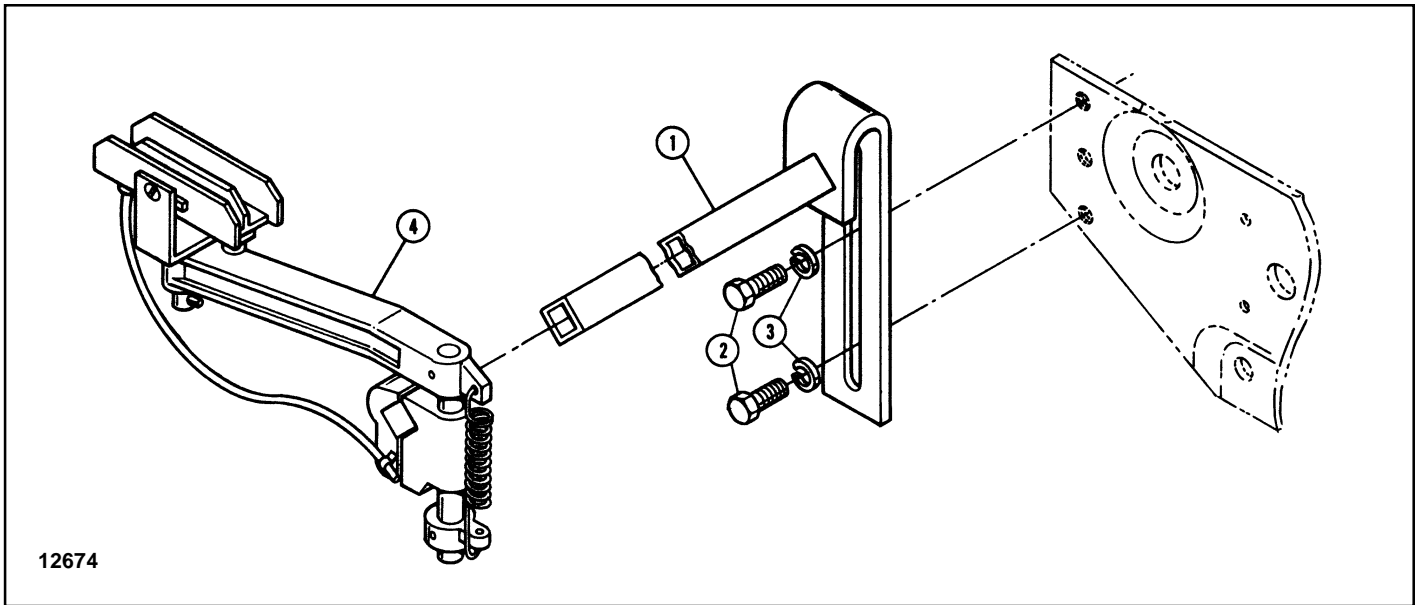

Figure 16. Current Collectors

Ref. No.	Part Number	Description	Qty. Req'd
		Collectors on One Side-of Trolley Only:	
1	SBT-4600	Bracket - Collector	1
2	SBT-4601	Bolt - Hex Head	2
3	SBT-4602	Lockwasher	2
4	SBT-4603	Collector	As Req'd.
		Collectors on Both Sides of Trolley:	
1	SBT-4600	Bracket - Collector	2
2	SBT-4601	Bolt- Hex Head	4
3	SBT-4602	Lockwasher	4
4	SBT-4603	Collector	As Req'd.

**Ballast Resistors (Optional) No Illustration**

Supply Voltage and Trolley Motor Horsepower	Resistor Assembly (Including Enclosure)		Resistor	
	Part Number	Qty. Req'd.	Part Number	Qty. Req'd.
208-230 Volt				
1/6 HP	SBT-4700	1	SBT-4701	3
1/4 and (2) 1/6 HP	SBT-4702	1	SBT-4703	3
1/2, 3/4, 1, (2) 1/4 and (2) 1/2 HP	SBT-4704	1	SBT-4705	3
460 Volt				
1/6 HP	SBT-4706	1	SBT-4707	3
1/4 and (2) 1/6 HP	SBT-4708	1	SBT-4709	3
1/2, 3/4, 1 and (2) 1/4 HP	SBT-4700	1	SBT-4701	3
(2) 1/2 HP	SBT-4702	1	SBT-4703	3
575 Volt				
1/6, 1/4 and (2) 1/6 HP	SBT-4706	1	SBT-4707	3
1/2 and (2) 1/4 HP	SBT-4708	1	SBT-4709	3
3/4 and (2) 1/2 HP	SBT-4700	1	SBT-4701	3

## Recommended Spare Parts for Your Shaw-Box Motor Driven Trolley

Certain parts of your hoist will, in time, require replacement under normal wear conditions. It is suggested that the following parts be purchased for your hoist as spares for future use.

Motor Pinion  
One Set of Wheel Bearings  
One Set of Wheels  
One Contactor  
One Set of Fuses (If Required)

**Note:** When ordering parts always furnish Model and Catalog Number and Motor Nameplate Data of trolley on which the parts are to be used.

Parts for your trolley are available from your local authorized **Shaw-Box** repair station. For the location of your nearest repair station, write:

### **IN USA**

#### **Yale•Lift-Tech**

P.O. Box 769  
Muskegon, MI 49443-0769

Phone: **800 742-9269**

Fax: **800 742-9270**

# WARRANTY

## **WARRANTY AND LIMITATION OF REMEDY AND LIABILITY**

A. Seller warrants that its products and parts, when shipped, and its work (including installation, construction and start-up), when performed, will meet applicable specifications, will be of good quality and will be free from defects in material and workmanship. All claims for defective products or parts under this warranty must be made in writing immediately upon discovery and in any event, within one (1) year from shipment of the applicable item unless Seller specifically assumes installation, construction or start-up responsibility. All claims for defective products or parts when Seller specifically assumes installation, construction or start-up responsibility and all claims for defective work must be made in writing immediately upon discovery and in any event, within one (1) year from completion of the applicable work by Seller, provided; however, all claims for defective products and parts made in writing no later than eighteen (18) months after shipment. Defective items must be held for Seller's inspection and returned to the original f.o.b. point upon request. THE 'FOREGOING IS EXPRESSLY IN LIEU OF ALL OTHER WARRANTIES WHATSOEVER, EXPRESS, IMPLIED AND STATUTORY, INCLUDING, WITHOUT LIMITATION, THE IMPLIED WARRANTIES OF MERCHANTABILITY AND FITNESS.

B. Upon Buyer's submission of a claim as provided above and its substantiation, Seller shall at its option either (i) repair or replace its product, part or work at either the original f.o.b. point of delivery or at Seller's authorized service station nearest Buyer or (ii) refund an equitable portion of the purchase price.

C. This warranty is contingent upon Buyer's proper maintenance and care of Seller's products, and does not extend to normal wear and tear. Seller reserves the right to void warranty in event of Buyer's use of inappropriate materials in the course of repair or maintenance, or if Seller's products have been dismantled prior to submission to Seller for warranty inspection.

D. The foregoing is Seller's only obligation and Buyer's exclusive remedy for breach of warranty and is Buyer's exclusive remedy hereunder by way of breach of contract, tort, strict liability or otherwise. In no event shall Buyer be entitled to or Seller liable for incidental or consequential damages. Any action for breach of this agreement must be commenced within one (1) year after the cause of action has accrued.

**SHAW-BOX®**