

# Conductor Bar Manual

## Safe-Lec 2 “V” Contact Bar

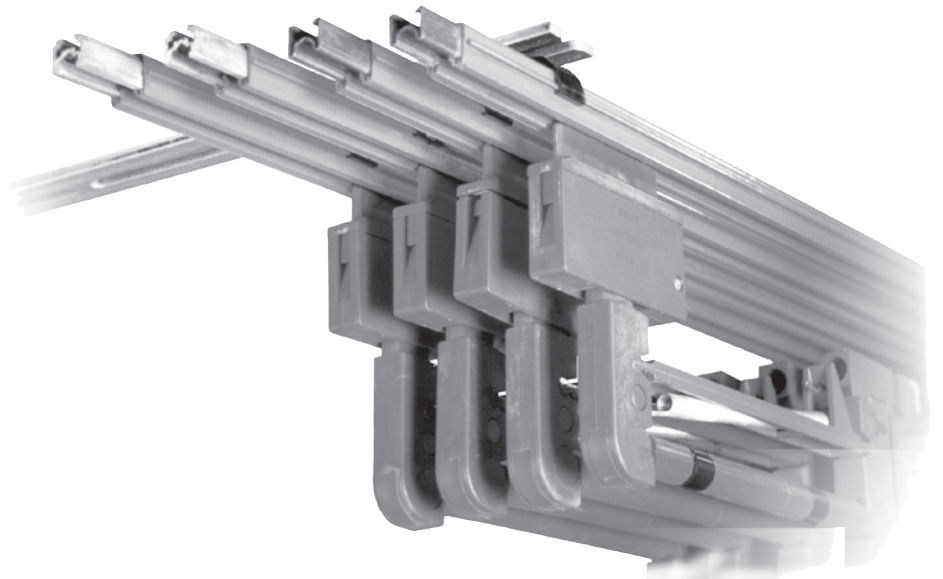

# Conductix Incorporated

The technical data and images which appear in this manual are for informational purposes only. **NO WARRANTIES, EXPRESS OR IMPLIED, INCLUDING WARRANTIES OF MERCHANTABILITY OR FITNESS FOR A PARTICULAR PURPOSE, ARE CREATED BY THE DESCRIPTIONS AND DEPICTIONS OF THE PRODUCTS SHOWN IN THIS MANUAL.** Conductix makes no warranty (and assumes no liability) as to function of equipment or operation of systems built according to customer design or of the ability of any of its products to interface, operate or function with any portions of customer systems not provided by Conductix.

Seller agrees to repair or exchange the goods sold hereunder necessitated by reason of defective workmanship and material discovered and reported to Seller within one year after shipment of such goods to Buyer.

Except where the nature of the defect is such that it is appropriate, in Seller's judgment, to effect repairs on site, Seller's obligation hereunder to remedy defects shall be limited to repairing or replacing (at Seller's option) FOB point of original shipment by Seller, any part returned to Seller at the risk and cost of Buyer. Defective parts replaced by Seller shall become the property of Seller.

Seller shall only be obligated to make such repair or replacement if the goods have been used by Buyer only in service recommended by Seller and altered only as authorized by Seller. Seller is not responsible for defects which arise from improper installation, neglect, or improper use or from normal wear and tear.

Additionally, Seller's obligation shall be limited by the manufacturer's warranty (and is not further warranted by Seller) for all parts procured from others according to published data, specifications or performance information not designed by or for Seller.

Seller further agrees to replace or at Seller's option to provide a refund of the sales price of any goods that do not conform to applicable specifications or which differ from that agreed to be supplied which non-conformity is discovered and forthwith reported to Seller within thirty (30) days after shipment to the Buyer. Seller's obligation to replace or refund the purchase price for non-conforming goods shall arise once Buyer returns such goods FOB point of original shipment by Seller at the risk and cost of Buyer. Goods replaced by Seller shall become the property of Seller.

There is no guarantee or warranty as to anything made or sold by Seller, or any services performed, except as to title and freedom from encumbrances and, except as herein expressly stated and particularly, and without limiting the foregoing, **there is no guarantee or warranty, express or implied, of merchantability or of fitness for any particular purpose or against claim of infringement or the like.**

Seller makes no warranty (and assumes no liability) as to function of equipment or operation of systems built to Buyer's design or of the ability of any goods to interface, operate or function with any portions of Buyer's system not provided by Seller.

Seller's liability on any claim, whether in contract, tort (including negligence), or otherwise, for any loss or damage arising out of, connected with, or resulting from the manufacture, sale, delivery, resale, repair, replacement or use of any products or services shall in no case exceed the price paid for the product or services or any part thereof which give rise to the claim. In no event shall Seller be liable for consequential, special, incidental or other damages, nor shall Seller be liable in respect of personal injury or damage to property not the subject matter hereof unless attributable to gross misconduct of Seller, which shall mean an act or omission by Seller demonstrating reckless disregard of the foreseeable consequences thereof.

Seller is not responsible for incorrect choice of models or where products are used in excess of their rated and recommended capacities and design functions or under abnormal conditions. Seller assumes no liability for loss of time, damage or injuries to property or persons resulting from the use of Seller's products. Buyer shall hold Seller harmless from all liability, claims, suits and expenses in connection with loss or damage resulting from operation of products or utilization of services, respectively, of Seller and shall defend any suit or action which might arise there from in Buyer's name - provided that Seller shall have the right to elect to defend any such suit or action for the account of Buyer. The foregoing shall be the exclusive remedies of the Buyer and all persons and entitles claiming through the Buyer.

- 1.0 Conductor System Nomenclature**
- 2.0 Typical Layout of a 3 Phase Plus Ground Conductor System**
- 3.0 Environmental Considerations**
- 4.0 Recommended Installation Tools and Equipment**
- 5.0 General Assembly Instructions**
- 6.0 Support Bracket Installation**
- 7.0 Mounting Details of Four Bar Conductor Hanger**
- 8.0 Installing Conductors into Hanger**
- 9.0 Anchor Hanger Support Assembly**
- 10.0 Assembly of Bolted Galvanized Steel and Copper Joints**
- 11.0 Assembly of Bolted Aluminum Joint**
- 12.0 Assembly of Joint Cover onto Bolted Joint Assemblies**
- 13.0 Assembly of End Cap onto Galvanized Steel and Copper Conductor Bars**
- 14.0 Assembly of End Cap onto Aluminum/Stainless Steel Conductor Bars**
- 15.0 Expansion Section Assembly**
- 16.0 Expansion Gap Setting for Conductor Bars with PVC Cover**
- 17.0 Assembly of End Power feed**
- 18.0 Assembly of Low Amp Joint Power feed**
- 19.0 Assembly of Power feed and Cover**
- 20.0 Assembly Instructions for Power feed and Joint Cover**
- 21.0 Terminal Chart (for guidelines only)**
- 22.0 Mounting Details for DI Collector**
- 23.0 Mounted Details for SI Collector**
- 24.0 Customer Supplied Cable Installation**
- 25.0 250 Amp Collector**
- 26.0 Assembly of Transfer Cap**
- 27.0 Transfer Cap Mounting Details**
- 28.0 Assembly of Isolation Sections**
- 29.0 System Maintenance and Installation Notes**
- 30.0 Replacement of DI Collector Contact Shoe and Shoe Holder**
- 31.0 Assembly Instructions for Single, Two, Three and Four Way Pickup Guide**
- 32.0 Diagram Showing Hanger Centers**
- 33.0 Conductor Bar De-Rating Chart**
- 34.0 Contact Information**

# 1.0 Conductor System Nomenclature

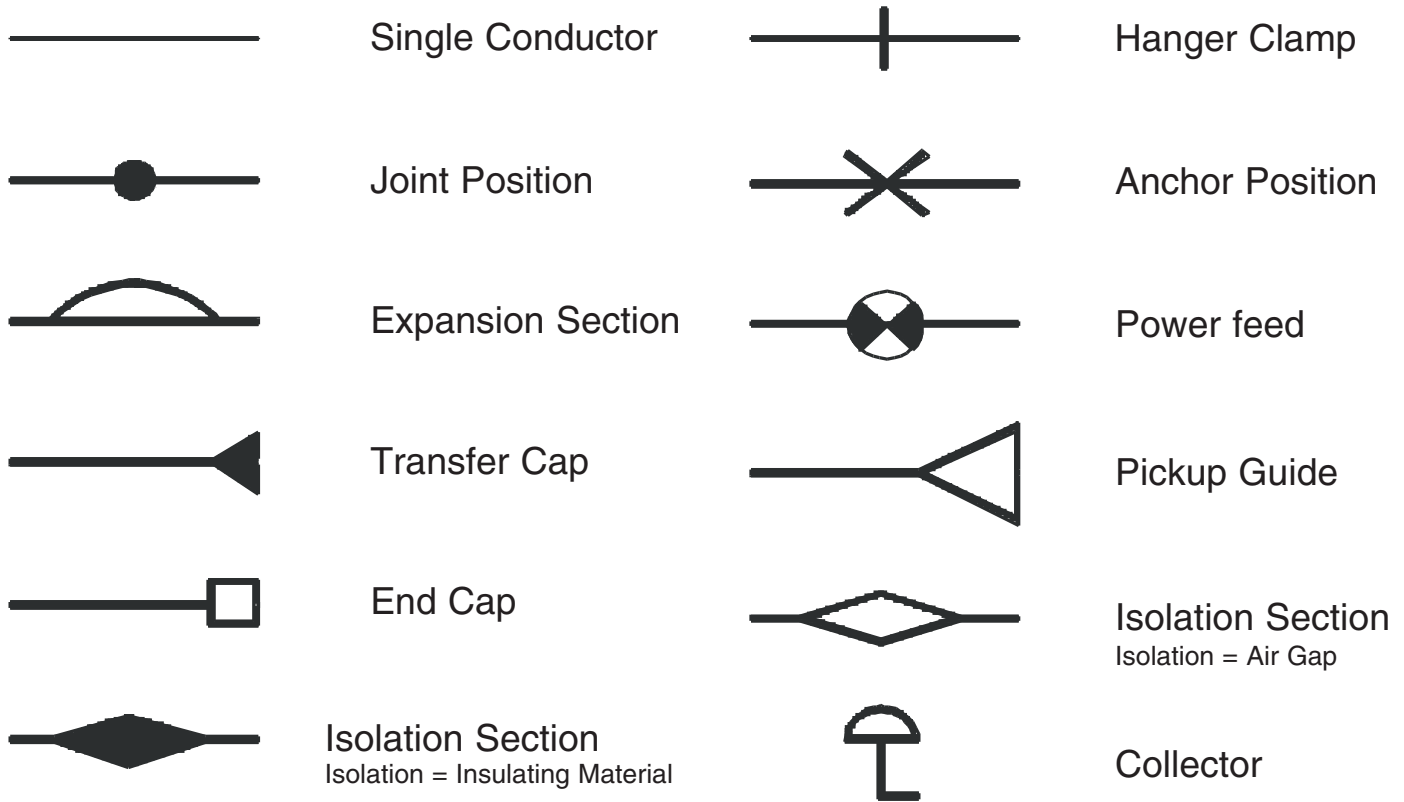

# 2.0 Typical Layout of a 3 Phase Plus Ground Conductor System

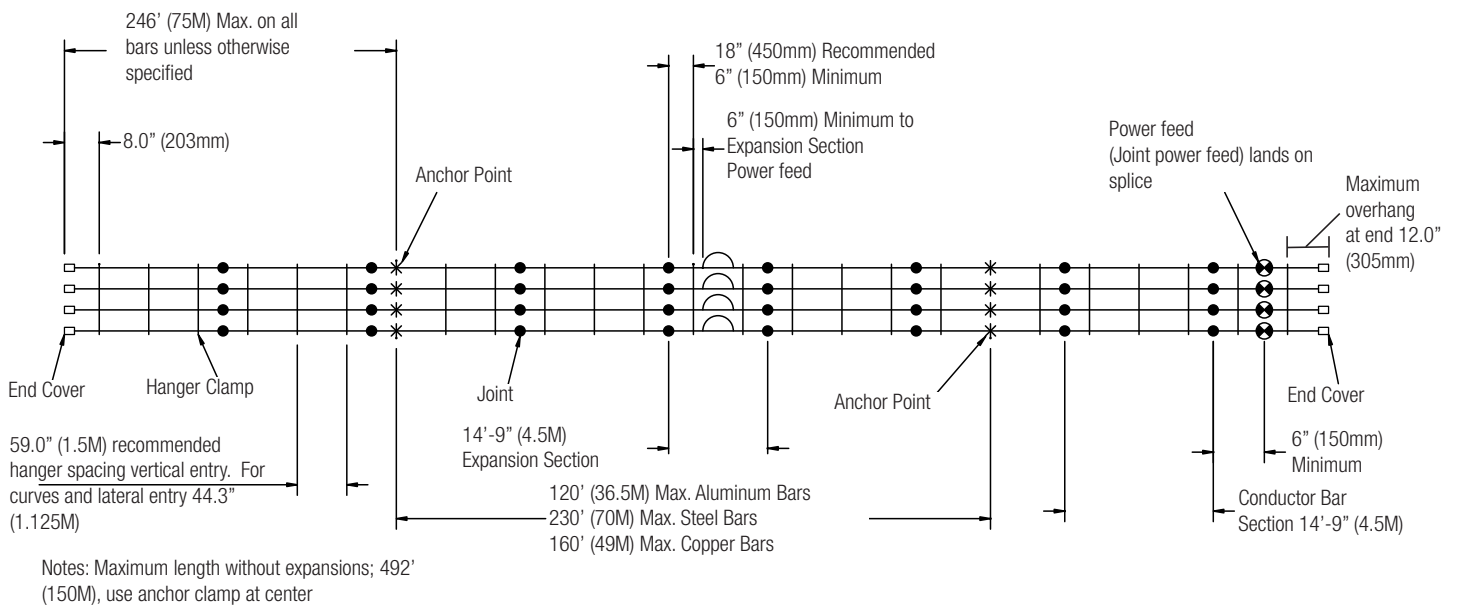

Maximum Runway Without Expansions = 492"

**ATTENTION:** CURVED BAR TO BE  
FACTORY BENT ONLY!

Dimensions are in mm. (inches)

**NOTE:** Maximum Recommended Hanger Spacing:  
1.125 Meters (44")  
On all Lateral Mount Systems  
Curved Systems (curved section only)

## 3.0 Environmental Considerations

- Standard Cover (PVC) is suitable up to 160°
- Medium Heat Cover (Poly carbonate) is suitable up to 250°
- The following acidic or corrosive environments require the use of stainless steel hangers
  - Hydrochloric Acid
  - Hydrofluoric Acid
  - Sodium Hydrochloride
  - Ammonium Chloride
  - Chlorine Bleach
  - Chloride Ions
  - Fluoride Ions

- Do not use standard (black) or medium heat (red) hangers in these environments

## 4.0 Recommended Installation Tools and Equipment

1. Man lift or platform lift for access to the installation location (if required)
2. Sharp knife - to cut power feed grommets
3. Straight blade screwdriver - for securing feed cable to collectors and replacing collector shoes
4. Steel rule or tape measure - to position collectors during installation
5. Wire/cable stripper
6. Cable lug crimping tool (see list of lugs on page 16)
7. Cordless drill with socket adapter (1/4" or 3/8" drive)
8. Deep sockets for cordless drill
  - a. 8mm - for anchor cross bolts
  - b. 10mm - for splices, isolation sections, and power feeds
  - c. 13mm - for mounting hangers, collectors, anchors and transfer caps.
9. Torque wrench for sockets listed above
10. Open/box end wrenches (use ratcheting box-end wrenches if you have them)
  - a. 8mm
  - b. 10mm
  - c. 13mm
11. Hacksaw
12. Flat file and/or rat tail file to remove burrs on field cut conductors
13. Pliers

## 5.0 General Assembly Instructions

**WARNING: Always lock out/tag out all electrical power before starting work.**

This manual provides detailed instructions in the general order of system installation.

System installation consists of 5 phases:

1. Identifying and organizing the materials
2. Installation of brackets along the runway
3. Pre-install assemblies on the ground
4. Installation of hangers and conductors and final assembly along the runway
5. Installation and alignment of collectors on the crane

### 1. Identify and organize your materials

Check the pack list against the items received. Parts are labeled for your convenience. Review your specific installation layout drawing (if provided) or the typical layout diagram on page 4 to become familiar with component location on the system. Note where the anchors, expansions, power feeds and other assemblies will be located along the runway. Read through these instructions before starting work.

### 2. Install your brackets

Per the diagram on page 7. Keep them as level and evenly spaced as possible. You may install the hangers on the brackets before or after they are mounted along the runway.

### 3. Assemble as much as possible on the ground

It's faster, easier, safer and more convenient should you drop something.

- a. Conductor Bar and Expansion Sections will come from the factory with one splice pre-installed.
- b. Install end caps on the end conductors, keeping these separated from the main runway conductors.
- c. Install isolation splices (if included) on the ends of the conductors in accordance with the installation layout drawing and the instructions on page 19.
- d. Install transfer caps on the conductor ends (if included) per page 18 and 19.

### 4. Final installation along the runway

(will most likely be accomplished from a lift or work platform)

- a. **Ensure the power is locked out/tagged out!**
- b. Install the hangers, per instructions on page 8
- c. Roll adjacent conductors in the hangers (per 3 step process) as shown on page 8. Conductix recommends the first accessible conductor being the ground conductor.
- d. Move down the runway, install the next inboard conductor and join it to the corresponding conductor installed in step 4c. Install the splice cover. Keep the splice assemblies 6-12" from the hanger brackets to allow for conductor movement from expansion. Repeat for the remaining phases and ground conductors.
- e. When you get to where the expansion assemblies are to be installed, refer to the instructions on page 12. Be sure to divide the total expansion gap distance (from chart) between the two air gap locations in the expansion assembly.
- f. Proceed with system installation, ensuring anchors are positioned the correct distance from the expansions and that they are tightened to the correct torque.
- g. If a conductor must be cut to a specific length, ensure that the cut end is properly de-burred. The conductor cover is always shorter than the bar length, the proper cover length is 66mm (2.60") shorter than bar length. (33mm / 1.30" on each end).
- h. When you run the feed cable to the power feed assembly, ensure the cables have sufficient free length and are flexible enough to enable movement of the conductor due to expansion. Locating the power feed as close as possible to the anchors minimizes this concern. Do not support the weight of the feed cables with the conductors.
- i. Install power feeds on conductor bars per layout and the instructions on page 14.

## 5.0 General Assembly Instructions

### 5. Collectors must be properly positioned and aligned to ensure safe, reliable operation.

- The collector mounting post must be 127mm (5.0") for 250 Amp. collectors, 102mm (4.0") for 100 Amp. DI collectors and 90mm (3.5") for 50 Amp. SI collectors, below the contact surface of the conductor and the arms level from end to end.
- Slide the collectors on the mounting staff. Ensure the mounting base of each collector is centered below the corresponding conductor. Ensure the collectors are evenly spaced. Tighten hardware to specifications and connect the supply cable to the collector per diagram on page 17.

#### REMEMBER

- Follow lockout/tagout procedures
- Keep accessories at least 6" from hanger brackets
- Follow all torque specifications
- Allow for movement of accessories due to expansion
- Connect only flexible power cables to power feed assemblies
- Keep collectors straight, level and aligned with conductors

## 6.0 Support Bracket Installation

- Locate and secure support brackets at the recommended spacing.  
(Note: Locate support brackets at a spacing that is divisible into the conductor bar lengths. This will always ensure that the joint positions do not interfere with the support brackets).
- Observe all alignment tolerances.  
Datum height  
Maximum allowable deviation from datum height + 5.0mm (+3/16").

#### FOR CONDUCTIX BRACKETS

Hanger support brackets come complete with all necessary mounting holes for easy installation of hangers via slide in slots or holes.

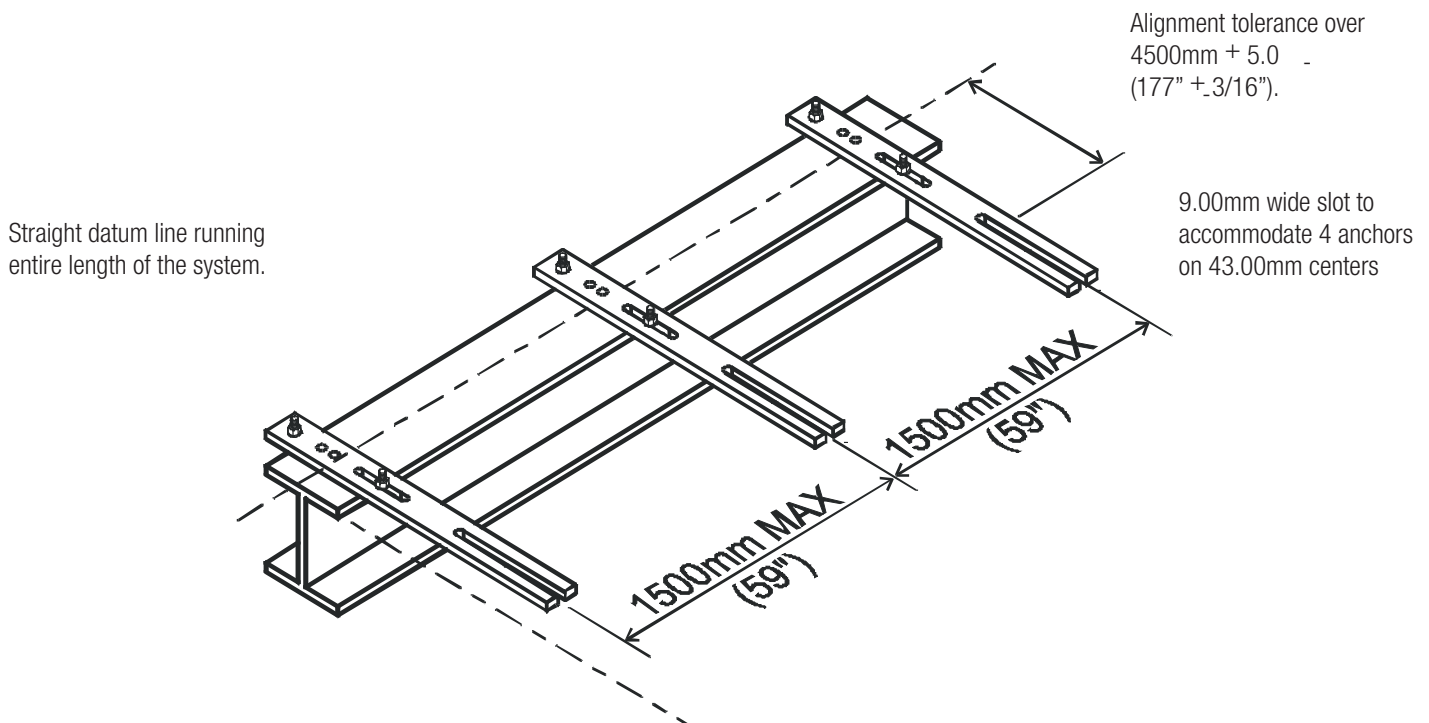

## 7.0 Mounting Details of Four Bar Conductor Hanger

For Indoor and Limited Outdoor use, P/N 310821

Note: For Lateral Mount - Consult Factory

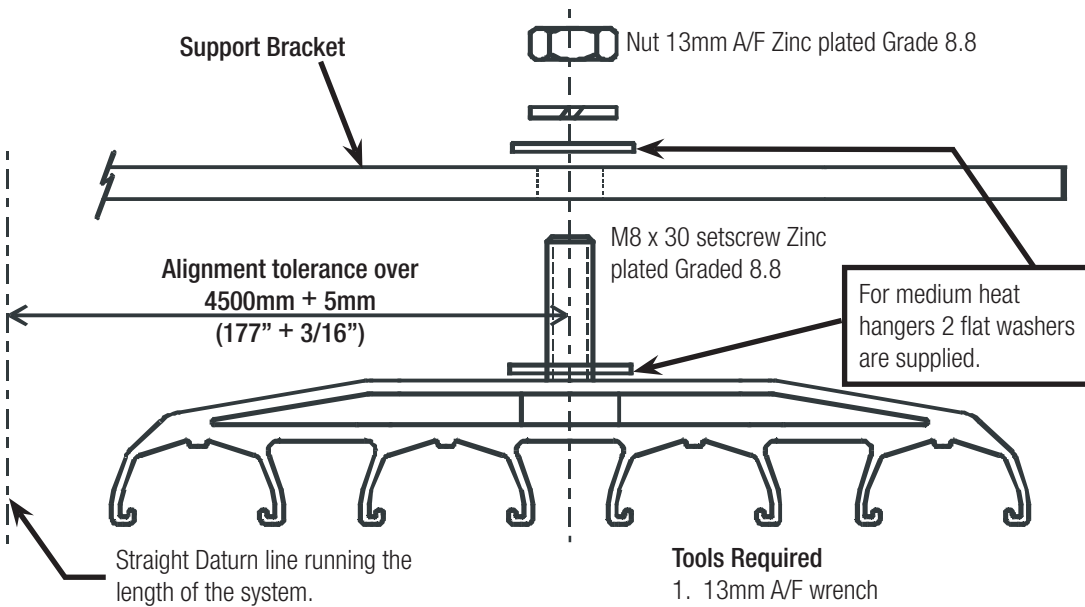

1. Remove nut, lock washer, and washer from hanger assembly. (The M8 bolt will stay in place inside the molding.)
2. Assemble as shown in the diagram ensuring the correct alignment is observed.
3. Finger tighten M8 nut.
4. Snap conductor bars into hangers.
5. Tighten M8 nut to Conductix recommended torque of 8 Nm (5-6 ft-lbs.)

**Tools Required**  
1. 13mm A/F wrench

**NOTE:** This hanger may be used outside when the bar system is covered and protected from the elements. If the bar system will be exposed to rain, snow, ice, fog etc., then a single pole insulated hanger must be used.

## 8.0 Installing Conductors into Hanger

P/N 310821

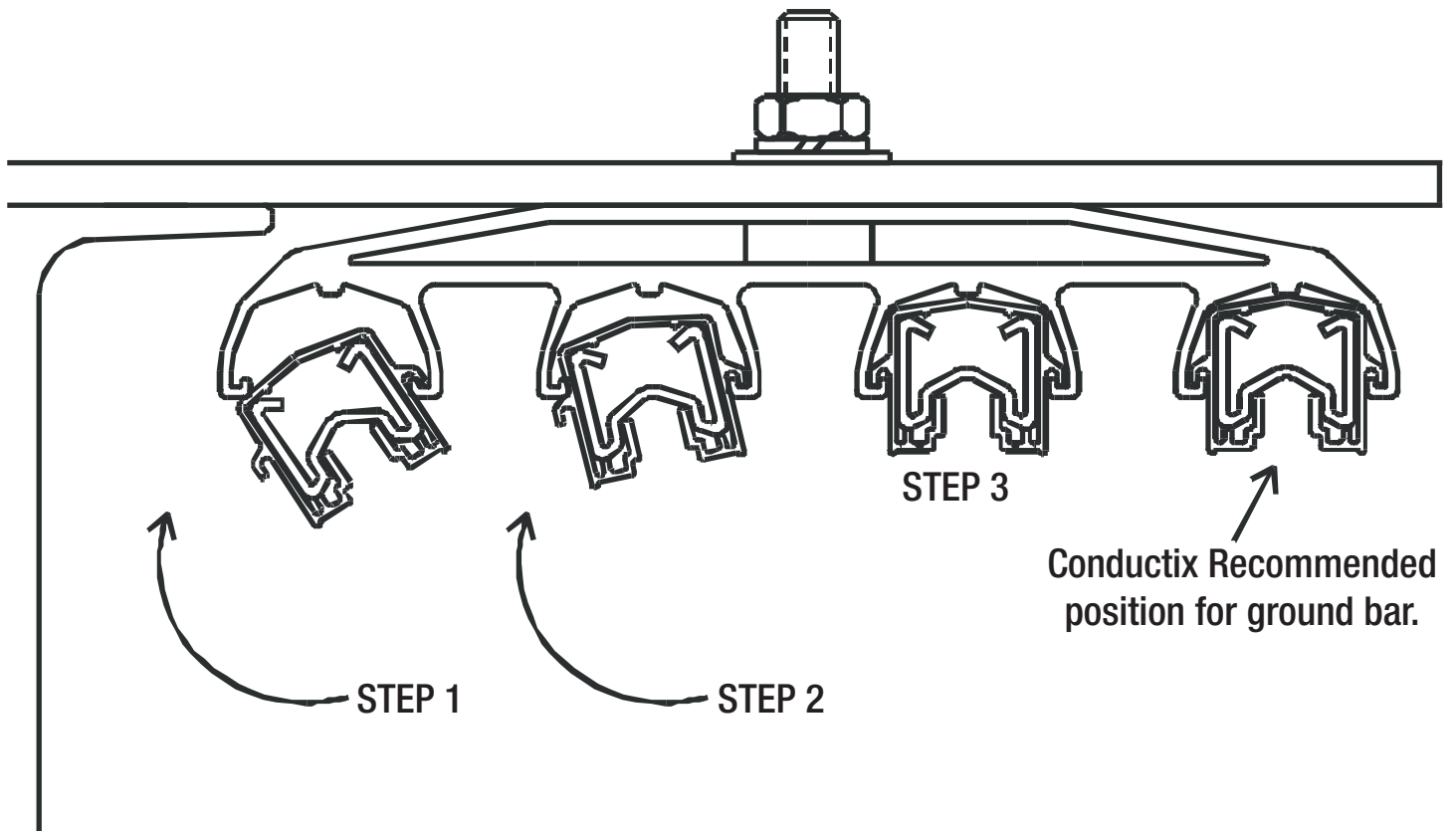



## 9.0 Anchor Hanger Support Assembly

P/N 310832

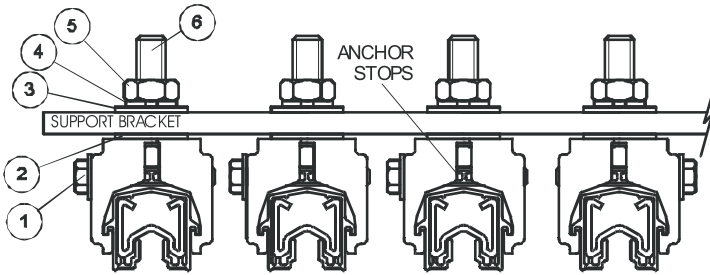

**Note:** For ease of access to clamping setscrews (item 1) install anchor hanger assemblies as shown above.

**Tools Required:**

13mm A/F open ended wrench.

8mm A/F open ended wrench.

Assembly of bolted Galvanized Steel and Copper Joint

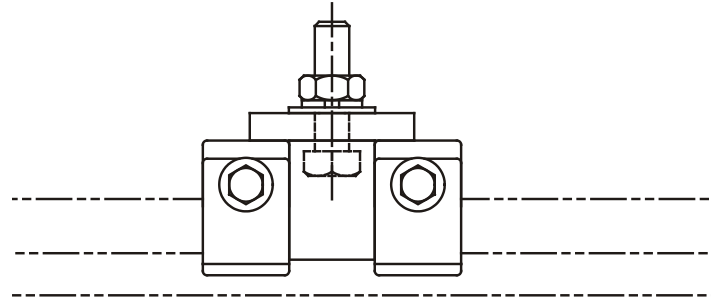

**Part No. 310831**

1. Remove items 3, 4 & 5 from assembly.
2. Assemble anchor over cover so this is free to slide.
3. Insert anchor hanger into support bracket.
4. Reassemble items 3, 4 & 5
5. Tighten item 1 until anchor stops meet. (check anchor is tight on cover)
6. Tighten item 5 to a torque of 8 Nm (5-6 ft. lbs.)

## 10.0 Assembly of Bolted Steel/Copper Joint

P/N 310872 & 310873

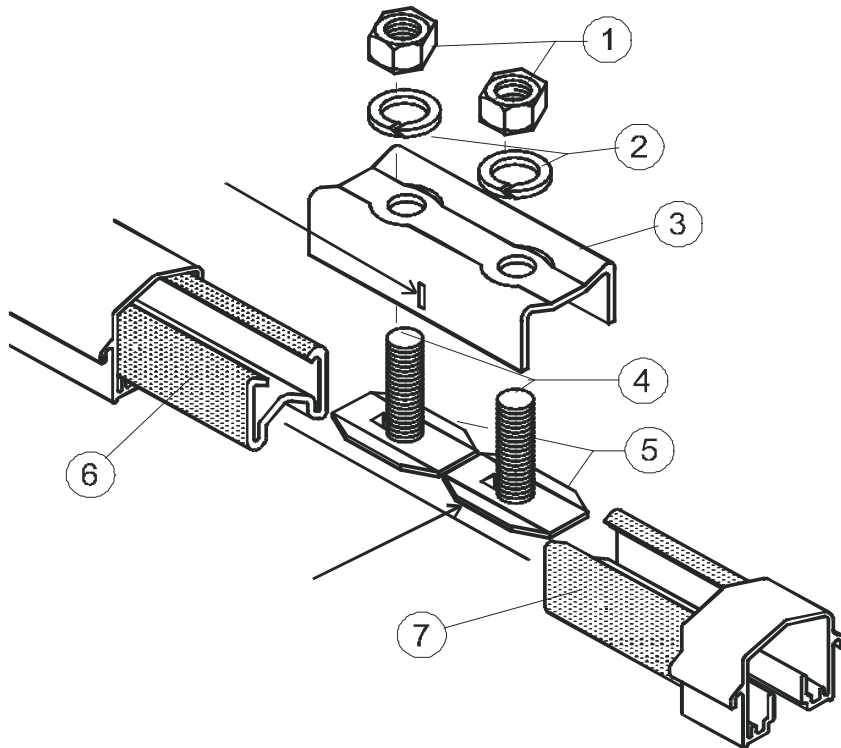

**Tools Required:** 10mm A/F open ended wrench

1. Fit item 4 into item 5. (Ensure tab captivates the head on the setscrew.)
2. Slide item 4 and Item 5 into Item 6 and 7 respectively.
3. Place item 3 over item 4, making sure alignment mark is in line with end faces of conductor bar.
4. Fit items 2 and 1 in the order shown.
5. Tighten item 1 to Conductix recommended torque of 8 Nm (5-6 ft-lbs).
6. Check that both faces of the conductor bar are touching each other and there is no gap exceeding 0.5mm (0.02") at the faces.
7. **NOTE:** if the conductor was field cut, file off all burrs on conductor ends before assembling splices.

## 11.0 Assembly of Bolted Aluminium Joint

### P/N 310874

**Tools Required:** 10mm A/F open ended wrench  
Electrical Joint Compound  
P/N 15629

1. Apply electrical joint compound to the faces shown.
2. Slide item 4 into item 5 and item 6 respectively.
3. Place items 3 over items 4.
4. Fit items 2 and 1 in order shown.
5. Tighten items 1 to a Conductix recommended torque of 8 Nm (5-6 ft-lbs).
6. Check that both faces of conductor bar are touching each other and that there is no gap exceeding 0.5mm (0.02") at the faces.
7. NOTE: If the conductor was field cut, file off all burrs on conductor ends before assembling splices. Exposed length of bar should be 33mm (1.3") per end.

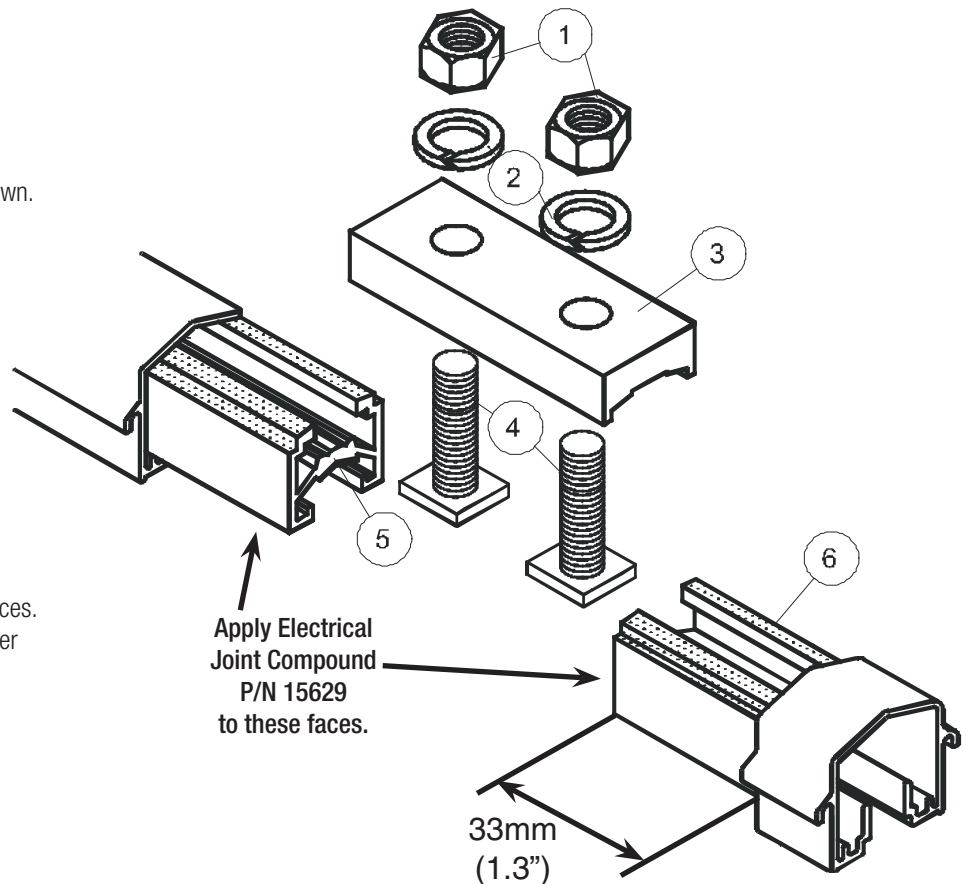

## 12.0 Assembly of Joint Cover onto Bolted Joint Assemblies

### P/N 310850 with P/N's 310872, 310873, 310874

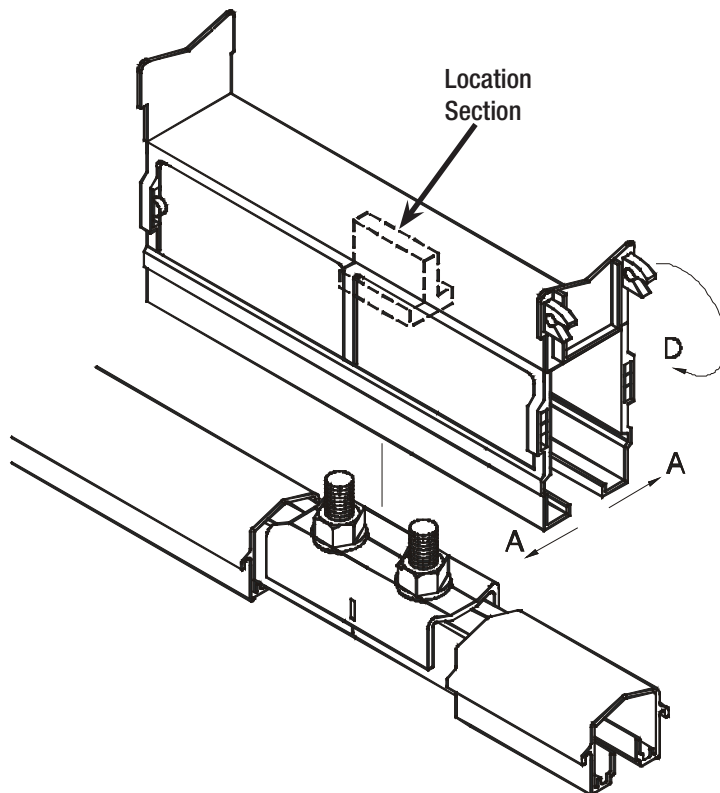

1. Spring legs out in the directions "A-A" as shown. (This is to ease the fitting of the joint cover over the conductor bar.)
2. Fit the joint cover over the bolted joint. Joint cover MUST NOT be opened up more than 45° on either side during the assembly over the joint. Ensure the "Location Section" sits between the two bolts.
3. Close the flaps in the direction "D". Ensure the flaps "click" home on both sides.

## 13.0 Assembly of End Cap onto Galv Steel and Copper Conductor Bars

P/N 310892

Tools Required: 10mm A/F open ended wrench

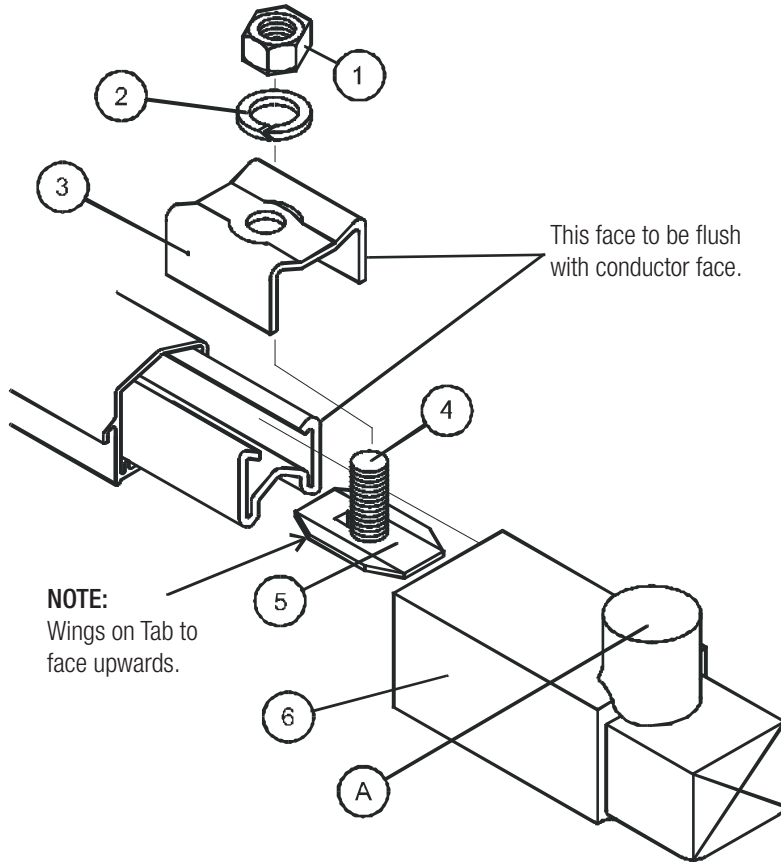

1. Place item 4 into item 5 so that the head of the setscrew is captivated within the tab of stainless steel washer.
2. Place assembly (4 & 5) into conductor bar.
3. Place items 3, 2, & 1 over assemblies 4 & 5 (Ensure item 3 is flush with conductor bar face.)
4. Tighten item 1 to a Conductix recommended torque of 8 Nm (5-6 ft-lbs).
5. Push item 6 over assembly (Ensure item 4 is located in point "A" on item 6).

## 14.0 Assembly of End Cap onto Aluminium/Stainless Steel Conductor Bars

P/N 310893

Tools Required: 10mm A/F open ended wrench

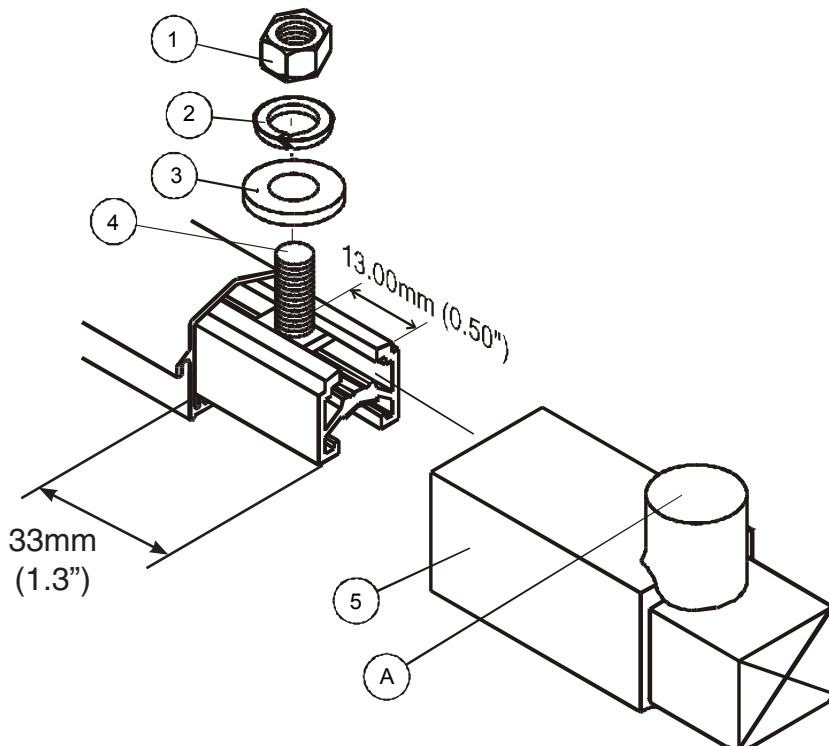

1. Mark conductor bar top surface 13mm (0.50") in from end face.
2. Place item 4 into conductor bar.
3. Ensure center line of setscrew item 4 is on the center line marked on the conductor surface.
4. Place item 3, 2 & 1 onto item 4 in the order shown.
5. Tighten item 1 to a Conductix recommended torque of 8 Nm (5-6 ft-lbs).
6. Push item 5 over assembly. (Ensure item 4 is located in point "A" on item 5).

# 15.0 Expansion Section Assembly

- The maximum allowable conductor system length without an Expansion Section is 150 meters (492')
  - \* Assuming a Maximum Temperature Range of 110° F
- The maximum distance between anchor points with an Expansion Section at mid-point is 75 meters (246')
- Set Expansion air gaps when installing assembly to appropriate gap setting for ambient temperature (see chart). The gap is adjusted by sliding the moving lengths of conductor in or out of the expansion assembly (Note: BOTH HALVES MUST BE SET EQUAL). Always allow sufficient time for the conductor bars to achieve ambient temperature before setting Expansion gap. All Expansion assemblies must be set at site, they are not pre-set before leaving the factory. Failure to set this part correctly could result in buckling of all conductors.

## EXPANSION AIR GAP SETTING FOR CONDUCTOR BARS WITH PVC COVER

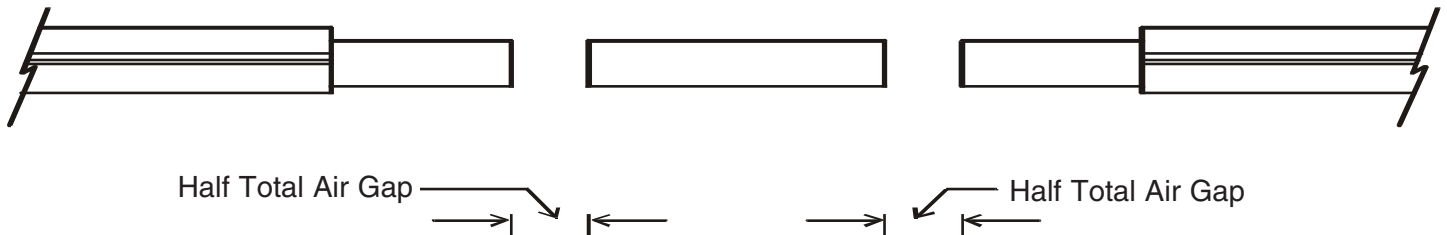

		ACTUAL SITE AMBIENT: °C (°F)																
		-25° (-13°)	-20° (-4°)	-15° (5°)	-10° (14°)	-5° (23°)	0° (32°)	5° (41°)	10° (50°)	15° (59°)	20° (68°)	25° (77°)	30° (86°)	35° (95°)	40° (104°)	45° (113°)	50° (122°)	55° (131°)
LOWEST POSSIBLE SITE AMBIENT °C (°F) [SEE NOTE]	25° (77°)											50 (1.97)	45 (1.77)	41 (1.61)	36 (1.42)	32 (1.26)	27 (1.06)	23 (0.91)
	20° (68°)										50 (1.97)	46 (1.81)	42 (1.65)	38 (1.50)	33 (1.30)	29 (1.14)	25 (0.98)	21 (0.83)
	15° (59°)									50 (1.97)	46 (1.81)	42 (1.65)	38 (1.50)	35 (1.38)	31 (1.22)	27 (1.06)	23 (0.91)	19 (0.75)
	10° (50°)								50 (1.97)	46 (1.81)	43 (1.69)	39 (1.54)	36 (1.42)	32 (1.26)	29 (1.14)	25 (0.98)	21 (0.83)	18 (0.71)
	5° (41°)						50 (1.97)	47 (1.85)	43 (1.69)	40 (1.57)	37 (1.46)	33 (1.30)	30 (1.18)	27 (1.06)	23 (0.91)	20 (0.79)	17 (0.67)	
	0° (32°)					50 (1.97)	47 (1.85)	44 (1.73)	41 (1.61)	38 (1.50)	34 (1.34)	31 (1.22)	28 (1.10)	25 (0.98)	22 (0.87)	19 (0.75)	16 (0.63)	
	-5° (23°)			50 (1.97)	47 (1.85)	44 (1.73)	41 (1.61)	38 (1.50)	35 (1.38)	32 (1.26)	29 (1.14)	26 (1.02)	24 (0.94)	21 (0.83)	18 (0.71)	15 (0.59)		
	-10° (14°)		50 (1.97)	47 (1.85)	44 (1.73)	42 (1.65)	39 (1.54)	36 (1.42)	33 (1.30)	31 (1.22)	28 (1.10)	25 (0.98)	22 (0.87)	19 (0.75)	17 (0.67)	14 (0.55)		
	-15° (5°)		50 (1.97)	47 (1.85)	45 (1.77)	42 (1.65)	39 (1.54)	37 (1.46)	34 (1.34)	32 (1.26)	29 (1.14)	26 (1.02)	24 (0.94)	21 (0.83)	18 (0.71)	16 (0.63)	13 (0.51)	
	-20° (-4°)		50 (1.97)	48 (1.89)	45 (1.77)	43 (1.69)	40 (1.57)	38 (1.50)	35 (1.38)	33 (1.30)	30 (1.18)	28 (1.10)	25 (0.98)	23 (0.91)	20 (0.79)	18 (0.71)	15 (0.59)	13 (0.51)
	-25° (-13°)	50 (1.97)	48 (1.89)	45 (1.77)	43 (1.69)	40 (1.57)	38 (1.50)	36 (1.42)	33 (1.30)	31 (1.22)	29 (1.14)	26 (1.02)	24 (0.94)	21 (0.83)	19 (0.75)	17 (0.67)	14 (0.55)	12 (0.47)

TOTAL GAP SETTING: mm (in)

## 16.0 Assembly of End Power feed (60 Amp & 100 Amp Conductor Bar Only)

P/N 310911

### Tools Required:

10mm A/F wrench Suitable sharp knife Cable Stripper Cable Crimping tool Suitable cable terminal (see list on page 16, for recommended suppliers and references).

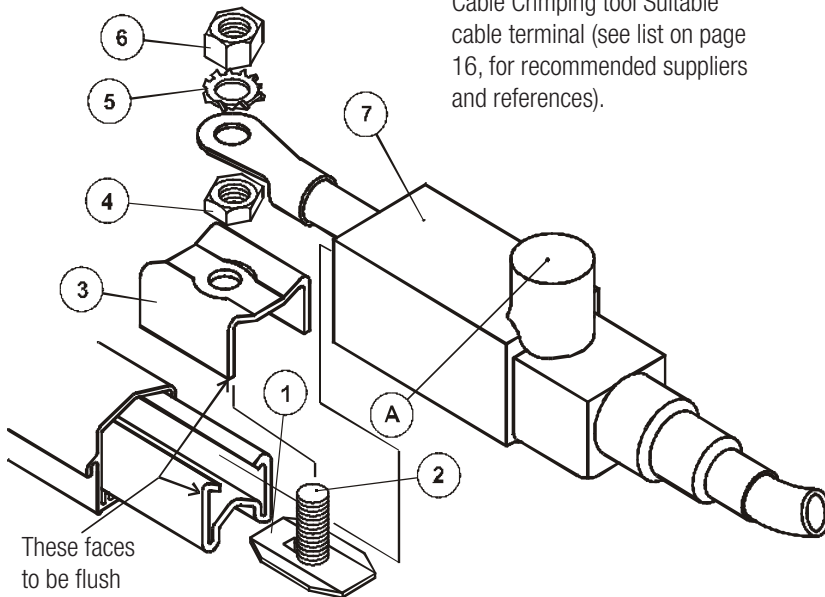

1. Cut item 7 to suit cable diameter.
2. Pass cable through item 7.
3. Crimp terminal to cable.
4. Fit item 2 into item 1. Note: tab to face downward
5. Fit assembly into conductor bar.
6. Fit item 3 over items 1 & 2. Secure with HALF NUT item 4. Tighten item 4 to Conductix recommended torque value of 10Nm (7-8 ft-lbs).
7. Fit terminal and secure items 5 & 6.
8. Tighten item 6 to Conductix recommended torque of 8 Nm (5-6 ft-lbs).
9. Push item 7 over assembly. (Ensure item 2 is located in point "A" on item 7).

### Max cable size:

25 sq. mm pvc 600/100V stranded copper conductor (#4 AWG Extra Flexible).

## 17.0 Assembly of Low Amp Joint Power feed (Up to 100 Amp)

P/N 310034

Max cable size 10sq. mm pvc 600/1000V stranded copper conductor (#8 AWG Extra Flexible).

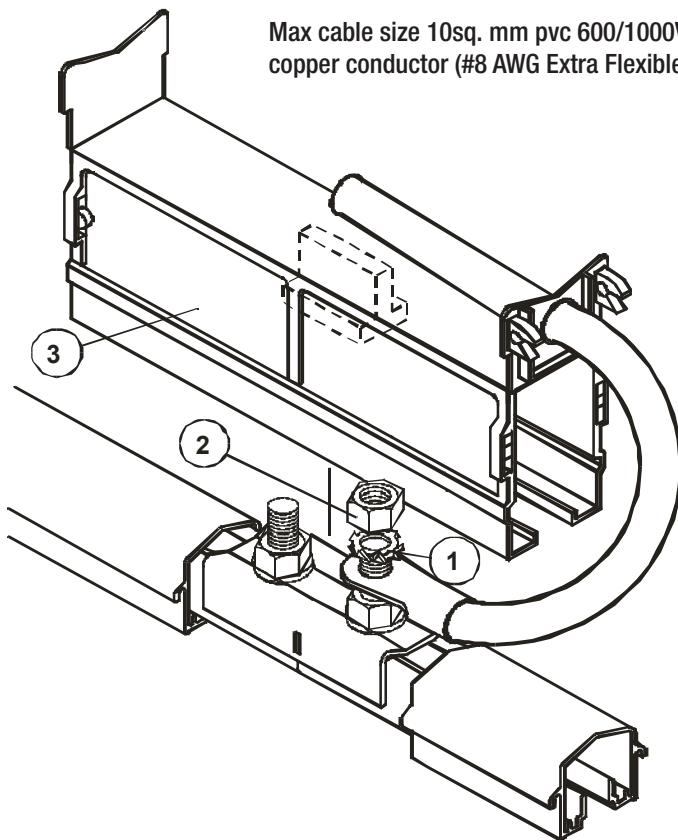

### Tools Required:

10mm A/F wrench Suitable sharp knife Cable Stripper Cable Crimping tool Suitable cable terminal (see list on page 16, for recommended suppliers and references).

1. Remove black plug on item 4.
2. Assemble joint to conductor bar as described previously in the book.
3. Pass supply cable through grommet.
4. Crimp terminal to supply cable.
5. Secure terminal to joint using 1 & 2 and tighten item 2 to a Conductix recommended torque of 8 Nm (5-6 ft-lbs).
6. Fit item 3 over assembly. Ensure the cable is threaded carefully through grommet.
7. Once in position close flaps and ensure flaps click home.
8. **Note:** Joint must not support the cable.

## 18.0 Assembly of Low Amp Joint Power feed

P/N 310910 and 310912

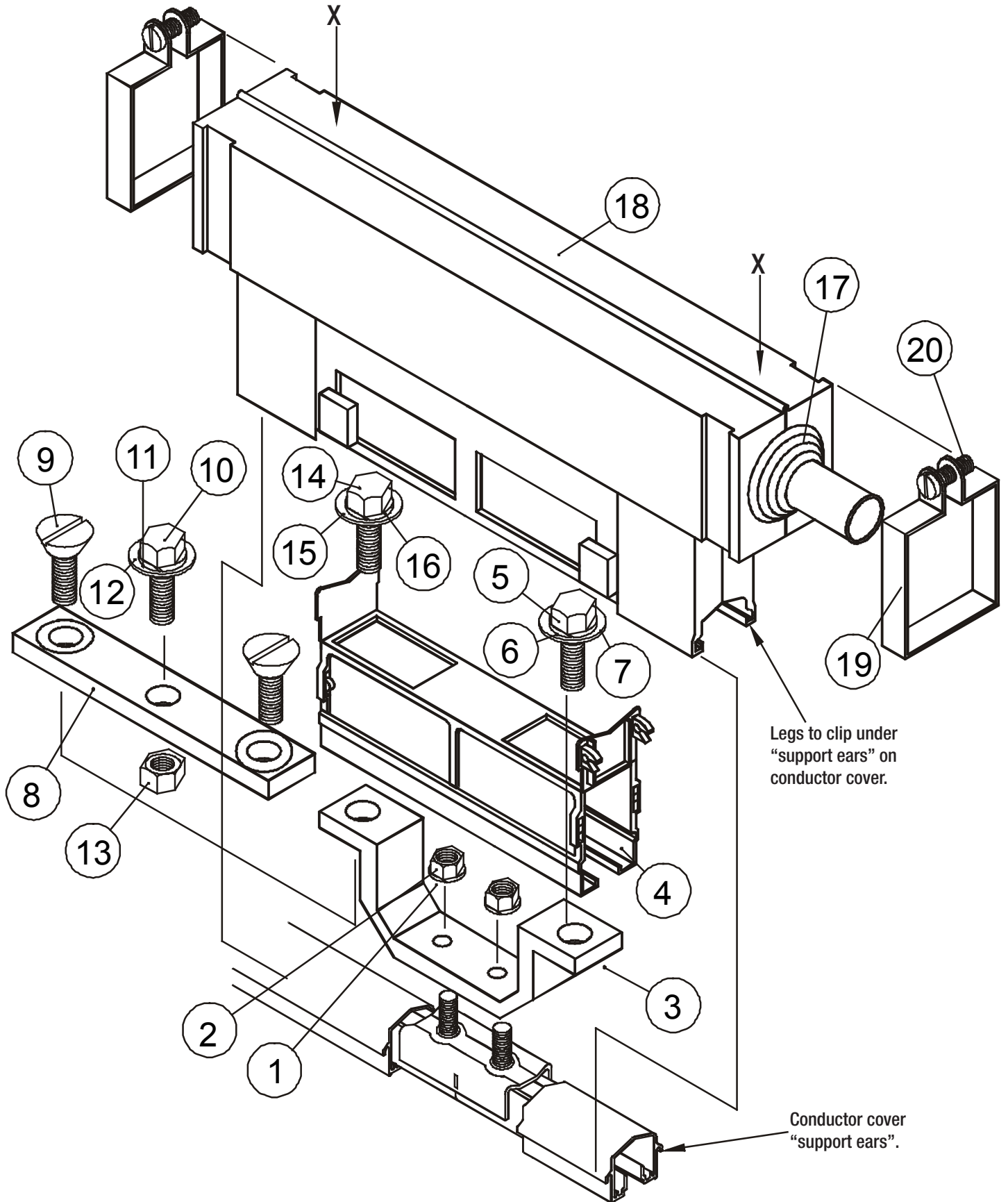



## 19.0 Assembly of Power feed and Cover

### Up to and including 250 Amps P/N 310910

1. Assemble joint to conductor bar as described previously in the book (Do not fit items 1 & 2).
2. Fit aluminum to hat section item 3 to joint assembly. (On copper and aluminum conductors apply Electrical Join Compound (EJC) between mating surfaces).
3. Discard spring washers originally fitted to the joint assembly and fit external tooth lock washers item 1 (supplied in the kit) along with nuts item 2 and tighten to a Conductix recommended torque of 8 Nm (5-6 ft-lbs).
4. Fit joint power feed cover item 4 as shown previously in the book.
5. Cut out grommet item 17 using suitable knife and fit over cable.
6. Crimp terminal to supply cable. (See list on page 16 for recommended terminals).
7. Ensure the terminal is properly crimped as failure to do so will result in over-heating on the power feed assembly.
8. Fit terminal to item 3 and secure using items 5, 6 & 7. Torque item 5 to 8 Nm (5-6 ft-lbs).
9. Items 14, 15 & 16 are for use with two cable feeds and should be left tight on item 3 if only one feed is used.
10. Fit Power feed cover item 18 to assembly.
11. Ensure both grommets are fitted into item 18 before closing halves together.
12. Make sure the legs of the cover fit under the conductor cover support ears. (A little pressure at points "x-x" will ensure this).
13. Fit items 19 to item 18 and secure with items 20.

### Over 250 up to 400 Amps P/N 310912

1. Assemble joint to conductor bar as described previously in the book (Do not fit items 1 & 2).
2. Fit aluminum to hat section item 3 to joint assembly. (On copper and aluminum conductors apply Electrical Join Compound (EJC) between mating surfaces).
3. Discard spring washers originally fitted to the joint assembly and fit external tooth lock washers item 1 (supplied in the kit) along with nuts item 2 and tighten to a Conductix recommended torque of 8 Nm (5-6 ft-lbs).
4. Fit joint power feed cover item 4 as shown previously in the book.
5. Apply EJC between mating surfaces on items 3 & 8
6. Place item 8 over item 3 and secure with items 9. Torque item 9 to 8 Nm (5-6 ft-lbs).
7. Cut out grommet item 17 using suitable knife and fit over cable.
8. Crimp terminal to supply cable. (See list on page 16 for recommended terminals).
9. Ensure the terminal is properly crimped as failure to do so will result in over-heating on the power feed assembly.
10. Apply EJC to the center are of item 8.
11. Fit lug to the center of item 8 and secure using items 10, 11, 12 & 13 in the order shown. Torque item 10 to 8 Nm (5-6 ft-lbs).
12. Fit power feed cover item 18 to assembly.
13. Ensure both grommets are fitted to item 18 before closing halves together.
14. Make sure the legs of the cover fit under the conductor cover support ears. (A little pressure at points "x-x" will ensure this).
15. Fit items 19 to item 18 and secure with items 20.

## 20.0 Terminal Chart for Guidelines Only

T&B terminal part numbers are for reference only. Dimensions shown are the maximum allowable sizes. All power feeds must have expansion loops incorporated in their installation. Conductix DOES NOT recommend the termination of solid conductors into their power feed assemblies. (Flexible Cables are Recommended.)

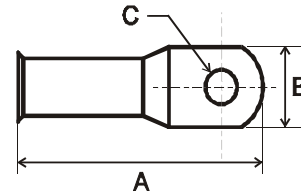

Power feed	T&B P/N	Dim "A"	Dim "B"	Dim "C"	Cable Size	
P/N 310910	310001	D72	1.32	.59	5/16	8 AWG
	310101	E72	1.32	.60	5/16	6 AWG
	310201	F72	1.35	.60	5/16	4 AWG
	310301	G972	1.59	.69	5/16	1-2 AWG
	310601	J972	1.94	.84	5/16	#1/0AN-#2/0
	310401	L973	2.25	1.04	3/8	#3/0AN-#4/0
P/N 310912	310701	M972	2.28	1.12	5/16	#4/0AN-250kcmil
	310501	54178	2.33	1.25	5/16	300 kcmil
End Power feed P/N 310911	310001	D71	1.13	.48	1/4	8 AWG
	310101	E71	1.13	.48	1/4	6 AWG
Low Amp Joint Power feed P/N 310034	310001	D71	1.13	.48	1/4	8 AWG

## 21.0 Mounting Details for DI Collector

P/N 310990 Red  
P/N 399355 Green

This collector is rated at 50 Amps continuously in a stationary position on copper & galvanized steel. It is rated for 25 amps on Aluminum / Stainless for the same condition.

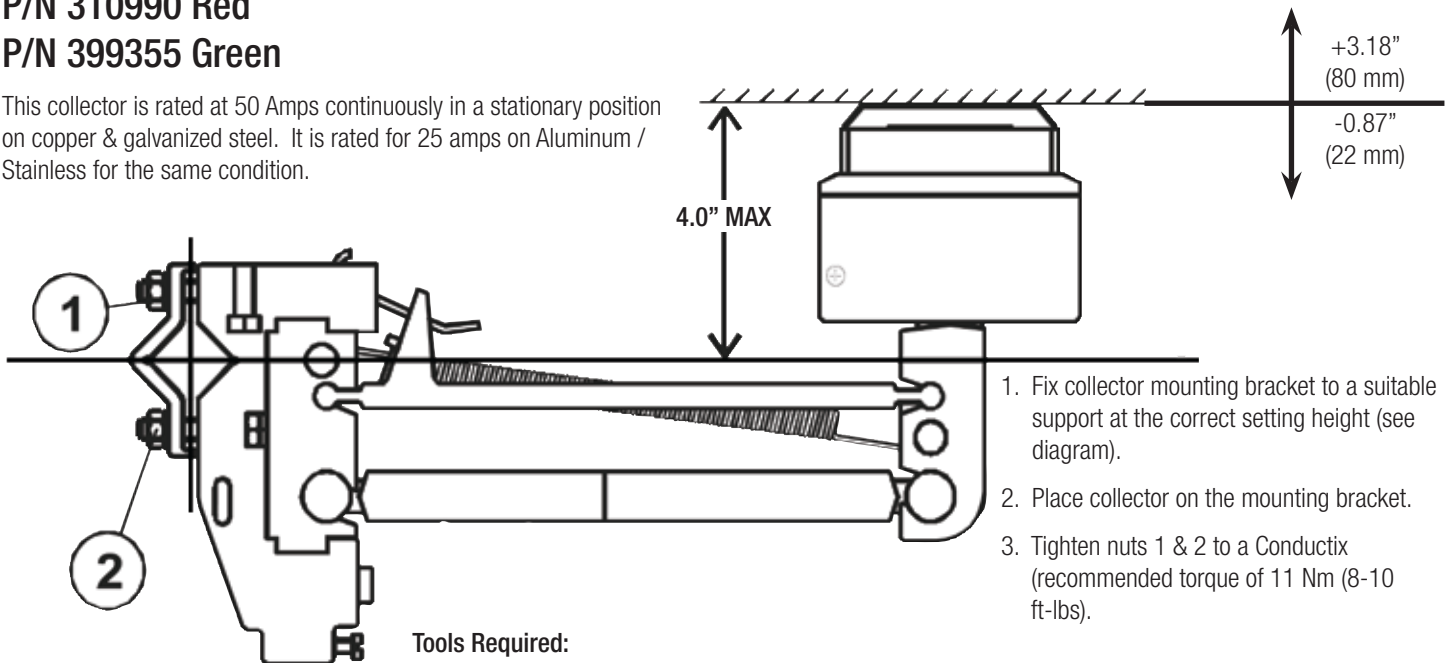

1. Fix collector mounting bracket to a suitable support at the correct setting height (see diagram).
2. Place collector on the mounting bracket.
3. Tighten nuts 1 & 2 to a Conductix (recommended torque of 11 Nm (8-10 ft-lbs)).

**Tools Required:**  
13mm A/F wrench  
Steel rule or suitable tape measure  
Flat bladed screwdriver  
Cable Stripper



## 22.0 Mounting Details for SI Collector

P/N 310990 Red  
P/N 399355 Green

This collector is rated for 25 Amps continuous in a stationary position on copper galvanized steel. It is rated for 12 Amps on Aluminum / Stainless for the same condition.

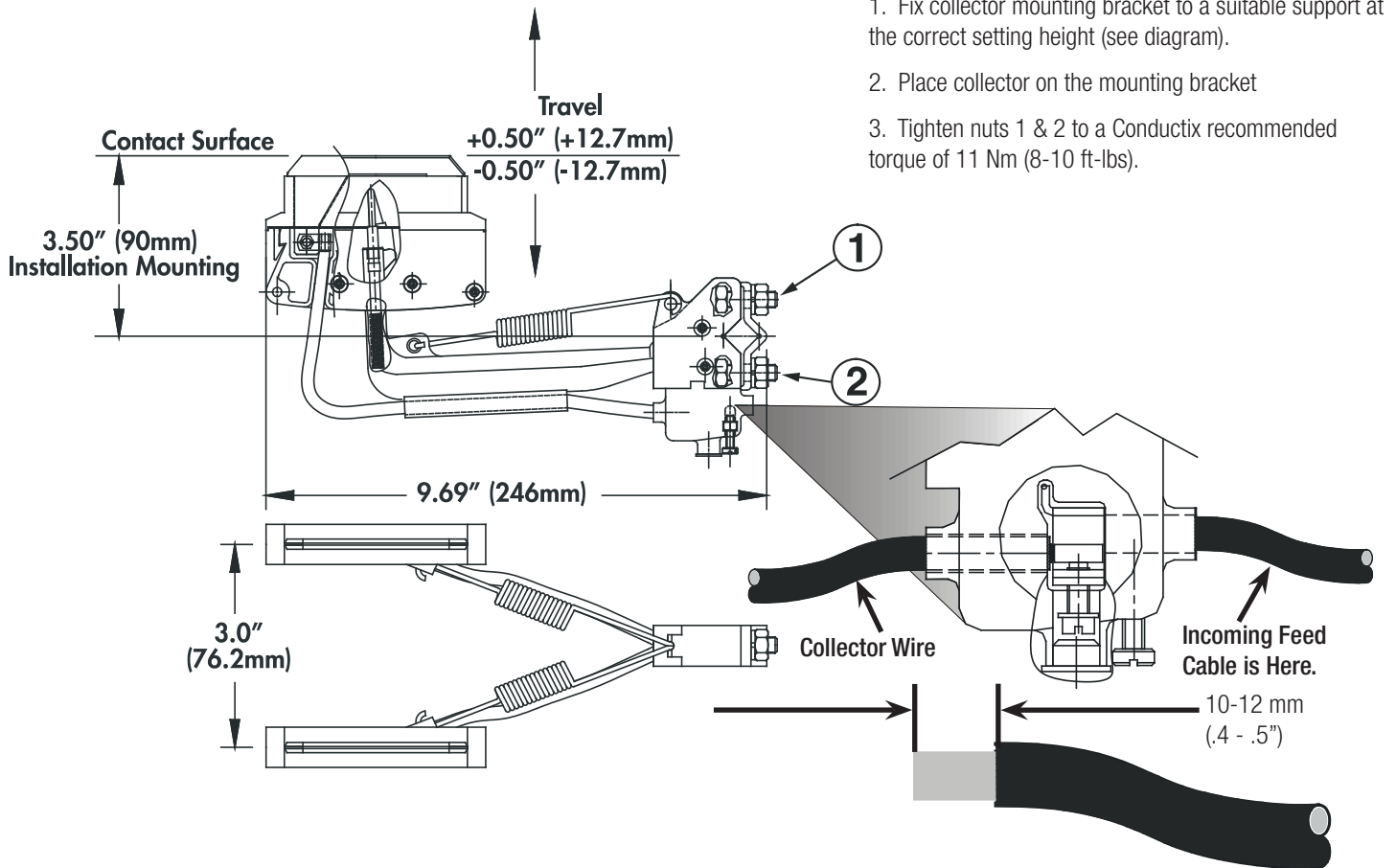

## 23.0 Customer Supplied Cable Installation

1. Strip customer supplied cable back 13 - 15 mm (0.5-0.6"), using a suitable cable stripping tool.
2. Remove protection plug from the hole.
3. Loosen screw number 1.
4. Loosen screw number 2 until clear from entry hole.
5. Push customer supply cable into entry hole.
6. Tighten screw number 1 fully and ensure that the cable is clamped firmly into position.
7. Tighten cable clamp screw number 2.
8. Replace protection plug.

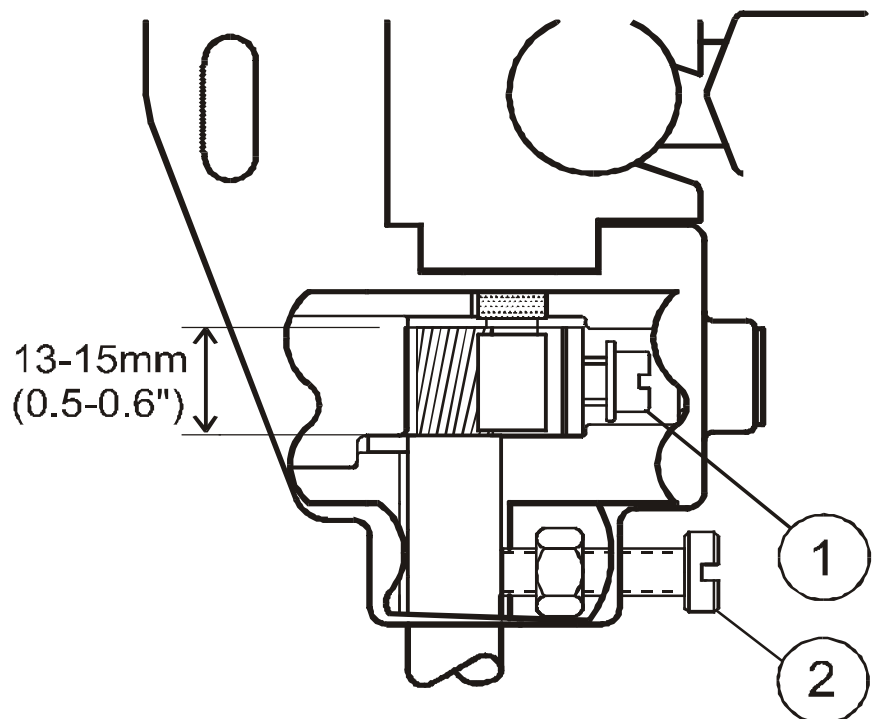

## 24.0 Amp Collector

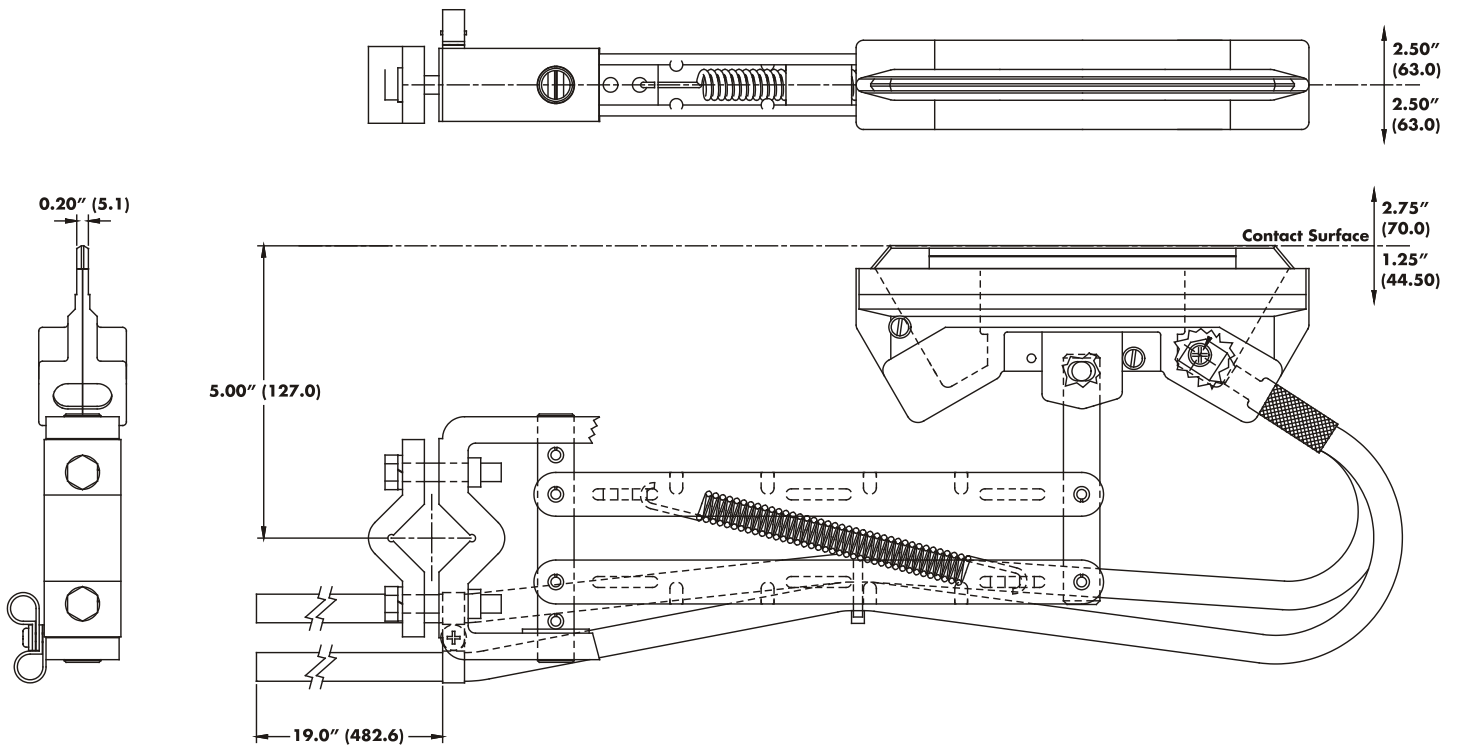

Torque mounting hardware to 15 Nm. (10 - 12 ft-lbs)

**Note:** This collector is UL rated at 100 Amps continuous duty in a stationary position on copper and galvanized steel. It is rated at 50 Amps on Aluminum Stainless for the same condition.

## 25.0 Assembly of Transfer Cap

### P/N 310951

1. Mark conductor cover 22mm (0.87") in from end of cover
2. Gently tap transfer cap item 1 onto bar and cover assembly using a soft mallet
3. Line up back edge of transfer cap with mark on the cover
4. Install transfer cap into support bracket (not shown) at 43mm (1.7") centers
5. Fit items 2, 3, & 4 in the order shown
6. Tighten item 4 to a Conductix recommended torque of 28.4 Nm (20 - 21 ft-lbs).

#### Tools Required

13mm A/F wrench  
Soft mallet

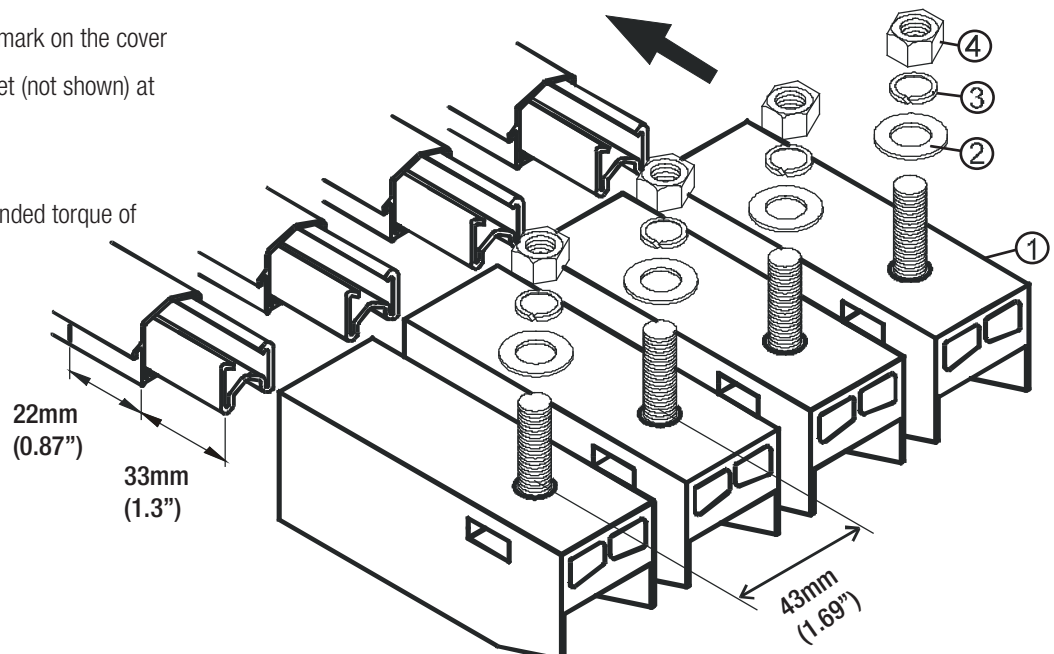

## 26.0 Transfer Cap Mounting Details

Side view of transfer caps showing maximum alignment tolerance.

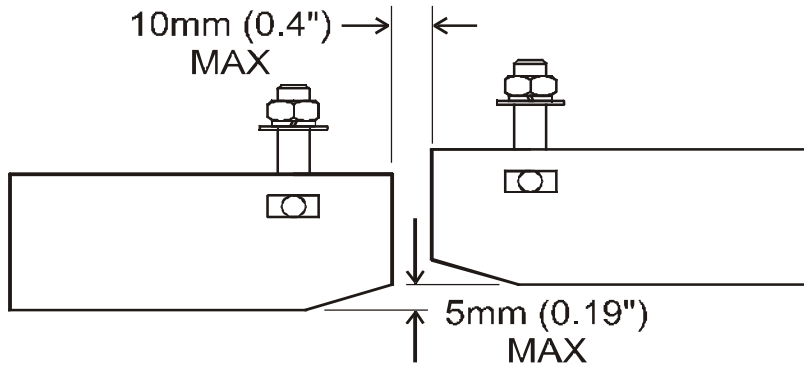

Plan view of transfer caps showing maximum alignment tolerance.

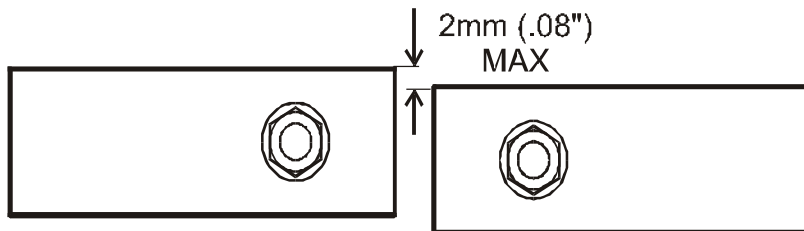

Please note: Where transfer caps are used in a system, tandem collectors must be used.

## 27.0 Assembly of Isolation Splice Assemblies

P/N 310972 & 310973 (310973 Not Shown)

### Tools Required:

10mm A/F open ended wrench

1. Fit item 4 into item 5. (Ensure tab captivates the head on the setscrew).
2. Slide item 4 and item 5 into item 6 and item 7 respectively.
3. Place item 3 over item 4.
4. Fit items 2 and 1 in the order shown.
5. Tighten items 1 to a Conductix recommended value of 8 Nm (5-6 ft-lbs).

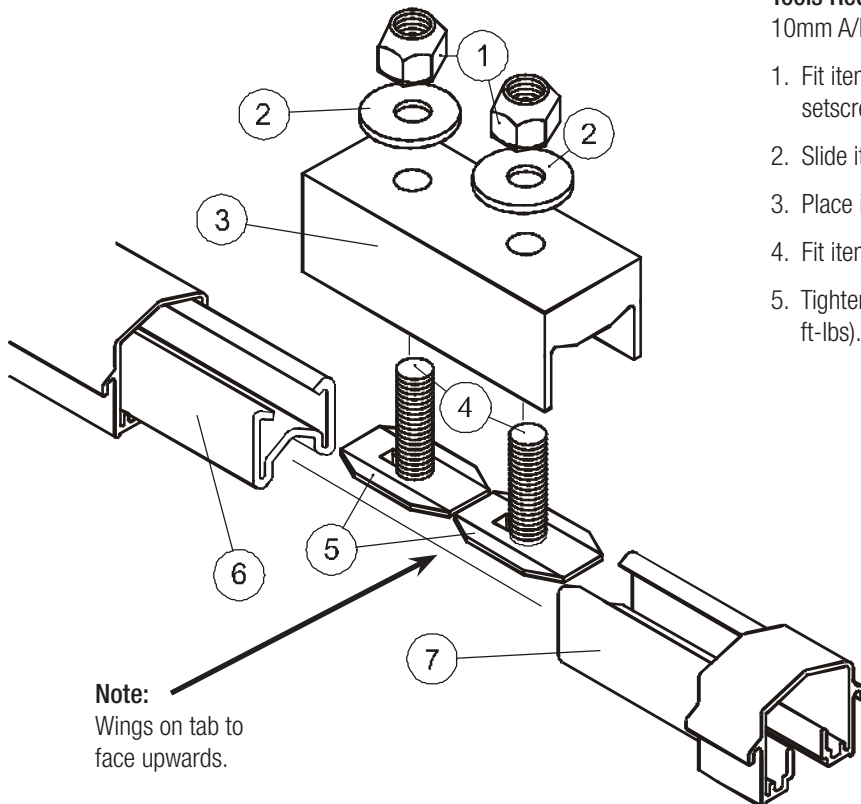

**Note:**  
Wings on tab to  
face upwards.

## 28.0 System Maintenance and Installation Notes

### Installation Notes:

1. Ensure all power is disconnected before attempting to install or maintain the system.
2. Ensure all electrical joints are free from any contamination.
3. Ensure correct alignment and location of support brackets.
4. Ensure conductor joints are not against hanger clamps. Adequate clearance must be allowed for expansion and contraction.
5. Ensure correct alignment of collector with conductor bar. Collector arms should be parallel with contact surface.
6. Ensure all power cables are flexible to allow expansion and contraction of the conductor bar system.
7. Ensure all armored cables are terminated into a suitable junction box and only flexible cables are installed into the power feed assemblies.
8. Ensure conductor bars DO NOT support the weight of the feed cables.
9. Conductix recommends that the first accessible conductor bar should be the ground bar.

### Maintenance Notes:

1. Contact shoes should be checked for wear on a monthly basis until a wear pattern can be established.
2. Check alignment of collector and conductor bars. Base of collector should be directly in-line with associated conductor.
3. Check conductor system to ensure no damage to insulation cover.
4. In environments that are subject to considerable build up of dust, especially conductive dust, remove this dust at regular intervals by brushing.
5. Check collector pivot points and free from any contamination.
6. Uneven shoe wear indicates less than optimal collector alignment.

## 29.0 Replacement of Di & SI Collector Contact Shoe and Shoe Holder

**Note:** Collector contact shoe and shoe holder are supplied as replacement Part No. 310993 Ground Conductor - Part No. 399357 (For Ground Shoes with deflector consult factory)

### Tools Required:

Flat blade screwdriver

7mm A/F wrench

1. Lever lugs in direction shown
2. Lift shoe and holder
3. Disconnect Cable
4. Reverse procedure to install new shoe

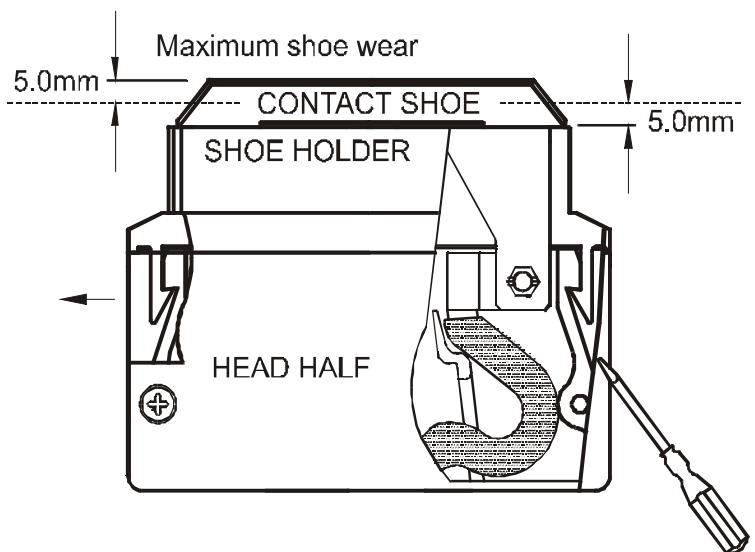

## 30.0 Replacement of 250 Amp Collector Contact Shoe

Replace shoe (34958) after worn to wear line.

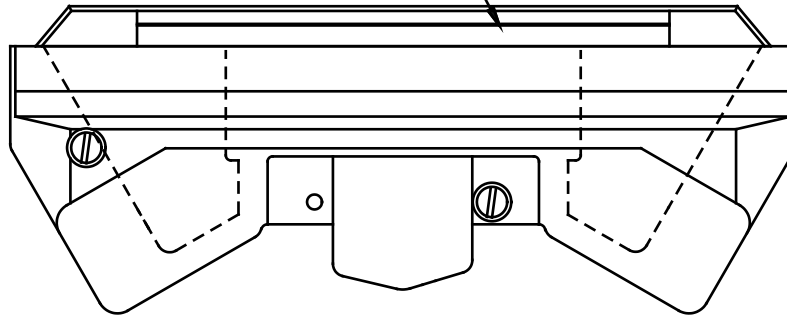

## 31.0 Assembly Instructions for Single, Two, Three, and Four-way Pickup Guide

1. Remove items 2, 3 & 4
2. Remove transfer caps from pickup guide. * Note: Bracket width must not exceed 40.0mm (1.55")
3. Fit transfer caps on to the ends of the conductor bars. (See instructions 1 to 3 on page 25).
4. Ensure any hanger clamps are at least one meter back from the transfer caps.
5. Squeeze transfer caps together and fit pickup guide over item 1.
6. Fit transfer cap support bracket over item 1.
7. Fit items 2, 3 & 4 in order shown.
8. Tighten item 2 to a Conductix recommended torque of 28.4 Nm. (20-21 ft-lbs).
9. Remove items 6, 7 & 8.
10. Fit bracket over item 5.
11. Fit items 6, 7 & 8.
12. Tighten item 6 to a Conductix recommended torque of 28.4 Nm (20-21 ft-lbs).

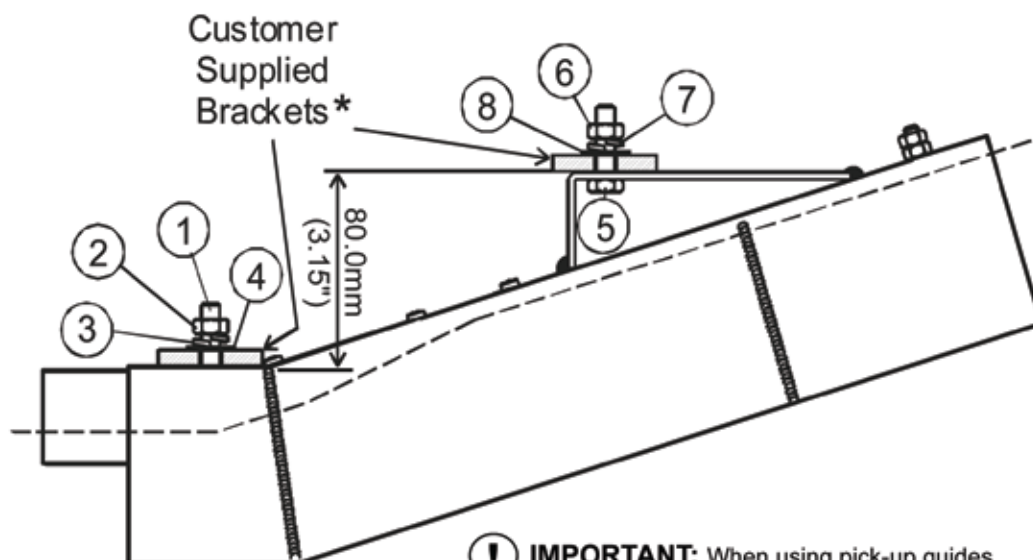

**!** **IMPORTANT:** When using pick-up guides, you must use collector part numbers: 310988 & 399358. Please consult factory when ordering

\* - Bracket width must not exceed 40.0mm (1.55")

## 32.0 Diagram Showing Hanger Centers

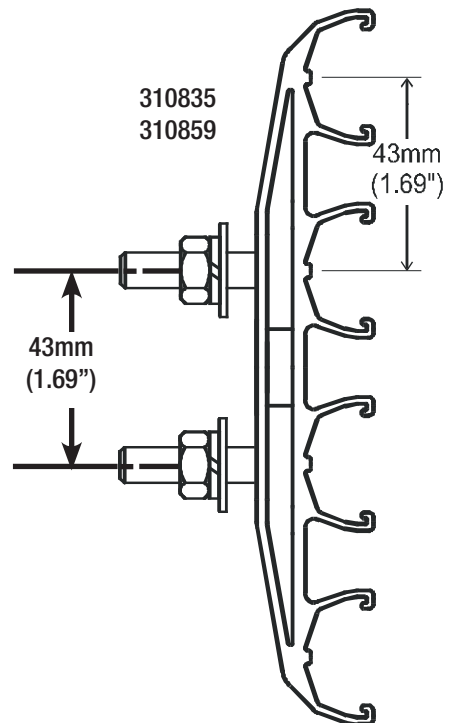
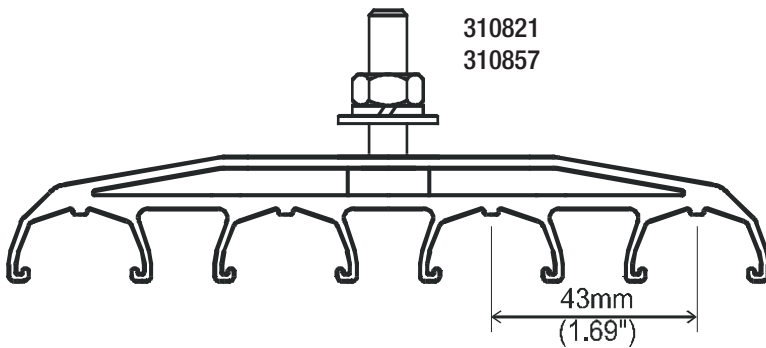
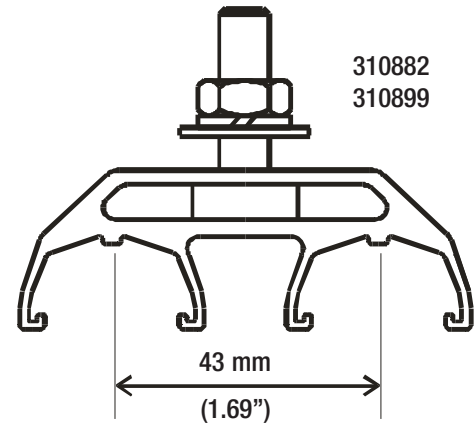
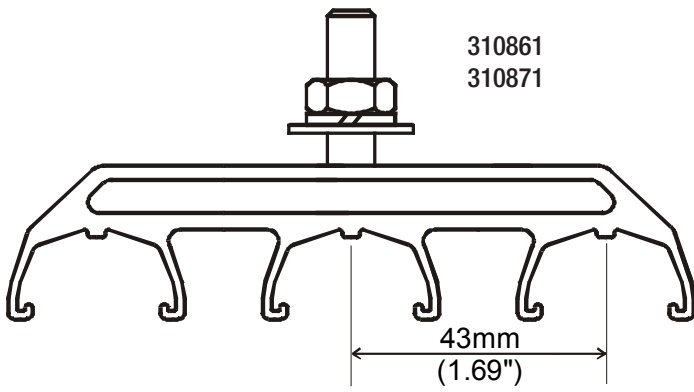
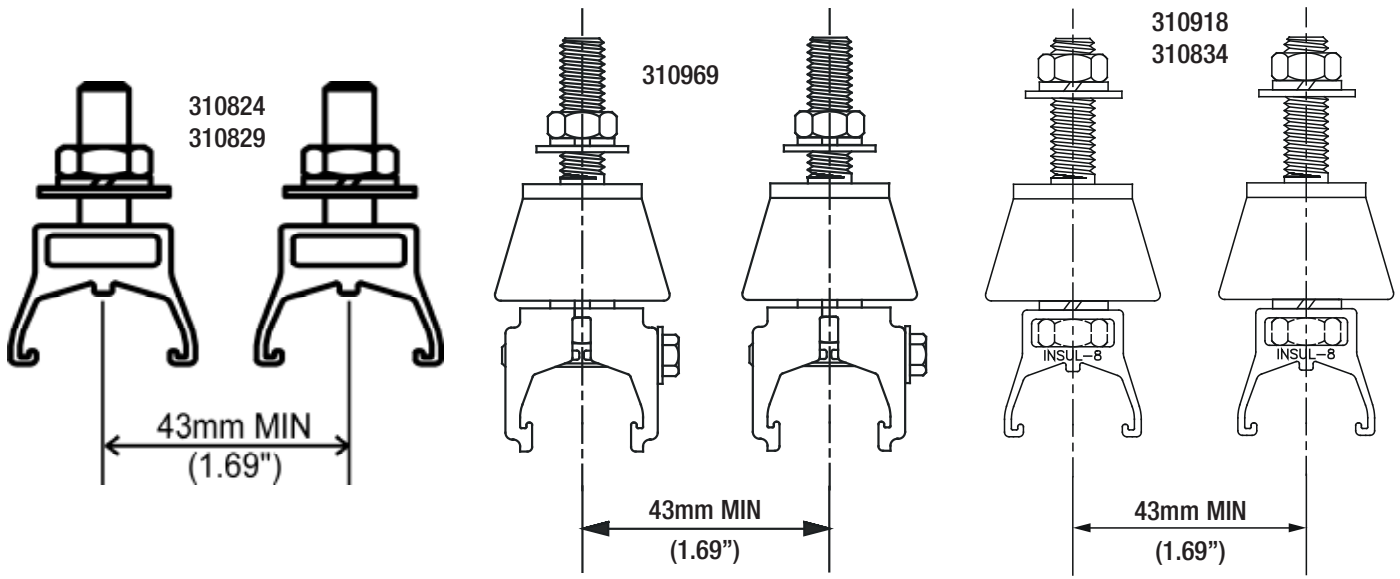

# 33.0 Conductor Bar De-Rating Chart

## Conductor De-rating

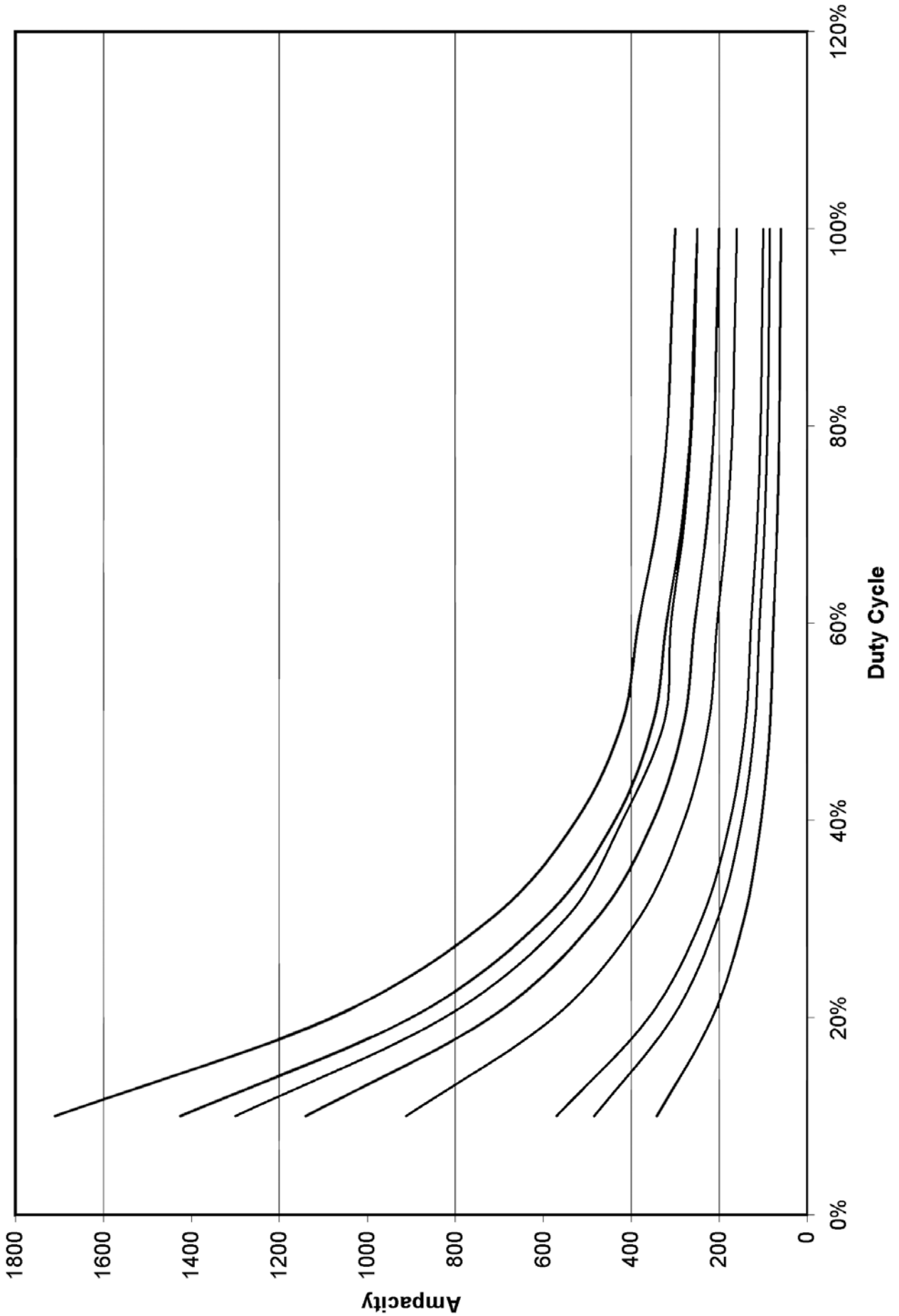

[www.conductix.com](http://www.conductix.com)

**Conductix-Wampfler**

10102 F Street  
Omaha, NE 68127  
USA

Customer Support  
Phone: 800 521 4888  
Fax: 800 780 8329

Phone: 402 339 9300  
Fax: 402 339 9627

[info.us@conductix.com](mailto:info.us@conductix.com)  
[www.conductix.com](http://www.conductix.com)

