

Operating, Maintenance & Parts Manual

Series 635

Motor Driven Trolley



Capacities

1/8 - 2 and 3-Tons

Follow all instructions and warnings for inspecting, maintaining and operating this trolley.

The use of any hoist and trolley presents some risk of personal injury or property damage. That risk is greatly increased if proper instructions and warnings are not followed. Before using this trolley, each operator should become thoroughly familiar with all warnings, instructions, and recommendations in this manual.

Retain this manual for future reference and use. Forward this manual to the hoist operator. Failure to operate the equipment as directed in the manual may cause injury.

Before using the hoist, fill in the information below. Refer to the hoist identification plate.

Model Number _____

Serial Number _____

Purchase Date _____

Voltage _____

CM[®]
COLUMBUS MCKINNON CORPORATION
INDUSTRIAL PRODUCTS DIVISION
140 JOHN JAMES AUDUBON PARKWAY
AMHERST, NEW YORK 14228-1197

CM HOIST PARTS AND SERVICES ARE AVAILABLE IN THE UNITED STATES AND IN CANADA

As a CM Hoist user, you are assured of reliable repair and parts services through a network of Master Parts Depots and Service Centers that are strategically located in the United States and Canada. These facilities have been selected on the basis of their demonstrated ability to handle all parts and repair requirements promptly and efficiently.

Below is a list of the Master Parts Depots in the United States and Canada. To quickly obtain the name of the U.S. Service Center located nearest you, call (800) 888-0985. Fax: (716) 689-5644. In the following list, the Canadian Service Centers are indicated.

UNITED STATES MASTER PARTS DEPOT

CALIFORNIA

OTTO SYSTEMS, INC.
12010 Bloomfield Ave.
Sante Fe Springs, CA 90670
562/462-1612 or 800/596-7392
Fax 562/462-1617

or
7656 Las Positas Road
Livemore, CA 94551
925/245-8800
Fax 925/245-8804

GEORGIA

ACE INDUSTRIES, INC.
6295 McDonough Drive
Norcross, GA 30093
770/441-0898 or 800/733-2231
Fax 800/628-3648

INDIANA

HORNER ELECTRIC COMPANY, INC.
1521 East Washington Street
Indianapolis, IN 46201
317/639-4261
Fax 317/639-4342

IOWA

VMI HOIST & CRANE SERVICES
901 17th Street NE
Cedar Rapids, IA 52406
319/365-4662
Fax 319/365-8075

KANSAS

INDEPENDENT ELECTRIC MACHINERY
4425 Oliver Street
Kansas City, KS 66106
913/362-1155
Fax 913/904-3330

LOUISIANA

BEERMAN PRECISION, INC.
4206 Howard Ave.
New Orleans, LA 70125
504/486-9391
Fax 504/486-7482

MASSACHUSETTS

ABEL DISTRIBUTORS, INC.
50 Parker Street, Unit 2
Newburyport, MA 01950
978/463-0700
Fax 978/463-5200

NEW JERSEY

SHUPPER-BRICKLE EQUIPMENT CO.
2394 Route 130, Suite C
Dayton, NJ 08810
732/438-3888
Fax 732/438-3889

NEW YORK

VOLLAND ELECTRIC EQUIPMENT CO.
75 Innsbruck Drive
Buffalo, NY 14227
716/656-9900
Fax 716/656-8898/8899

NORTH CAROLINA

TEAM SESCO
2225 Freedom Drive
Charlotte, NC 28208
704/372-4832 or 800/487-3726
Fax 704/358-1098

OHIO

MAZZELLA LIFTING TECHNOLOGIES
21000 Aerospace Parkway
Cleveland, OH 44142
440/239-5700 or 800/362-4601
Fax 440/239-5707

PENNSYLVANIA

AMICK ASSOCIATES, INC.
11 Sycamore Street
Carnegie, PA 15106-0529
412/429-1212 or 800/445-9456
Fax 412/429-0191

RAM MOTORS & CONTROLS, INC.

5460-B Pottsville Pike
Leesport, PA 19533
610/916-8000 or 877/916-8018
Fax 610/916-7957

TEXAS

ABEL EQUIPMENT CO., INC.
3710 Cavalier Drive
Garland, TX 75042
972/272-7706
Fax 972/272-6955

HYDRAULIC EQUIPMENT SERVICES, INC.

1021 North San Jacinto Street
Houston, TX 77002
713/228-9601
Fax 713/228-0931

WISCONSIN

TRESTER HOIST & EQUIPMENT, INC.
W136 N4863 Campbell Drive
Menomonee Falls, WI 53051
262/790-0700 or 800/234-6098
Fax 262/790-1009

CANADIAN SERVICE CENTERS

ALBERTA

BENNETT & EMMOTT, LTD.
18131 118th Avenue
Edmonton, Alberta T5S 1M8
403/454-9000
Fax 403/454-8990

**COLUMBUS McKINNON, LTD.

10311-174th Street
Edmonton, Alberta T5S 1H1
800/263-1997
Fax 403/486-6160

BRITISH COLUMBIA

FLECK BROTHERS, LTD.
4084 McConnel Court
Burnaby, British Columbia V5A 3N7

MANITOBA

KING'S ELECTRIC MOTORS, INC.
633 Tyne Avenue
Winnipeg, Manitoba R2L 1J5
204/663-5332
Fax 204/663-4059

NOVA SCOTIA

*W & A MOIR
95 Ilsley Ave.
Burnside Park, Nova Scotia B3B 1L5
902/468-7720
Fax 902/468-3777

ONTARIO

*R & W HOIST REPAIR, LTD.
790 Redwood Square
Units 5, 6, & 7
Oakville, Ontario L6L 6N3
905/825-5500
Fax 905/825-5315

*TORONTO ELECTRIC HOIST

SALES & SERVICE
9 CoDeco Court
North York, Ontario M3A 1A1
416/386-0820
Fax 416/386-0821

*MASLACK SUPPLY, LTD.

488 Falconbridge Road
Sudbury, Ontario P3A 4S4
705/566-1270
Fax 705/566-4208

*COLUMBUS McKINNON, LTD.

P.O. Box 1106
10 Brook Road, North
Cobourg, Ontario K9A 4W5
905/372-0153
Fax 905/372-3078

QUEBEC

*HERCULES SLING & CABLE
3800 TransCanada Highway
Pointe-Claire, Quebec H9R 1B1
514/428-5511
Fax 514/428-5555

*LEGER PALANS ET OUTILLAGES, INC.

7995-17th Ave.
Montreal, Quebec H1Z 3R2
514/376-3050
Fax 514/376-0657

*ARE ALSO MASTER PARTS DEPOTS

**MASTER PARTS DEPOT ONLY

SAFETY PRECAUTIONS

Each Series 635 Motor Driven Trolley is built in accordance with the specifications contained herein and at the time of manufacture complied with our interpretation of applicable sections of the *American Society of Mechanical Engineers Code B30.11 "Monorail Systems and Underhung Cranes," the National Electrical Code (ANSI/NFPA 70) and the Occupational Safety and Health Act. Since OSHA states the National Electrical Code applies to all electrical installations and utilization equipment, installers are required to provide current overload protection and grounding in keeping with the code. Check each installation for compliance with the application, operation and maintenance sections of these articles.

After you have completely familiarized yourself with the contents of this manual, we recommend that you carefully file it for future reference.

*Copies of this standard can be obtained from ASME Order Department, 22 Law Drive, Box 2300, Fairfield, NJ 07007-2300, U.S.A.



THIS SYMBOL POINTS OUT IMPORTANT SAFETY INSTRUCTIONS WHICH IF NOT FOLLOWED COULD ENDANGER THE PERSONAL SAFETY AND/OR PROPERTY OF YOURSELF AND OTHERS. READ AND FOLLOW ALL INSTRUCTIONS IN THIS MANUAL AND ANY PROVIDED WITH THE EQUIPMENT BEFORE ATTEMPTING TO OPERATE YOUR SERIES 635 MOTOR DRIVEN TROLLEY.



WARNING

Improper operation of a trolley can create a potentially hazardous situation which, if not avoided, could result in death or serious injury. To avoid such a potentially hazardous situation, the operator shall follow these operating and safety procedures.

OPERATING AND SAFETY PROCEDURES

The following are operating and safety procedures for safe operation of the Series 635 Motor Driven Trolley. Taking precedence over any specific rules listed here, however, is the most important rule of all, USE COMMON SENSE. A few minutes spent reading these rules can make an operator aware of dangerous practices to avoid and precautions to take for his own safety and the safety of others. Frequent examinations and periodic inspections of the equipment as well as a conscientious observance of safety rules may save lives as well as time and money.

1. Immediately after installation, operate trolley (according to the Operating and Safety Procedures as follows) with a capacity load over the entire length of runway or monorail system to be sure that all adjustments and operations are satisfactory.
2. Rail stops must be installed for all trolleys operating on open end beams. These stops must be positioned such that impact forces are absorbed by the trolley side frames only.
3. When preparing to lift a load, be sure that the attachments to the hook are firmly seated in hook saddle. Avoid off-center loading of any kind, especially loading on the point of hook.
4. When lifting, raise the load only enough to clear the floor or support and check to be sure that the attachments to hook and load are firmly seated. Continue lift only after you are assured the load is free of all obstructions.
5. When applying a load, it should be directly under the trolley. Avoid off-center loading of any kind.
6. Take up a slack load chain carefully and start lifting load slowly to avoid shock and jerking of hoist load chain. If there is any evidence of overloading, immediately lower the load and remove the excess load.
7. **DO NOT** allow the load to swing or twist while hoisting.
8. Anticipate the stopping point and allow trolley to coast to a smooth stop. Reversing or "plugging" to stop trolley causes overheating of motor and swaying of load.
9. **DO NOT** load trolley beyond the rated capacity. Overload can cause immediate failure of load carrying parts or cause damage resulting in future failure at less than rated capacity.
10. **DO NOT** use this or any other overhead materials handling equipment for lifting or transporting people.
11. Stand clear of all loads and avoid moving a load over the heads of other people. Warn people of your intention to move a load in their area.
12. **DO NOT** leave the load suspended in the air unattended.
13. **DO NOT** wrap the load chain around the load and hook onto itself as a choker chain.
Doing this will result in the following:
 - (a) Operation of the upper limit switch is bypassed and the load could hit the hoist.
 - (b) The loss of the swivel effect of the hook which could mean twisted chain and a jammed liftwheel.
 - (c) The chain could be damaged at the hook.
14. Permit only qualified personnel to operate unit.

NOTES

FOREWORD

This manual contains important information to help you properly install, operate and maintain the Series 635 Motor Driven Trolley for maximum performance, economy and safety.

Please study its contents thoroughly before putting your trolley into operation. By practicing correct operating procedures and by carrying out the recommended preventive maintenance suggestions, you will experience long, dependable and safe service.

After you have completely familiarized yourself with the contents of this manual, we recommend that you carefully file it for future reference.

TABLE OF CONTENTS

	PAGE
SAFETY PRECAUTIONS	
Operating and Safety Proceduresii
Foreword	1
GENERAL INFORMATION	
Specifications2
CM Repair/Replacement Policy2
INSTALLATION	
Unpacking Information2
Trolley to Beam2
Hoist to Trolley4
Electrical Installation4
Trolley Motor Cord4
Trolley Power Cord4
Hoist Power Cord5
Control Station5
Hoist Control Cord6
Three-Phase Units6
OPERATING INSTRUCTIONS	
General6
INSPECTION	
Procedures6
MAINTENANCE	
General7
Motor Brake (Optional Equipment)7
Adjustment7
Replacement of Friction Disc7
Replacement of Coils7
Recommended Spare Parts8
TROUBLESHOOTING	
Electrical Data8
Wiring Diagrams9
Cause and Remedy10
REPLACEMENT PARTS	
Ordering Instructions11
Control Stations and Parts List12
Trolley Components and Parts List13
Control Box Components and Parts List14-15
Motor and Gear Reducer	
Components and Parts List17
Motor Brake	
Components and Parts List18

LIST OF TABLES

TABLE	PAGE
1 Series 635 Trolley Specifications2
2 Washer Spacing Charts3
3 Electrical Data for Trolley Components8

LIST OF ILLUSTRATIONS

FIGURE	PAGE
1 Trolley to Beam3
2 Hoist to Trolley (1/8 – 2-Ton) Assembly4
3 Hoist to Trolley (3-Ton) Assembly4
4 Hoist and Trolley – General Arrangement4
5 Hoist Power Cord Connections – Single-Phase5
6 Hoist Power Cord Connections – Three-Phase5
7 Connections for Proper Trolley and Hook Travel6
8 Motor Brake Adjustment7
9 Wiring Diagrams9
10 Trolley Arrangement11
11 Control Stations Exploded Views12
12 Trolley Exploded View13
13 Control Box Exploded View14
14 Motor and Hub City Type Gear Reducer Exploded View16
15 Motor and Peerless-Winsmith Type Gear Reducer Exploded View17
16 Motor Brake Exploded View18

GENERAL INFORMATION

SPECIFICATIONS

The Series 635 Motor Driven Trolleys are designed for use with the Lodestar, and Valustar Electric Chain Hoists. The trolleys are available in two capacities: 1/8 through 2-Tons and 3-Tons. These trolleys are similar except for the sizes of the load carrying members.

The trolleys have rugged steel side plates, hardened steel axles, steel suspension bolts, cast iron load bracket from which the hoist is suspended and hardened cast iron wheels that are suitable for operation on sloped or flat flanged beams. Hardened steel gears are attached to two track-wheels and driven by a right angle worm gear reducer. The worm and gear of the gear reducer operate in an oil bath. A weatherproof motor drives the gear reducer.

The control box contains a reversing contactor, terminal boards and a transformer (as required). A four-button control station is suspended from the control box. An electric brake, which fits between the motor and gear reducer, is available as optional equipment.

Table 1 provides the general specifications for the trolley. It should be noted that the table indicates that the standard travel speed is 75 FPM. However, other travel speeds are available.

CM REPAIR/REPLACEMENT POLICY

All Columbus McKinnon (CM) Series 635 Motor Driven Trolleys are inspected and performance tested prior to shipment. If any properly maintained Series 635 Motor Driven Trolley develops a performance problem, within 1 (one) year of shipment, due to a material or workmanship defect, as verified by CM, repair or replacement of the unit will be made to the original purchaser without charge. This repair/replacement policy applies only to Series 635 Motor Driven Trolleys installed, maintained and operated as outlined in this manual, and specifically excludes parts subject to normal wear, abuse, improper installation, improper or inadequate maintenance, hostile environmental effects and unauthorized repairs/modifications.

We reserve the right to change materials or design if, in our opinion, such changes will improve our product. Abuse, repair by an unauthorized person, or use of non-CM replacement parts voids the guarantee and could lead to dangerous operation. For full Terms of Sale, see Sales Order Acknowledgement. Also, refer to the back cover for Limitations of Warranties, Remedies and Damages, and indemnification and Safe Operation.

INSTALLATION

UNPACKING INFORMATION

After removing the trolley from the shipping carton, carefully inspect the external condition of the cords, control box, gear reducer, motor brake (if equipped with same) and motor for damage that may have occurred during shipment and handling. Check to make sure all parts (trolley side frame assembly with control box, trolley side frame with gear reducer and motor, load bracket, suspension bolts, spacer washer, cotter pins and nuts) are furnished. Also, before attempting to install the trolley, make sure that the power supply indicated on the labels attached to the control box is the same as the power supply on which the unit is to operate.

INSTALLATION

The hoist, trolley and lug suspension for suspending the hoist from the trolley are packed separately. Assemble the lug suspension to the hoist according to the instructions furnished with the suspension and/or the instructions in the manual furnished with the hoist.



WARNING

Operating the trolley on a beam that has no rail stops may allow the trolley to fall off the end of beam.

TO AVOID INJURY:

Install rail stops at each end of the beam on which the trolley is to operate.

The stops must be positioned so as to not exert impact force on the hoist frame or trolley wheels. They must contact the ends of the trolley side frames.

Trolley to Beam

It is recommended that the trolley be mounted on the beam prior to attaching the hoist to the trolley. Before attempting to mount the trolley on the beam, measure the actual width of the beam flange on which the trolley is to operate. Using this measurement, determine the arrangement of the spacer washers using Figure 1 and Table 2. Chart A of Table 2 shows the washer arrangement for the 1/8 – 2-Ton trolley, while Chart B provides data for the 3-Ton trolley. Loosely assemble the side frames, load bracket, spacer washers and nuts on the suspension bolts as shown in Figure 1.

Table 1

Series 635 Motor Driven Trolley Specifications

CODE	DC CODE	CAPACITY (TONS)	FOR USE WITH MODELS	POWER SUPPLY*	TRAVEL SPEED (FPM)	ADJUSTMENT FOR STD. S BEAMS			MINIMUM RADIUS CURVE (IN.)	APPROX. SHIPPING WEIGHT
						MOTOR H.P.	DEPTH (IN.)	FLANGE WIDTH (IN.)		
3670	63670	1/8	A	115-1-60			6	3-3/8		103
3671	63671	to	thru	230-3-60	75	1/4	thru	thru	30	112
3672	63672	2	RR	460-3-60			15	5-5/8		112
9577	69577			115-1-60			6	4		130
9578	69578	3	RT-RRT	230-3-60	75	1/4	thru	thru	30	130
9579	69579			460-3-60			15	5-5/8		130

*Trolleys are also available for operation on 573-3-60 and 220/380-3-50 power supply systems.

Table 2

Washer Spacing Chart

Chart A. 1/8 – 2-Ton Trolley

Standard Bracket (4-3/16" Wide)

Flange Width (in.)	NUMBER OF SPACER WASHERS			
	A	B	C	D
3-3/8	14	2	5	0
3-5/8	12	3	6	0
3-7/8	11	3	7	0
4	10	4	7	0
4-1/8	9	4	8	0
4-5/8	6	6	9	0
5	4	7	10	0
5-1/8	3	7	11	0
5-1/4	2	8	11	0
5-1/2	1	8	12	0
5-5/8	0	9	12	0

Special Load Bracket (6-11/16" Wide)

Flange Width (in.)	NUMBER OF SPACER WASHERS			
	A	B	C	D
5-5/8"	16	1	4	0
6"	14	2	5	0
6-1/4"	13	2	5	0
6-3/8"	12	3	6	0
6-1/2"	11	3	7	0
6-7/8"	9	4	8	0
7"	8	5	8	0
7-1/4"	7	4	9	0
7-3/8"	6	5	9	0
7-1/2"	5	6	10	0
7-7/8"	3	8	10	0
8"	2	8	11	0
8-1/4"	1	9	11	0
8-3/8"	0	9	12	0

Chart B. 3-Ton Trolley

Standard Bracket (4-13/16" Wide)

Flange Width (in.)	NUMBER OF SPACER WASHERS			
	A	B	C	D
4	13	1	4	0
4-5/8	9	3	6	0
5	7	4	7	0
5-1/4	5	5	8	0
5-1/2	4	5	9	0
5-5/8	3	6	9	0

Special Load Bracket (6-7/16" Wide)

Flange Width (in.)	NUMBER OF SPACER WASHERS			
	A	B	C	D
5-5/8	13	1	4	0
6	11	2	5	0
6-1/4	9	3	6	0
6-3/8	8	4	6	0
7	4	5	9	0
7-1/4	3	6	9	0

Special Load Bracket (6-7/16" Wide)

Flange Width (in.)	NUMBER OF SPACER WASHERS			
	A	B	C	D
7-1/2"	13	1	4	0
7-7/8"	11	2	5	0
8-1/8"	9	3	6	0
8 1/4"	8	4	6	0
8-7/8"	4	5	9	0
9-1/8"	3	6	9	0

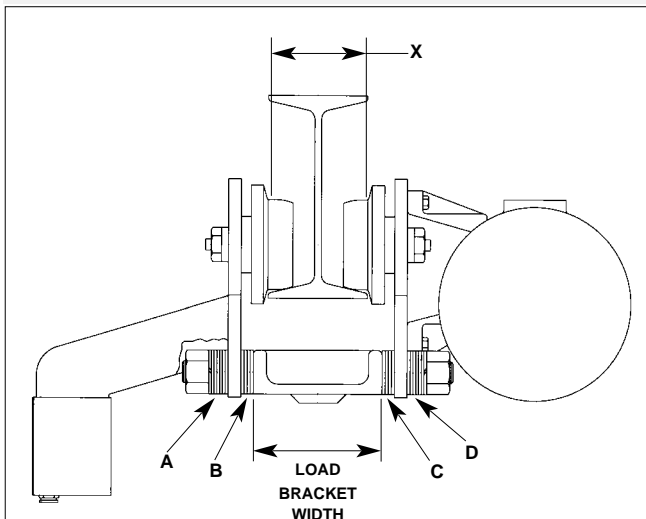

Figure 1. Trolley to Beam Installation

Due to the variations in beam flange widths, it is suggested that the beam flange width be measured to determine the exact distribution of spacer washers. The distance between trackwheel flanges (dimension "X") should be 1/8 to 3/16 inch greater than the beam flange width for straight runway beams, and 3/16 to 1/4 inch greater than the beam flange width if runway system includes sharp curves. Also, the use of other than CM supplied washers may result in trackwheel to beam flange variations and thus Table 2 will not apply.

WARNING

If CM's washer spacing recommendations are not followed, trolley may fall from beam.

TO AVOID INJURY:

Measure the actual beam flange on which the trolley is to operate and use Table 2 to determine the arrangement of the spacer washers for that flange width.

For the 3-Ton trolley, (refer to Figure 3), a shackle and pin assembly (627-729) consisting of a pin retained in a central position by retainers is packed loose with the suspension. Insert this assembly into the opening in the top of the load bracket (635-13) with the legs of the shackle down. Position the shackle pin in the groove provided for same in the load bracket making sure it is centered between the suspension bolts.

Now install the trolley (1/8 – 2-Ton or 3-Ton) on the beam by sliding one side frame out far enough to allow the trackwheels to clear the beam flange. Lift the trolley up so that the trackwheels are riding on the beam and draw the side frames together and tighten the nuts snugly. Do not overtighten the nuts. Insert the cotter pins through the slotted nuts and holes in the suspension bolts and spread the legs of the cotter pins to secure.

IMPORTANT: After the trolley is installed on the beam, remove the hex socket plug from the top of the gear reducer and replace same with the breather packed loose with the trolley or remove the small brass nail projecting from the side of the gear reducer. This provides a vent for the gear reducer and failure to install the breather may cause the seals to leak.

⚠ WARNING

An excessively worn beam flange may fail and allow the trolley to fall from the beam.

TO AVOID INJURY:

Periodically inspect the beam flange for wear. Replace beam if flange is worn.

Hoist to Trolley

On the 1/8 – 2-Ton trolley, assemble the suspension lug (on hoist) to the trolley (on beam) as shown in Figure 2. The lug is inserted in the trolley load bracket and retained by the suspension lug pin. A socket head cap screw and lockwasher are used to keep the pin in place. This assembly must be made with the hoist mounted parallel to the beam and the control cord to the right when facing the trolley control box.

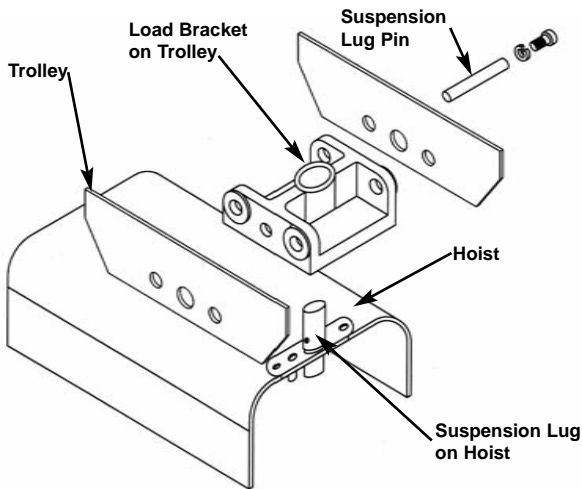

Figure 2. 1/8 – 2-Ton Hoist to Trolley Assembly

On the 3-Ton trolley, drive one retaining pin into the hole on one end of the lug pin (627-730). Raise the hoist into position so that the lug (627-728) is between the legs of the shackle. Align the holes in the shackle and lug. Insert the lug pin in the aligned holes and secure the lug pin by driving the remaining retaining pin into the hole in the lug pin. Make certain that the shackle pin (627-729) is properly seated in the load bracket by manipulating the hoist and checking for freedom of movement (swinging) in both planes and all four directions.

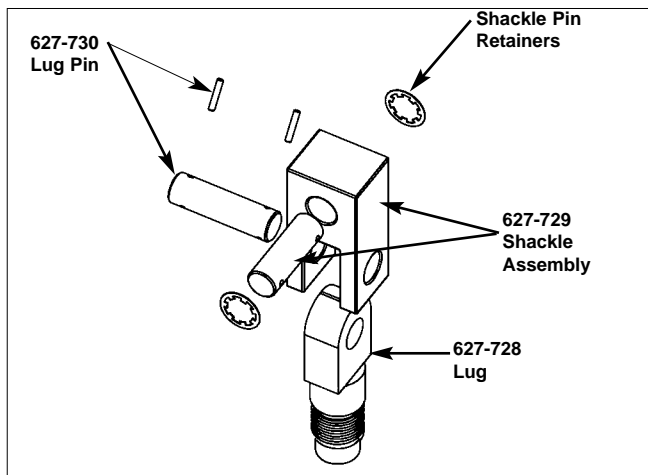

Figure 3. 3-Ton Hoist to Trolley Assembly
Note that the shackle pin should be retained and centered in the shackle with retainers.

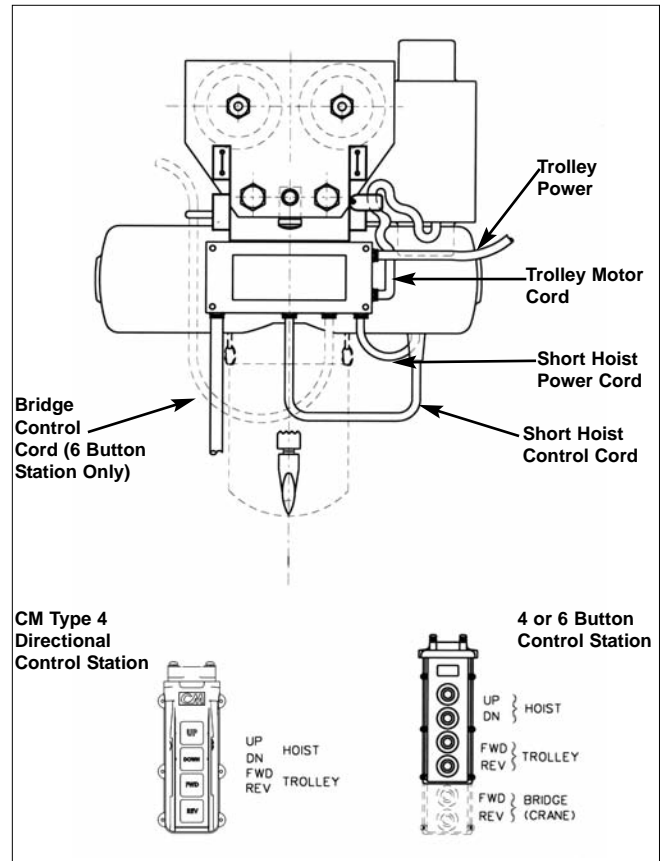

Figure 4. Hoist and Trolley General Arrangement

Electrical Installation

The trolley electrical connections must be completed as shown in Figure 4. Power to the trolley and hoist should be furnished from a compatible source through a disconnect device. Overcurrent protection and proper grounding means should be accomplished in accordance with the “National Electrical Code” and local codes if applicable. Power should be disconnected when making or changing connections. A Field Wiring Kit 635-198 (part number 36666 for units with 4-button control station) is furnished containing the necessary material to complete the trolley electrical connections.

Diagrams show connections to be made within trolley control box for standard units. For special units, see wiring diagram supplied with unit.

Trolley Motor Cord

Insert Trolley Motor Cord into control box (see Figure 4). Connections for the Trolley Motor Cord are shown in Figures 5 and 6. The cord should be brought over the top of the hoist and clamped to the control box mounting bracket (see Figure 4). The cord between the motor and clamp must be tight enough to prevent it from rubbing against the beam.

Trolley Power Cord

The short power cord furnished is for use with a collector and bus system. It should be discarded if a cable is to supply the trolley. Terminals for use on the trolley end of the supply cable are furnished in the Field Wiring Kit. Connections to the trolley are shown in Figures 5 and 6. The box connector must be made tight on the cable, and if necessary, a separate strain relief provided to prevent any stress on the terminals.

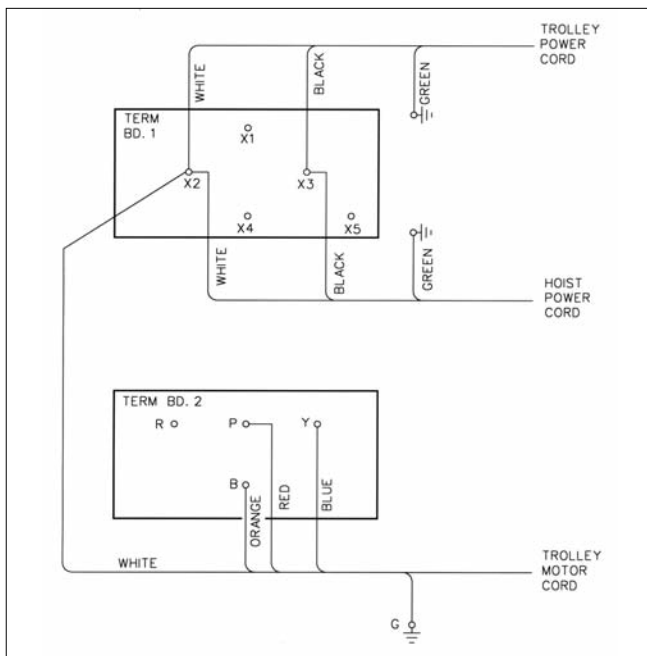

Figure 5. Hoist Power Cord Connections: Single-Phase

Hoist Power Cord

The trolley is supplied with a short hoist power cord connected into the power circuit of the trolley – refer to Figure 4. As a result, it is necessary to remove the power cord (if supplied – see note on page 6) from the hoist. To do this, remove the back frame cover (Lodestar and Valustar Hoists) from the hoist and remove and discard the power cord from the hoist. Then connect the short hoist power cord attached to the trolley to the hoist power circuit according to the wiring diagram furnished with the hoist. The trolley is also supplied with a short hoist control cord, and it should be connected to the hoist control circuit, as indicated below (see Hoist Control Cord) before the back frame cover (Lodestar and Valustar Hoists) is reassembled to the hoist frame.

Control Station

The standard trolleys for use with Lodestar and Valustar Hoists are supplied with a four directional control station.

Unless ordered special, the control station is suspended from the trolley control box by a cord that is approximately 16' – 3" long. If this is too long for your application, the cord should be shortened so that the control station is suspended approximately four feet above the operating floor.

WARNING

Tying knots or loops to shorten the drop of the control station will make the strain relief ineffective and the internal conductors of the cord may break.

TO AVOID PROBLEMS:

Shorten the control cord per the following instructions.

To shorten the cord, measure the distance the control station is to be raised. Disconnect the trolley from the power supply system. Remove the cover from the control station and disconnect the conductors of the control cord from the various terminals. For cords with the internal type strain relief, disconnect the strain relief loop from the control station housing and retain the strain relief screw, washer and the terminal block

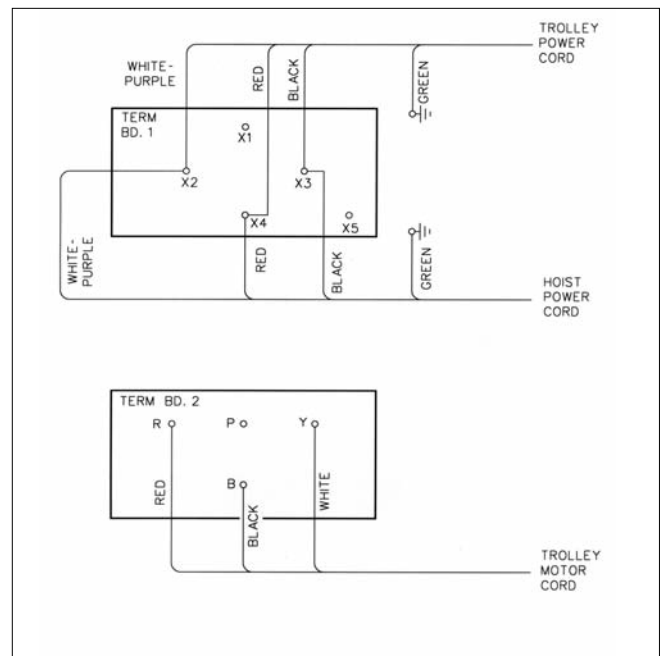
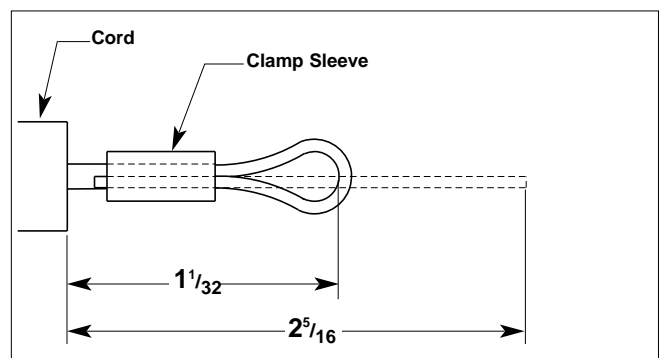

Figure 6. Hoist Power Cord Connections: Three-Phase

tab. For cords with the external, chain strain relief, disconnect the chain from the control station by twisting open the link. Measuring from the end of the longest conductor, cut-off the cord the distance the control is to be raised. Using the cut-off piece of cord as an example, prepare the end of the shortened cord. For cords with the internal type strain relief, prepare the strain relief loop as shown below.



Note: Conductors not shown for clarity.

Be sure to firmly squeeze the clamp sleeve (from the field wiring kit) using a vise or very large pliers to secure the loop end and insulate the clamp sleeve using the rubber sleeve from the cut-off piece of cord.

For units with external chain strain relief, cut-off the chain the distance the control station is to be raised.

Slide the prepared cord thru the grommet or box connector on top of the control station. Using the wiring diagram supplied with the trolley, connect the conductors of the control cord to the various terminals. For units with the internal type strain relief, attach the loop to the control station housing using the screw washer and the terminal block tab. For units with external type chain strain relief, attach the chain to the control station by re-closing the link. On these units, also firmly tighten the top ring of the box connector to seal the opening between the cord and the grommet.

Re-attach the cover to the control station. Energize the power supply system and test the trolley and hoist for proper operation.

NOTE: The four-directional control station can only be used with a hoist that has a reversing contactor. If the trolley and hoist is shipped direct from the factory, the hoist may not be equipped with the normal power cord or control station and cord assembly. As a result, these items will not have to be removed as indicated and the short hoist power and control cord on the hoist can be wired directly into the trolley. Use the wiring diagram supplied with the trolley for making the connections.

Hoist Control Cord

It is necessary to remove the control station (if supplied – see note above) from the hoist since the trolley is supplied with a short hoist control cord. Remove the control station and control cord assembly from the hoist. Connect the short hoist control cord from the trolley to the hoist control circuit following the wiring diagram supplied with the hoist. After this is completed, re-assemble the Back Frame Cover to the hoist frame.

The single-phase units are now ready for operation. However, on the three-phase units, the direction of trolley and hook travel must be checked (as indicated below) before the unit is put into service.

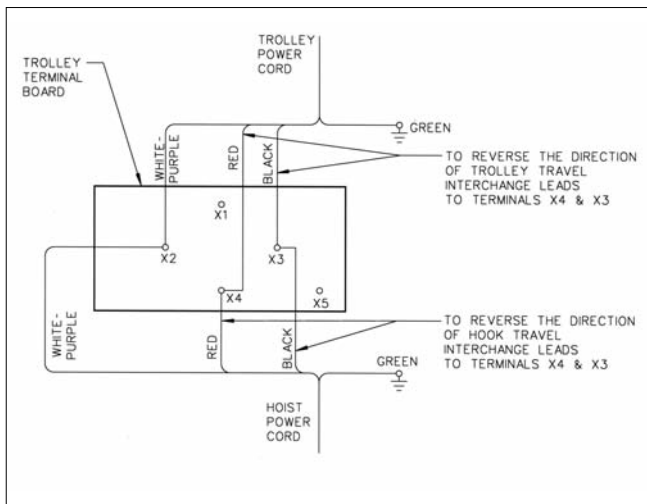

Figure 7. Connections for Proper Hook and Trolley Travel.

Three-Phase Units

A three-phase motor can rotate in either direction depending on its connection to the power supply. Therefore, the direction of trolley and hook travel relative to the selected indicated direction must be checked before the unit is put in service. If the hoist is incorrectly phased, the limit switches are ineffective and serious damage can result. Refer to hoist manual. The trolley should be checked out first, then the hoist. See Figure 7.

OPERATING INSTRUCTIONS

After the trolley and hook travel directions are correct, operate the trolley (according to the operating and safety procedures – see page ii) with a capacity load over the entire length of the runway or monorail system to be sure that all adjustments and operations are satisfactory.

The hoist/trolley combination is not ready for service and it should be moved forward by operating the controls marked →(Forward) and ←(Reverse) in control station. Unless altered by the erector, depressing →(Forward) control will move the hoist toward motor housing end. Anticipate the stopping point and allow trolley to coast to a smooth stop. Reversing or “plugging” to stop trolley causes overheating of motor and swaying of load.

INSPECTION

To maintain continuous and satisfactory operation, a regular periodic inspection procedure must be initiated so that worn or damaged parts can be replaced before they become unsafe. The frequency of inspection must be determined by the individual application.

The following list gives an inspection procedure for normal usage under normal conditions. When the unit is subjected to heavy usage or dusty, gritty, moist or other adverse atmospheric conditions, shorter time periods must be assigned. Inspection must be made of all parts for unusual wear, corrosion or damage in addition to those specifically mentioned in the list below.

It is suggested that the unit be inspected monthly for wear damage and corrosion effects to all parts with particular attention to the following:

1. Tightness of all fasteners including trackwheel stud nuts and suspension bolt nuts.
2. Contactor and control station for burnt or pitted contacts and loose or corroded terminals.
3. Cables and leads for broken wires, loose or corroded terminals, also damaged insulation.
4. Terminal board for loose or corroded connections.
5. Trackwheels for wear of tread and flange and for bearing wear as indicated by excessive looseness of wheel on stud.
6. Trackwheel gear, pinion and pinion bearing for wear.
7. On the 1/8 – 2-Ton trolley, check suspension lug, load bracket, suspension adapter and suspension lug pin for excess wear by manipulating hoist and visually inspecting suspension parts.
8. On the 3-Ton trolleys, check shackle pin for proper seating in groove of load bracket.

Manipulate hoist and check for freedom of movement (swinging) in both planes and all four directions. Also examine the shackle, shackle pin, suspension lug pin retaining pins, sheave stud and suspension adapter for excess wear by manipulating hoist and visually inspecting suspension parts.

9. Collector or power supply system for damage, wear corrosion and proper operation.
10. On trolleys equipped with the optional motor brake, check for friction disc wear and proper adjustment of the solenoid air gap.

MAINTENANCE

Once a month lubricate trackwheel gear and pinion with Texaco Novatex #2 or an equivalent heavy cup grease or graphite grease.

Motor gear box oil must be changed after the first 100 hours of operation, then every six months or 2500 hours of normal service, whichever comes first. Use 1/2 pint of Mobile SHC-626 or equal lubricant, for each oil change.

All other trolley parts and lubricated for life at the factory.



WARNING

The lubricants used in and recommended for the Series 635 Motor Driven Trolley may contain hazardous materials that mandate specific handling and disposal procedures.

TO AVOID CONTACT AND CONTAMINATION:

Handle and dispose of lubricants only as directed in applicable material safety data sheets and in accordance with applicable local, state and federal regulations.

IMPORTANT: Refer to manual packed with the hoist for the inspection and maintenance of the hoist.

MOTOR BRAKE (OPTIONAL EQUIPMENT)

A motor brake is available as optional equipment. The brake can be ordered with the trolley or it is available in kit form for installation on a unit in the field. To order a brake kit for an existing unit, order brake kit Key No. 635-287 and indicate the serial number of the trolley on which it is to be installed and the voltage on which the trolley operates.

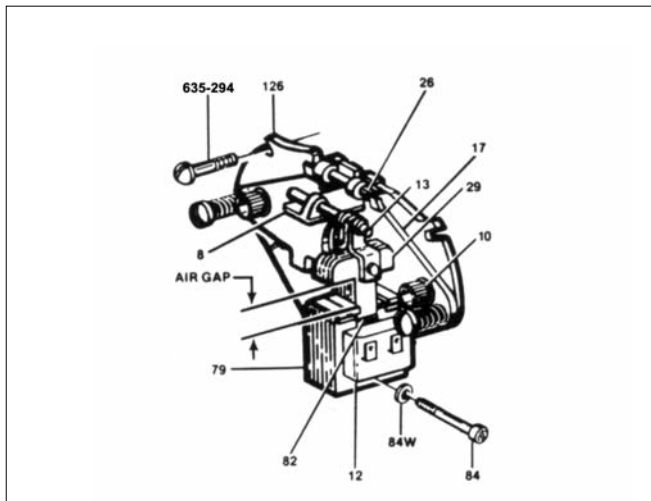

Figure 8. Motor Brake Adjustment.

Adjustment

The motor brake should be checked periodically for wear of the friction discs and/or proper adjustment of the solenoid air gap. Refer to Figure 8. Normal lining wear will cause the solenoid lever (8) to move away from the solenoid frame (79) and thus increase the air gap and trolley stopping time.

When the gap reaches approximately 11/16" the brake should be adjusted. To adjust the brake, de-energize the power supply to the trolley.

Remove both access covers to expose the brake. Depress the plunger (13) towards the solenoid frame until spring pres-

sure is felt. Hold the plunger firmly in this position and measure the air gap between the mating (ground) surfaces of the solenoid (79) and the solenoid plunger (29). To adjust, turn both wear adjustment screws (10) equal amounts clockwise until the air gap measures 13/32".



WARNING

Working in or near exposed energized electrical equipment presents the danger of electric shock.

TO AVOID INJURY:

DISCONNECT POWER AND LOCKOUT/TAGOUT DISCONNECTING MEANS BEFORE REMOVING COVER OR SERVICING THIS EQUIPMENT.

REPLACEMENT OF FRICTION DISC

(Refer to Figure 16, page 18)

1. De-energize the power supply to the trolley and remove the motor/brake assembly from the gear reducer. Remove housing (635-261) from the brake.
2. Remove the entire support plate assembly by unscrewing three (3) screws (635-294). Remove the stationary disc (635-269) and worn friction disc (635-270). Install the new friction disc, making sure that the two stabilizing springs are at 90° in the recessed portion of the square hole in the friction disc, with the prongs pointing into the brake. Place the stationary disc on the friction disc and re-assemble the entire support plate assembly engages the guide pins of the end plate.
3. Remove both access covers (635-263) from the housing (635-261) and slide the housing with its shaft assembly onto the mounting studs. Be sure the housing is assembled with the access windows above the horizontal centerline. Rotate shaft to engage key into the hub keyway.
4. Re-assemble the motor/brake assembly to the gear reducer using the four nuts and lockwashers.
5. Adjust air gap per above instructions(adjustment).
6. Re-energize power supply and operate trolley a few times to make sure air gap is correct and then replace access covers (635-263).

REPLACEMENT OF COIL

(Refer to Figure 8 on this page and Figure 15 on page 17)

1. De-energize the power supply to the trolley and remove the motor/brake assembly from the gear reducer.
2. Remove housing (635-261) from the brake and disconnect the coil lead wires from brake cord.
3. Insert screwdriver between support plate (126) and the top of lever arm (17). Wedge these apart and remove bearing pin (26) and solenoid lever (8) with link (13) and plunger (29).
4. Remove plunger guide screw (84) and both plunger guides (82). Slide old coil sideways out of frame (79). If coil is difficult to move, tap lightly with a soft hammer.
5. Install new coil in the same relative position as the old coil and replace the plunger guides (82) and screws (84, 84W).
6. Re-assemble following Step 3 in reverse order.
7. Re-connect the coil leads to the brake cord. Slide housing and shaft assembly onto mounting studs, rotating shaft to engage key into hub keyway. Be sure the access covers are above the horizontal centerline.

8. Re-assemble motor/brake assembly to gear reducer using the four nuts and lockwashers.
9. Adjust air gap per above instructions (Adjustment).
10. Re-energize power supply and operate trolley a few times to make sure air gap is correct and then replace access covers.

RECOMMENDED SPARE PARTS

To insure continued operation of the Series 635 Motor Driven Trolleys, the following is a list of parts that are recommended to be kept on hand at all times to replace parts that have worn or failed:

Key No.	Part Name	Qty. for each Trolley in Service
635-45	Transformer (3-phase units only)	1
635-126	Contacto	1
635-156	Control Station	
635-286	Coil Kit (for units equipped with brake)	1

Refer to page 11 for ordering information and the parts lists for the part numbers.

TROUBLESHOOTING

ELECTRICAL DATA

To detect open and short circuits in electrical components, use the following procedure.

OPEN CIRCUITS in the coils of electrical components may be detected by isolating the coil and checking for continuity with an ohmmeter or with the component in series with a light or bell circuit.

SHORTED TURNS are indicated by a current draw substantially above normal (connect ammeter in series with suspected element and impose normal voltage) or D.C. resistance substantially below normal. The current method is recommended for coils with very low D.C. resistance

MOTOR CURRENT should be measured with the motor running under full load with rated voltage applied.

CONTACTOR COIL CURRENT should be measured with the contactor armature (contacts) closed and full voltage on the coil.

Table 3

Electrical Data for Trolley Components

MOTORS			
Voltage-Phase Hertz	Full Load Current (Amps.)	Leads	D.C. Resistance (Ohms)
115-1-60/50	3.4/4.2	1 - 3	3.3
		2 - 3	3.1
230/460-3-60	1.3/.65	1 - 4	15.3
		2 - 5	15.3
		3 - 6	15.3
		7 - 8	30.5
		7 - 9	30.5
		8 - 9	30.5
220/380-3-50	1.7/.85	1 - 4	15.3
		2 - 5	15.3
		3 - 6	15.3
		7 - 8	30.5
		7 - 9	30.5
		8 - 9	30.5
575-3-60	.52	1 - 2	95.0
		1 - 3	95.0
		2 - 3	95.0

TRANSFORMER		
Voltage	Leads	D.C. Resistance (Ohms)
230/460	H4 to H3	150
	H1 to H2	150
115	X1 to X2	21

CONTACTOR COIL		
Voltage Hertz	Current (Amps)	D.C. Resistance (Ohms)
120-60	0.10	150
110-50	0.12	210
115-60/50	.124/.140	132

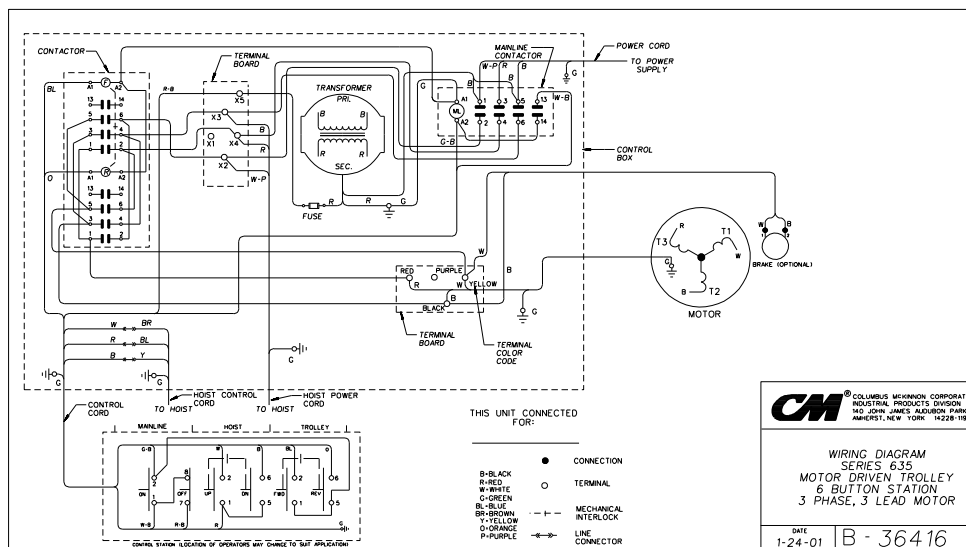
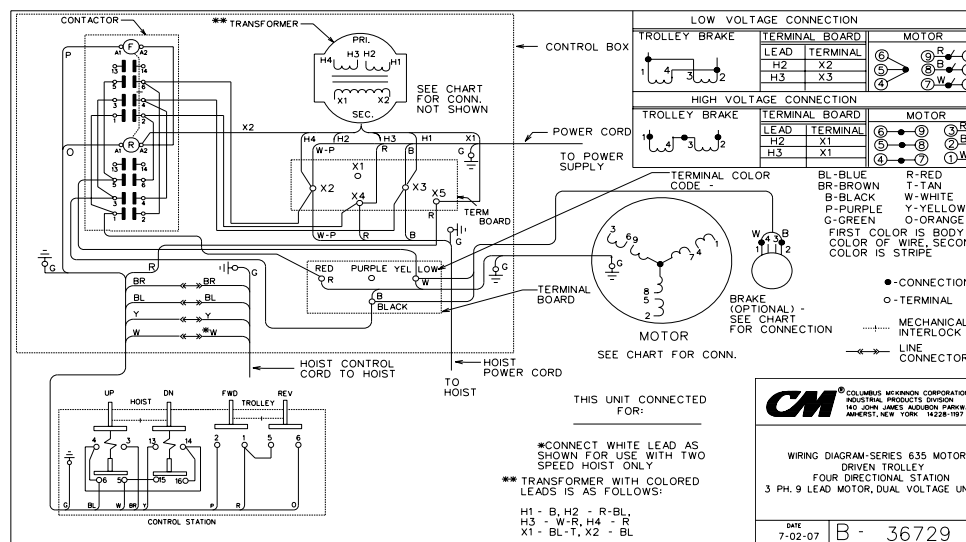
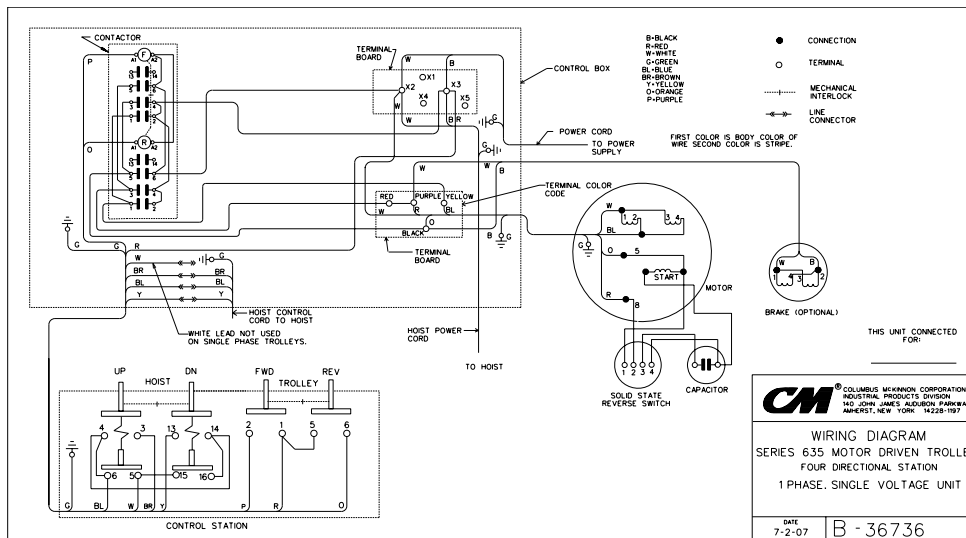

Figure 9. Typical Wiring Diagrams. Wiring Diagrams shown are representative. Consult diagram attached to contactor or furnished with unit.

TROUBLE SHOOTING

— Probable Cause —

— Remedy —

1. Trolley does not operate in either direction.

<p>A. No voltage at trolley</p> <p>B. Phase failure (single-phasing)</p> <p>C. Open control circuit</p> <p>D. Wrong voltage or frequency</p> <p>E. Low voltage</p> <p>F. Excessive load</p>	<p>A. Main line or branch circuit switch open; branch line fuse blown or circuit breaker tripped. Close, replace or reset. Check for grounded or open connection in supply lines or current collectors.</p> <p>B. Open circuit, grounded or open connection in one line of supply system, collectors, hoist wiring, reversing contactor, motor leads or windings. Check for electrical continuity.</p> <p>C. Open or shorted windings in transformer or reversing contactor coil; loose connection or broken wire in circuit; mechanical binding in contactor; control station contacts not making.</p> <p>D. The voltage and frequency must be the same as shown on trolley control box.</p> <p>E. Voltage at the motor must be above the minimum with the unit in operation:</p> <table style="margin-left: auto; margin-right: auto; border: none;"> <thead> <tr> <th style="text-align: center; border-bottom: 1px solid black;">UNIT RATING</th> <th style="text-align: center; border-bottom: 1px solid black;">MINIMUM VOLTAGE</th> </tr> </thead> <tbody> <tr> <td style="text-align: center;">110-120/1/60</td> <td style="text-align: center;">99</td> </tr> <tr> <td style="text-align: center;">208-240/3/60</td> <td style="text-align: center;">187</td> </tr> <tr> <td style="text-align: center;">440-480/3/60</td> <td style="text-align: center;">396</td> </tr> <tr> <td style="text-align: center;">220/3/50</td> <td style="text-align: center;">198</td> </tr> <tr> <td style="text-align: center;">380/3/50</td> <td style="text-align: center;">342</td> </tr> <tr> <td style="text-align: center;">575/3/60</td> <td style="text-align: center;">517</td> </tr> </tbody> </table> <p>F. Reduce loading to the capacity limit of trolley.</p>	UNIT RATING	MINIMUM VOLTAGE	110-120/1/60	99	208-240/3/60	187	440-480/3/60	396	220/3/50	198	380/3/50	342	575/3/60	517
UNIT RATING	MINIMUM VOLTAGE														
110-120/1/60	99														
208-240/3/60	187														
440-480/3/60	396														
220/3/50	198														
380/3/50	342														
575/3/60	517														

2. Trolley operates in one direction only.

A. Open control circuit	A. See Item 1c.
-------------------------	-----------------

3. Trolley operates sluggishly.

A. Excessive load	A. See Item 1f.
B. Low voltage	B. See Item 1e.
C. Worn or dirty rails	C. Clean rails, inspect for worn spots.

4. Motor overheats.

A. Excessive load	A. See Item 1f.
B. Low voltage	B. See Item 1e.
C. Extreme external heating	C. Above an ambient temperature of 104°F., the frequency of trolley operation must be limited to avoid overheating of motor. Special provision should be made to ventilate the space or shield the trolley from heat radiation. Excessive inching, jogging or plugging should be avoided since this type of operation will drastically shorten the life of motor and contactor. See Item 1b.

REPLACEMENT PARTS

ORDERING INSTRUCTIONS

The following information must accompany all correspondence or orders for replacement parts:

1. Serial number – this is stamped on the side frame above the motor mounting, as shown below.
2. Voltage, Phase, Hertz – see the labels located next to the power cord and on the inside of the control box cover.

When ordering motor parts, give the motor name plate data in addition to the above.

For parts orders also specify:

1. Quantity desired.
2. Key number or part.
3. Part name.
4. Part number.

Parts should be ordered from CM's authorized Master Parts Depots conveniently located throughout the United States and Canada. Refer to page i of this manual to locate the Master Parts Depot nearest you.

NOTE: When ordering replacement parts, it is recommended that consideration be given to the need for also ordering such items as bearings, contacts, fasteners, etc. These items may be damaged or lost during disassembly or just unfit for future use because of deterioration from age or service.

! WARNING

Using "commercial" or other manufacturer's parts to repair the Series 635 Motor Driven Trolley may cause load loss.

TO AVOID INJURY:

Use only CM supplied replacement parts. Parts may look alike, but CM parts are made of specific materials or processed to achieve specific properties.

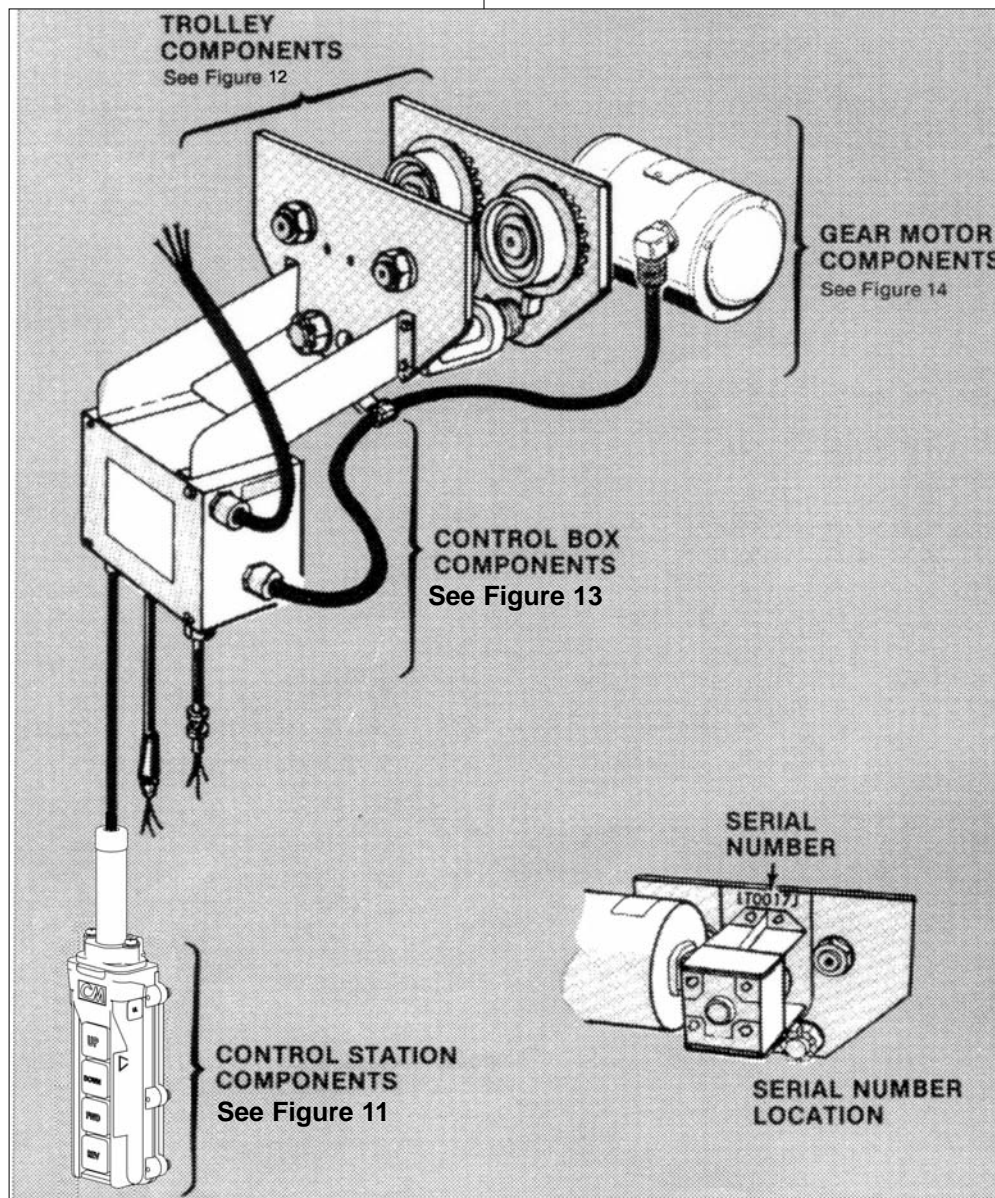
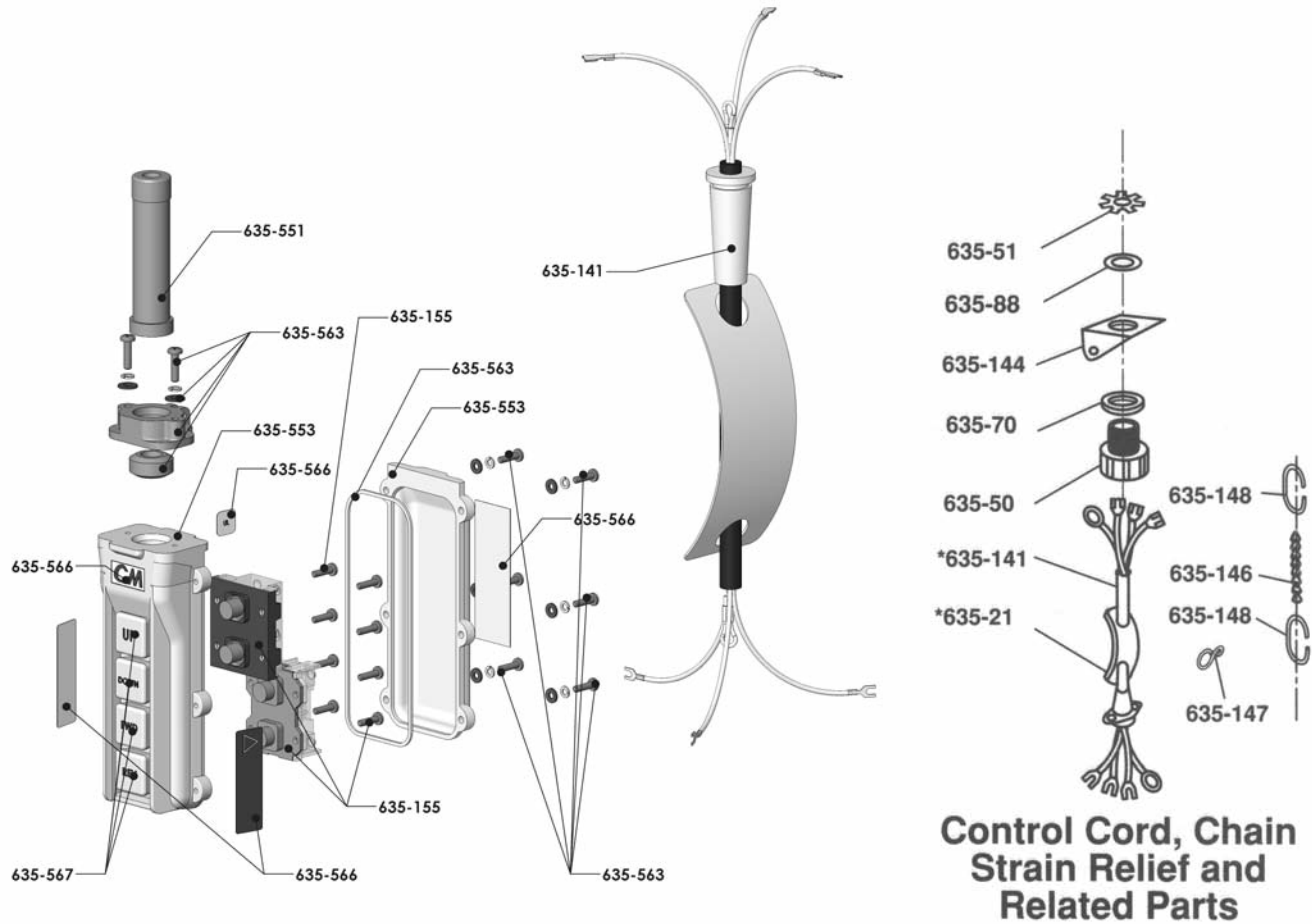

Figure 10. Trolley Arrangement

CM® 4 DIRECTIONAL CONTROL STATION PARTS LIST



Control Cord, Chain Strain Relief and Related Parts

***Refer to parts list on page 15 for information on these parts**

Key No.	Part Name	No. Req'd.	Part No.
635-21	Warning Tag	1	81704
635-141	Control Cord Complete (Specify Length Required.) 8 Conductors, 16'-3" All others Consists of (1) Control Cord and (1) Warning Tag	1	51708 Contact Factory
635-144	Chain Clip at Control Box 8 Conductors 10 Conductors	1	68704 57817
635-146	Control Station Support Chain (Specify Length Required.)	-	621431
635-147	Cable Clip (Specify Number Required.)	1	20744
635-148	Support Chain Attaching Link	2	59883
635-155	Control Station Inserts 1-Speed Inserts 2-Speed Inserts	1 1	58255 58256
635-156	Control Station Complete 4 Button Control Station 6-Button Control Station	1 1	58220CM 58252
635-551	Control Station Grommet	1	58278
635-553	Control Station Housing Kit (Includes Housing, Boots, Collar Gasket & Hardware)	1	58288
635-563	Control Station Hardware Kit w/Gaskets	1	58279
635-566	Control Station Warning Label Kit	1	58276
635-567	Control Station Button Label Kit	1	58277

Figure 11

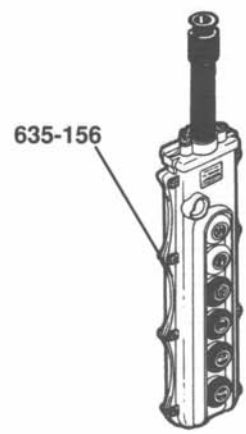

6-Button Control Station- Individual components not available for repair

Multifunction Control Stations

TROLLEY COMPONENTS PARTS LIST

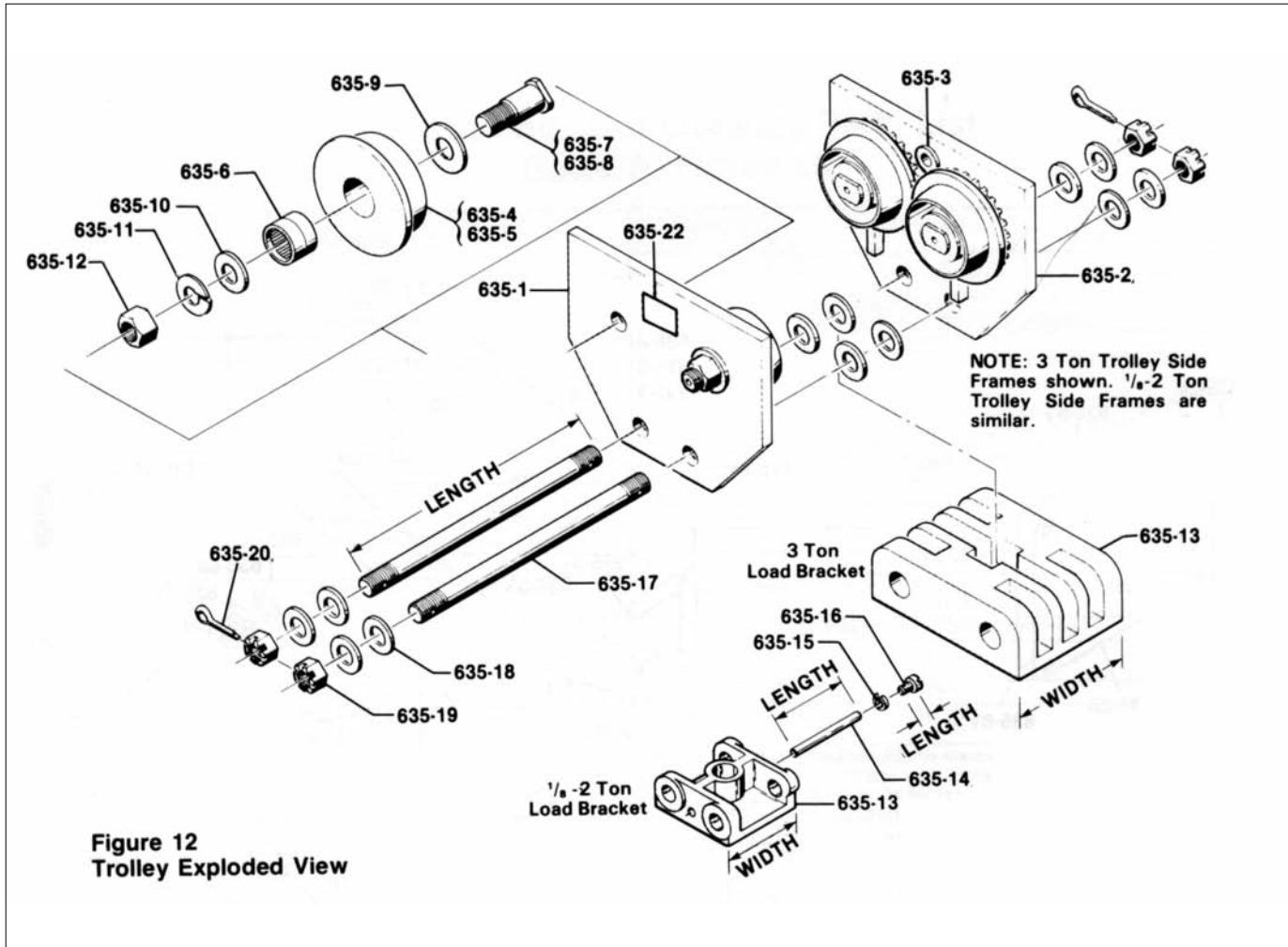

Figure 12
Trolley Exploded View

Figure 12. Trolley Exploded View.

Key No.	Part Name	No. Req'd.	Part No. 1/8 – 2-Ton	Part No. 3-Ton
635-1*	Side Frame – Plain Side (Does not include wheels)	1		
	3-3/8" thru 5 5/8" Flange Range		35680	-
	5-5/8" thru 8 3/8" Flange Range		35680	-
	4" thru 5 5/8" Flange Range		-	36696
	5-5/8" thru 7-1/4" Flange Range		-	35523
	7-1/2" thru 9-1/8" Flange Range		-	35682
635-2*	Side Frame – Geared Side (Does not include wheels)	1	35690	-
	3-3/8" thru 5-5/8" Flange Range		35690	-
	5-5/8" thru 8-3/8" Flange Range		-	36696
	4" thru 5-5/8" Flange Range		-	36696
	5-5/8" thru 7-1/4" Flange Range		-	35665
	7-1/2" thru 9-1/8" Flange Range		-	35665
635-3	Motor Shaft Bearing	1	82055	82055
635-4	Trackwheel Plain	2	39002	39002
635-5	Trackwheel with Gear	2	35642	35642
635-6	Trackwheel Bearing	4	82113	82113
635-7	Trackwheel Stud – Plain Wheel	2	36361	36361
635-8	Trackwheel Stud – Geared Wheel	2	36362	36362
635-9	Trackwheel Washer – Steel	4	81014	81014
635-10	Trackwheel Washer – Oilite	4	82046	82046
635-11	Trackwheel Stud Lockwasher	4	987926	987926
635-12	Trackwheel Stud Nut	4	988155	988155

Key No.	Part Name	No. Req'd.	Part No. 1/8 – 2-Ton	Part No. 3-Ton
635-13	Load Bracket- (FR = Flange Range)	1		
	3-3/8" thru 5-5/8" F.R. (4-3/16" wide)		35033	-
	5-5/8" thru 8-3/8" F.R. (6-1/16" wide)		35043	-
	4" thru 5-5/8" F.R. (4-13/16" wide)		-	36012
	5-5/8" thru 7-1/4" F.R. (6-7/16" wide)		-	36021
	7-1/2" thru 9-1/8" F.R. (6-7/16" wide)		-	36021
635-14	Suspension Lug Pin	1		
	2-7/8" long		35413	-
	3-3/4" long		35400	-
635-15	Suspension Lug Pin Screw Washer	1	983547	-
635-16	Suspension Lug Pin Screw	1		
	3/4" long		982433	-
	1-1/2" long		987209	-
635-17	Suspension Bolt-(FR=Flange Range)	2		
	3-3/8" thru 5-5/8" F.R. 1" dia. x 10-23/32" long		35446	-
	5-5/8" thru 8-3/8" F.R. 1" dia. x 13-1/4" long		35430	-
	4" thru 5-5/8" F.R. 1-1/4" dia. x 11-15/32" long		-	36358
	5-5/8" thru 7-1/4" F.R. 1-1/4" dia. x 12-31/32" long		-	36380
	7-1/2" thru 9-1/8" F.R. 1-1/4" dia. x 15-15/32" long		-	35187
635-18	Spacer Washer			
	42		981012	-
	36		-	936827
635-19	Suspension Bolt Nut	4	958818	945835
635-20	Suspension Bolt Cotter Pin	4	988368	988382
635-22	Warning Label	1	936984	936984

* For Trolleys with standard ranges of adjustment and without trolley guards.
For all others, contact CM for side frame part numbers.

CONTROL BOX COMPONENTS PARTS LIST

Key No.	Part Name	No. Req'd.	Part No. 1/8 - 2-Ton, 3-Ton
635-26	Control Box & Brackets w/ Cover and Cover Mounting Screws Units w/o Main Line Contactor Units w/ Main Line Contactor	1	36801 36248
635-29	Control Box Mounting Screw	4	982693
635-30	C.M. Nameplate	1	935899 936828 (1/8 - 2-Ton) (3-Ton)
635-31	Wiring Diagram	1	Contact CM
635-32	Current Label 115-1-60 230-3-60 460-3-60 220-3-50 380-3-50 Blank	2	935884 935885 935886 935887 935888 935889
635-33	Strain Relief Screw	1	982695
635-34	Strain Relief Screw Washer	2	954802
635-35	Cable Clamp	1	27833
635-36	Cable Clamp Screw Washer	1	954802
635-37	Cable Clamp Screw	1	982688
635-38	Power Cord (Specify Length) Single-Phase Three-Phase Units w/ Main Line Contactor	1	51436 51434 See pg. 15
635-39	Power Cord Connector Single-Phase Three-Phase	1	89926 89916
635-40	Power Cord Connector Locknut	1	989771
635-43	Hoist Power Cord Connector	1	89916
635-44	Hoist Power Cord Connector Locknut	1	989771
635-45	Transformer (See Units with Main Line Contactor) 230-3-60 & 460-3-60 Trolleys (115 V. ctrl.) 220-3-50 & 380-3-50 Trolleys (48 V. ctrl.) 230, 220, 380 & 460 Trolleys (24 V. ctrl.) 575-3-60 Trolleys (115 V. ctrl.) 115-1-60 Trolleys (48 V. ctrl.) 115-1-60 Trolleys (24 V. ctrl.)	1	36412 36413 35809 35807 36753 35810
635-46	Transformer Mounting Screw	2	982686
635-47	Terminal Board	1	35880
635-48	Terminal Board Mounting Screw Single-Phase Three-Phase	2	982684 982537
635-49	Terminal Board Mounting Screw Nut	2	988101
635-50	Control Cord Connector 8 Conductors 10 Conductors	2	983979 83982
635-51	Control Cord Connector Locknut 8 Conductors 10 Conductors	1	989772 989773
635-53	Contact Mounting Screw & Lockwasher Screw Lockwasher	- 2 2	957854 957855
635-54	Jumper - (No. Req'd.) followed by Part No. Single-Phase Three-Phase	(2)35382, (1)35386, (1)35388, (1)35387 (1)35376, (1)35377, (1)35378, (1)35387, (1)35386, (1) 35388	
635-55	Jumper (Between Coil Terminals)	1	51487
635-58	Term. Bd. Nut	2	982484
635-59	Term. Bd. Motor Cable	2	28719
635-61*	Cover Gasket	1	35941
635-65	Motor Cable Connector	1	89916
635-66*	Motor Cable Connector "O" Ring	1	983967
635-67	Motor Cable Connector Locknut	1	989771
635-68*	Power Cord Connector "O" Ring	1	983967

Key No.	Part Name	No. Req'd.	Part No. 1/8 - 2-Ton, 3-Ton
635-69*	Hoist Power Cord Connector "O" Ring	1	983967
635-70*	Control Cord Connector "O" Ring 8 Conductors 10 Conductors	1	983963 984901
635-71*	Control Box Plug Screw Single-Phase Three-Phase	2	982686 982683
635-72*	Gasket Cement	1	986913
635-76	Hoist Control Cord Connector	1	89926
635-77*	Hoist Control Cord Connector "O" Ring	1	983967
635-78	Hoist Control Cord Connector Locknut	1	989771
635-79~	Bridge Control Cord (Specify Length Required)	1	89683
635-80~	Bridge Control Cord Connector	1	83980
635-81*~	Bridge Control Cord Connector "O" Ring	1	983963
635-82~	Bridge Control Cord Connector Locknut	1	989772
635-83~	Cable Clamp Screw Nut	1	982514
635-84~	Cable Clamp	1	27833
635-85~	Cable Clamp Screw Washer	1	954802
635-86~	Cable Clamp Screw	1	982688
635-87	Label (For Wiring Diagram)	1	968996
635-88	Connector Washer (Control Box Part No. 36801)	1	987177
635-126†	Contact 115 V. Coils (Three Phase) 48 V. Coils (Three Phase) 24 V. Coils (Three Phase) 115 V. Coils 48 V. Coils 24 V. Coils	1 1 1 1 1 1	24799 24797 28860 28553 28545 28552
635-197‡	Field Wiring Kit (2-Button Control Station)	1	36665
635-198‡	Field Wiring Kit (4-Button Control Station)	1	36666
635-217	Ground Screw	3	958805
635-218	Ground Screw Lockwasher	3	987873
635-223	Short Hoist Power Cord Single-Phase Lodestar Three-Phase Lodestar Valustar	1	27759 28546 Contact CM
635-224	Short Hoist Control Cord Lodestar (Single Phase) Lodestar (Three Phase) Valustar	1	51131 51130 Contact CM
635-300	Line Connector (Specify Number Required)	-	982158
635-304	Brake Cord Connector Locknut	1	989771
635-305*	Brake Cord Connector "O" Ring	1	983967
635-306	Brake Cord Connector	1	89916

UNITS WITH MAIN LINE CONTACTOR

Key No.	Part Name	No. Req'd.	Part No.
635-45	Transformer W/Fuse 230 Volt & 460 Volt (115 V. Control) 575 Volt (115 V. Control) For Others	1	68659 68658 Contact CM
635-38	Power Cord Single-Phase Three-Phase	1	51201 51203
‡	Main Line Contactor (115 Volt) 3-Phase (48 Volt) 3-Phase (24 Volt) 3 Phase (115 Volt) 1-Phase (48 Volt) 1-Phase (24 Volt) 1-Phase	1 1 1 1 1 1	36947 35248 35249 28904 28903 28902
‡	Main Line Contactor Screw	2	987277
‡	Main Line Contactor Screw L.W.	2	957844
‡	Transformer Spacer	4	68759
‡	Transformer Mfg. Screw	4	959200
‡	Transformer Screw L.W.	4	987873

*For weatherproof units only

~For use with 6-Button Control Stations

†Individual components not available for repairs

‡Not shown

MOTOR AND HUB CITY TYPE GEAR REDUCER PARTS LIST

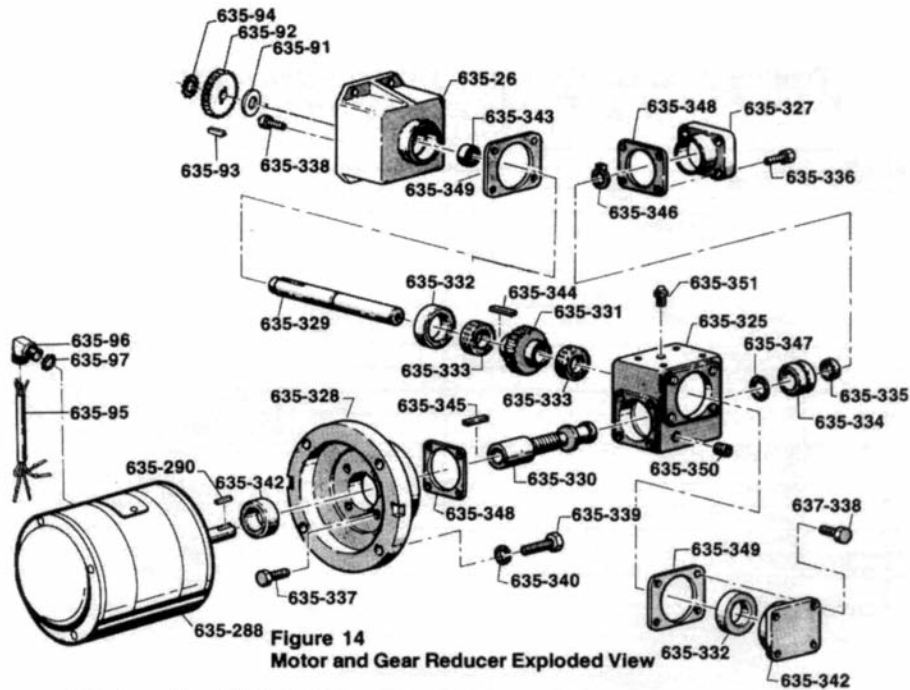

Figure 14. Motor and Hub City Type Gear Reducer Exploded View.

Key No.	Part Name	No. Req'd.	Part No.
635-89	Gear Reducer Mfg. Screw	4	927764
635-90	Gear Reducer Screw L.W.	4	982226
635-91	Pinion Washer	1	982263
635-92	Pinion	1	35429
635-93	Pinion Key	2	85546
635-94	Pinion Retaining Ring	1	82680
635-95	Motor Cable Assembly Single-Phase Three-Phase	1	36500 51440
635-96	Motor Cable Connector Single-Phase Three-Phase	1	83969 83968
635-97	Connector Lockout	1	989771
635-288	Motor – Complete (Individual Components not available for repairs)	1	36925 36924 36926
635-289	Gear Reducer – Complete 75 F.P.M. Trolleys (10:1) 30 F.P.M. Trolleys (25:1)	1	36204 36205
635-290	Motor Shaft Key	1	85554
635-291	Motor Attaching Screw and Lockwasher	4 4	987005 987919
635-325	Housing	1	Contact CM
635-326	Cap, Output	2	Contact CM
635-327	Cap, Closed Input	1	Contact CM
635-328	Flange, Motor	1	Contact CM

Key No.	Part Name	No. Req'd.	Part No.
635-329	Shaft, Output	1	Contact CM
635-330	Worm, Integral	1	Contact CM
635-331	Gear, Worm	1	Contact CM
635-332	Cup, Bearing	2	Contact CM
635-333	Cone, Bearing	2	Contact CM
635-334	Bearing, Ball	1	Contact CM
635-335	Washer	1	Contact CM
635-336	Screw, Hex Cap (1/4 NC x 5/8-GR5)	4	Contact CM
635-337	Screw, Hex Cap (1/4 NC x 7/8-GR5)	4	Contact CM
635-338	Screw, Hex Cap (1/4 NC x 1/2-GR5)	8	Contact CM
635-339	Screw, Hex Cap (3/8 NC x 1-GR5)	4	Contact CM
635-340	Washer, Locking (3/8)	4	Contact CM
635-341	Kit, Repair (Includes 635-342 thru 635-351)	1	Contact CM
635-342*	Seal, Input Shaft	1	Contact CM
635-343*	Seal, Output Shaft	1	Contact CM
635-344*	Key, P&W (3/16 Sq. x 1")	1	Contact CM
635-345*	Key, P&W (3/16 Sq. x 1-3/8")	1	Contact CM
635-346*	Ring, Retaining	1	Contact CM
635-347*	Ring, Retaining	1	Contact CM
635-348*	Gasket, Input Cap	12	Contact CM
635-349*	Gasket, Output Cap	12	Contact CM
635-350*	Plug, Pipe, Socket (1/8 NPT)	4	Contact CM
635-351*	Plug, Vented	1	Contact CM
635-352	Cap, Closed	1	Contact CM

* These Items are only available in Repair Kit Form. Order "Kit, Repair, Key No. 635-341".

MOTOR BRAKE PARTS LIST

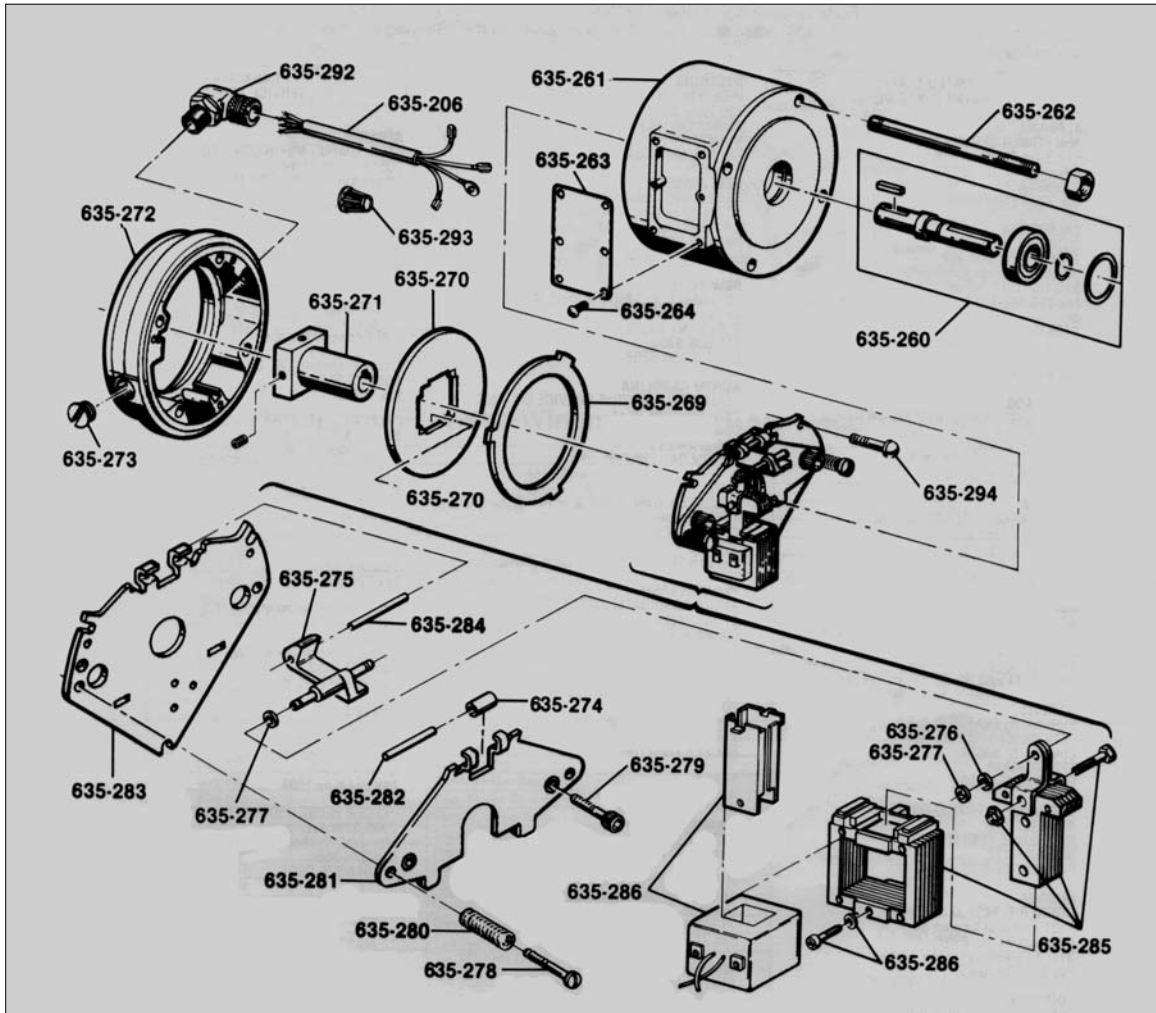

Figure 16. Motor Brake Exploded View.

Key No.	Part Name	No. Req'd.	Part No.
635-206	Brake Cord	1	51074
635-260	Coupler Brake Shaft Kit (Includes Shaft, Bearing, Snap Ring, Retainer Ring and Key)	1	Contact CM
635-261	Housing	1	Contact CM
635-262	Mounting Stud with Nut	4	Contact CM
635-263	Access Cover - Plain	2	Contact CM
635-264	Access Cover Screw (Specify No. Req'd.)	-	Contact CM
635-265*	Access Cover Gasket	2	Contact CM
635-266*	Drain Plug	1	Contact CM
635-267*	Housing to End Plate Gasket	1	Contact CM
635-268*	Gasket - Each End of Brake	2	Contact CM
635-269	Stationary Disc	1	Contact CM
635-270	Friction Disc Kit (Includes 3 Discs with Stabilizer Spring - Only one Disc required per Brake)	1	Contact CM
635-271	Hub Kit (Includes Hub and Set Screws)	1	Contact CM
635-272	End Plate Assembly	1	Contact CM
635-273	Plug - External Lead Hole	1	Contact CM
635-274	Bearing	1	Contact CM
635-275	Solenoid Lever	1	Contact CM
635-276	Retainer Ring	1	Contact CM
635-277	Spacer	2	Contact CM

Key No.	Part Name	No. Req'd.	Part No.
635-278	Torque Adjusting Screw	2	Contact CM
635-279	Wear Adjusting Screw	2	Contact CM
635-280	Pressure Spring	2	Contact CM
635-281	Lever Arm and Stop Nut Assembly	1	Contact CM
635-282	Bearing Pin	1	Contact CM
635-283	Support Plate and Stop Nut Assembly	1	Contact CM
635-284	Pivot Pin	1	Contact CM
635-285	Solenoid Kit (Includes Plunger, Link, Frame Link Screw, Link Nut and Mounting Screws)	1	Contact CM
635-286	Coil Kit (Includes Coil, Plunger Guides, Guide Screw and Lockwasher)	1	Contact CM
635-287	Motor Brake Kit (Includes Complete Brake Assembly, Brake Cord, Connector Wire Nuts and Installation Instructions)	1	
	115 Volt Brake		9597
	220, 230, 380, 460 Volt Brake		9598
635-292	Brake Cord Connector	1	83968
635-293	Wire Nut	4	982473
635-294	Brake Attaching Screw	3	Contact CM
635-353**	Access Cover (with Manual Release Knob)	1	Contact CM

*For Weatherproof Units - Not Shown

**Not Shown

NOTES



Note: When ordering parts, always furnish hoist model and serial number, motor horsepower, voltage, phase, frequency and rated capacity of hoist on which the parts are to be used. For the location of the nearest CM Master Parts Depot, see the list located on the inside front cover.

LIMITATION OF WARRANTIES, REMEDIES AND DAMAGES

THE WARRANTY STATED BELOW IS GIVEN IN PLACE OF ALL OTHER WARRANTIES, EXPRESS OR IMPLIED, OF MERCHANTABILITY, FITNESS FOR A PARTICULAR PURPOSE, OR OTHERWISE, NO PROMISE OR AFFIRMATION OF FACT MADE BY ANY AGENT OR REPRESENTATIVE OF SELLER SHALL CONSTITUTE A WARRANTY BY SELLER OR GIVE RISE TO ANY LIABILITY OR OBLIGATION.

Seller warrants that on the date of delivery to carrier the goods are free from defects in workmanship and materials.

SELLER'S SOLE OBLIGATION IN THE EVENT OF BREACH OF WARRANTY OR CONTRACT OR FOR NEGLIGENCE OR OTHERWISE WITH RESPECT TO GOODS SOLD SHALL BE EXCLUSIVELY LIMITED TO REPAIR OR REPLACEMENT, F.O.B. SELLER'S POINT OF SHIPMENT, OF ANY PARTS WHICH SELLER DETERMINES TO HAVE BEEN DEFECTIVE or if Seller determines that such repair or replacement is not feasible, to a refund of the purchase price upon return of the goods to Seller.

Any action against Seller for breach of warranty, negligence or otherwise, must be commenced within one year after such cause of action occurs.

NO CLAIM AGAINST SELLER FOR ANY DEFECT IN THE GOODS SHALL BE VALID OR ENFORCEABLE UNLESS BUYER'S WRITTEN NOTICE THEREOF IS RECEIVED BY SELLER WITHIN ONE YEAR FROM THE DATE OF SHIPMENT.

Seller shall not be liable for any damage, injury or loss arising out of

the use of the goods if, prior to such damage, injury or loss, such goods are (1) damaged or misused following Seller's delivery to carrier; (2) not maintained, inspected, or used in compliance with applicable law and Seller's written instructions and recommendations; or (3) installed, repaired, altered or modified without compliance with such law, instructions or recommendations.

UNDER NO CIRCUMSTANCES SHALL SELLER BE LIABLE FOR INCIDENTAL OR CONSEQUENTIAL DAMAGES AS THOSE TERMS ARE DEFINED IN SECTION 2-715 OF THE UNIFORM COMMERCIAL CODE.

INDEMNIFICATION AND SAFE OPERATION

Buyer shall comply with and require its employees to comply with directions set forth in instructions and manuals furnished by Seller and shall use and require its employees to follow such instructions and manuals and to use reasonable care in the use and maintenance of the goods. Buyer shall not remove or permit anyone to remove any warning or instruction signs on the goods. In the event of personal injury or damage to property or business arising from the use of the goods, Buyer shall within 48 hours thereafter give Seller written notice of such injury or damage. Buyer shall cooperate with Seller in investigating any such injury or damage and in the defense of any claims arising therefrom.

If Buyer fails to comply with this section or if any injury or damage is caused, in whole or in part, by Buyer's failure to comply with applicable federal or state safety requirements, Buyer shall indemnify and hold Seller harmless against any claims, loss or expense for injury or damage arising from the use of the goods.

WARNING

Alterations or modifications of equipment and use of non-factory repair parts can lead to dangerous operation and injury.

TO AVOID INJURY:

- Do not alter or modify equipment
- Do not use equipment to lift, support or otherwise transport people
- Do not suspend unattended loads over people



Columbus McKinnon Corporation
140 John James Audubon Parkway
Amherst, New York 14228-1197
Phone 1-800-888-0985
Fax 716-689-5644