

# PARTS LIST AND INSTRUCTION MANUAL

# BUDGIT

STEEL FRAME  
LOW HEADROOM TROLLEY HOIST  
1-1/2 THRU 24 TON CAPACITIES  
PUSH AND HAND GEARED TYPES

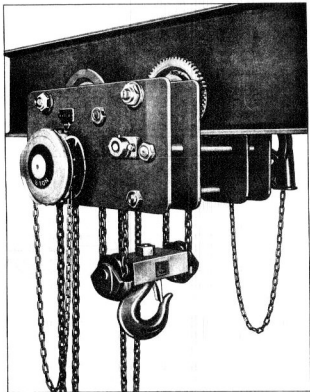

**BUDGIT**

LIFT-TECH INTERNATIONAL, USA  
414 WEST BROADWAY AVE. • P.O. BOX 769  
MUSKEGON, MICHIGAN 49443-9769

PHONE TOLL FREE 800-742-9269  
FAX 800-742-9270

## Table of Contents

Do's and Don'ts for Hoist Operation .....	3
Repair Parts Ordering Information .....	4
Installation .....	4
Inspection .....	5
Inspection Record .....	5
Record Copy .....	6
Hoist Maintenance	
Handwheel Side, Parts Service .....	7
Gear Cover Side, Parts Service .....	7
Reassembling .....	7
Trolley Wheel, Parts Service .....	7
Timing Marks .....	8
Lubrication .....	9
Chain Reeving .....	9
Mechanism - Handwheel End .....	10
Mechanism - Gear End .....	13
Hoist Assembly .....	14
Bottom Block Assembly .....	20
Trolley Assembly .....	22
Trolley Drive Assembly .....	23
Wheel Assembly .....	24
Track Clamp Assembly .....	26
Chain Specifications .....	27

**CAUTION: THIS EQUIPMENT ILLUSTRATED AND DESCRIBED IN THIS BULLETIN IS DESIGNED FOR MANUAL OPERATION ONLY AND IS NOT TO BE POWER DRIVEN, NOR IS IT SUITABLE FOR LISTING PEOPLE.**

**NOTE:** Before operating this hoist read ASME B30.16 Safety Standard for Overhead Hoists and this manual. Make this information available to all persons who will install, operate or maintain this equipment.

A Lockout/Tagout policy and procedure shall be implemented by the owner or user of all hoists.

# DO's AND DON'TS FOR HOIST OPERATION

## DO'S

1. EXAMINE hoist before each shift. CHECK for damaged hooks or chains, also make sure the hoist is properly secured. Make sure your hoist is clean and well lubricated.
2. CHECK daily the chain for improper seating, twisting, kinking, wear or other defects before operating the hoist. If these are not checked, the chain may break under a normal load.
3. BE SURE there are no objects in the way of a load or hook when moving the hoist on the beam.
4. MAKE SURE a load clears neighboring stock piles or machinery when raising or lowering the load.
5. CENTER hoist unit over the load before lifting.
6. AVOID swinging of load or load hook when traveling the hoist.
7. PROPERLY secure outdoor hoist when unattended.
8. KEEP load block above head level when not in use.
9. BE SURE the sling is properly seated in the saddle of the hook. Tip loading leads to hook spreading and possible failure. Hook latch should not support any part of the load.
10. DO READ ASME B30.16 Specification before operating hoist.
11. DO lift a load only a few inches then check load balance and brake operation before proceeding.

## DON'TS

1. NEVER lift load with hoist until all personnel are clear.
  2. DO NOT allow any unqualified personnel to operate hoist.
  3. AVOID collisions or bumping of hoists.
  4. DO not transport load over personnel.
  5. NEVER carry personnel on the hook or the load.
  6. DO NOT operate hoist if you are not physically fit to do so.
  7. NEVER pick up a load beyond the capacity appearing on the hoist.
  8. DO NOT tamper with any parts of the hoist unless you are a qualified maintenance person.
  9. NEVER use the hoist chain as a sling.
  10. DO NOT use chain as ground for welding. NEVER touch the welding electrode to the chain.
  11. DO NOT divert attention from load while operating hoist.
  12. DO NOT leave a load suspended in the air at the end of a work shift, or for extended periods of time and DO NOT leave a load unattended during regular working hours.
  13. DO NOT tip or "point" load a hook.
  14. DO NOT consider this list all inclusive.
  15. DO NOT operate a hoist in need of adjustment or repair.
  16. DO NOT operate a hand hoist with power or more than one operator.
  17. DO NOT operate a hoist that has been tagged out of service.
-

# REPAIR PARTS ORDERING INFORMATION

This instruction and parts manual is provided as a convenience to assist you in ordering repair parts for your Chester Zephyr Low Head Room Trolley Hoist.

Give all information listed below. This will enable the factory to promptly fill your order.

1. Provide complete identification data from hoist serial number or nameplate located on the trolley hoist side plate. In the event identification tags are missing, advise hoist capacity and complete beam size on which it operates.
2. Provide part numbers, description, and quantity required.
3. Provide correct shipping destination.

If it becomes necessary to return the complete hoist or certain parts to the factory, authorization is required. Provide a written explanation for return. All returns must be made by prepaid freight.

LIFT-TECH INTERNATIONAL, USA  
414 WEST BROADWAY AVE. • P.O. BOX 769  
MUSKEGON, MICHIGAN 49443-0769  
PHONE TOLL FREE 800-742-9269  
FAX 800-742-9270

---

## INSTALLATION

The hoisting unit is custom sized at the factory to fit on a specific beam size. Most units are slipped over the end of the supporting rail or beam; however, removable wheels\* are provided which enables the unit to be fitted on a beam with obstructed ends.

See parts breakdown page 7 for additional information regarding disassembly.

The distance between trolley wheel flanges (measured at the tread diameter) should be  $\frac{1}{16}$ " to  $\frac{3}{16}$ " greater than the beam flange width for proper running clearance. This clearance should be checked before operating the hoist under load. The hoist should be traversed the entire length of the beam to check for beam interference points, proper side clearance and effectiveness of the beam stops. If everything is satisfactory, the procedure should be repeated with a capacity load as a functional installation test.

**WARNING:** Before installing this trolley hoist, make certain that the trolley wheel contour is correct for the type of beam the unit will operate on and that the trolley wheel spacing is correct for the beam flange width. Flat flange beams should have flat tread or universal tread wheels and tapered flange beams should have tapered or universal tread wheels.

**WARNING:** Always make sure all end stops are securely in place before operating a hoist on a runway beam to prevent the hoist from falling from the open beam end.

See page 6 for chain container mounting instructions and warnings.

\*Feature not available on units operating on patented monorail tracks.

# INSPECTION

NOTE: READ ANSI B30.16 FOR ADDITIONAL INSPECTION REQUIREMENTS

Frequent Inspection — (Daily or before using.)

- (A) BRAKING MECHANISM - Check by lifting load a short distance then lowering to its original position while checking for slippage or free run.
- (B) LOAD CHAIN - For wear, twists, broken or otherwise damaged links. Chain should be clean and free of foreign material or excessive rust. Chain should be properly lubricated.
- (C) HOOK - For wear, heavy nicks, cracks or deformation. The hook must turn freely and the latch should be operative.

**Note:** Any hook that is twisted or has throat opening in excess of normal indicates overloading or abuse of the hoist and requires an inspection of all other load bearing components for damage.

Annual inspection — (More often if in heavy use or an adverse environment.)

- (A) Chain, load sheaves and other sheaves for excessive wear or chain stretch.
- (B) HOOK - Dye penetrant, magnetic particle or other suitable crack detecting inspection. The hook must turn freely and the latch should be operative.
- (C) HOOK RETAINING PINS OR WELDS should be inspected.
- (D) BRAKE MECHANISM - Worn, glazed or contaminated friction discs, worn pawls and damaged pawl springs.
- (E) LOAD BEARING PARTS - Worn, cracked or distorted parts such as hand chain wheels, chain attachments, suspension bolts, shafts, gears, and bearings.
- (F) CHAIN CONTAINER MOUNTING BOLTS AND BRACKETS. (See page 6.)

---

## INSPECTION RECORD

Written, dated and signed inspection report and records should be made on the hoist. A sample log form is furnished on page 6.

## MAINTENANCE AND OPERATING PROCEDURES: (USER'S RESPONSIBILITY)

All equipment should be inspected, tested, operated, and maintained according to the manufacturer's recommendations and the applicable sections of ASME/ANSI B30.16, B30.11, and B30.17. Consideration should also be given to pertinent federal, state and local regulations.

# RECORD COPY

## Inspection Log

Inspection No. \_\_\_\_\_ Date \_\_\_\_\_

Inspector \_\_\_\_\_

### Comments

- A. Chain and Sheaves \_\_\_\_\_
- B. Hook and Retainer \_\_\_\_\_
- C. Brake Mechanism \_\_\_\_\_
- D. Load Bearing Parts \_\_\_\_\_
- E. Other Parts \_\_\_\_\_

## CHAIN CONTAINER INSTALLATION NOTE

**THE CHAIN CONTAINER FOR THIS HOIST HAS BEEN SHIPPED LOOSE. FOLLOW THESE INSTRUCTIONS TO INSTALL THE CONTAINER AND TO LOAD THE CHAIN INTO THE CONTAINER.**

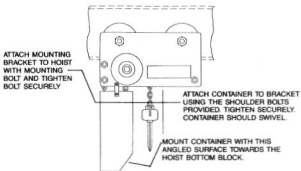

**CHAIN LOADING NOTE:** Lower load block as far as possible. After installing the chain container run the load block up allowing the hoist mechanism to fill the container. Verify the chain is loading properly into the container.

**WARNING!!** Never load chain into the container by hand!! Hand loading will cause the chain to tangle which will jam and damage the hoist.

**INSPECTION NOTE:** The mounting bolts for the container should be checked each time the hoist is inspected to insure they remain tight. The mounting holes on the container and brackets should be checked each time the hoist is inspected to insure they are not elongating and weakening the container or bracket.

# HOIST MAINTENANCE

**CAUTION:** Before disassembling any portion of the hoisting mechanism, the hook assembly must be lowered to the floor level for support, then continue to lower until stopped by the bolted end of the chain. This should prevent the free fall of the hook assembly or load chain when the load brake is disengaged.

## **Handwheel Side, Parts Service** (Includes load brake)

- (A) Unscrew 4 screws to remove handwheel cover. Pull cover and lift hand chain from handwheel, chain will remain looped through handwheel cover. If it is necessary to remove hand chain, find the unwelded link and bend open for removal.
- (B) Grasp handwheel and pull. After removal, the complete handwheel and brake assembly may be more conveniently placed in a soft jawed vise for disassembly.
- (C) Remove cotter pin and unscrew (counter clockwise) the handwheel from spindle. See Fig. 2 Page 8 for reassembly adjustment.
- (D) Lift off brake disc, ratchet, and second brake disc.
- (E) The pawl retaining ring and pawl spring nut should be removed to permit the pawl and pawl spring to be disassembled. The pawl stud can be removed by turning counter clockwise.
- (F) When reassembling, the smaller of the two brake discs is placed on the spindle last (against the handwheel assembly).

## **Gear Cover Side Parts Service**

- (A) Unscrew 4 screws on cover and remove cover.
- (B) Note the proper timing mark position of the two planet gears. See Figure 1 page 8.
- (C) Back-out the square head set screw to permit the pinion cage with the two planet gears to be pulled from the load shaft.
- (D) The two planet gears are removed by pulling the cotter pins and slipping the shafts from the gears.

**Reassembling:** Mount planet gears in pinion cage with cotter pins in place. Align set screw hole in pinion cage with the set screw hole in the drive shaft and time the planet gears as illustrated in Fig. 1 Page 8.

## **Trolley Wheel Parts Service**

- (A) To disassemble trolley wheels, back off axle nut, then force the axle toward center of hoist. The "C" washer should be free of its retaining cup shaped washer. When the "C" washer is removed, the axle can be withdrawn.

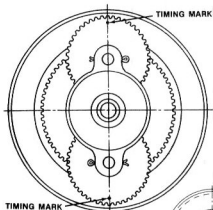

Fig. 1

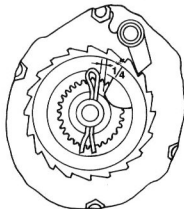

Fig. 2

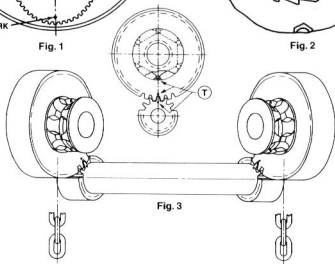

Fig. 3

**T** Indicates three timing marks in alignment

To enable the two independent chains to lift the bottom block evenly, the large gears and load sheaves must first be timed as illustrated. Then both gears must be timed simultaneously with the shaft pinions. This timing procedure is only necessary when the gears have been disengaged during disassembly, Fig. 3.

When replacing load chain, the two chains must be exactly the same length. The starting chain link on each chain must be simultaneously fed into the two lifting load sheaves. The starting links will pass over the top of the load sheave in a horizontal position to permit end attachment without twisting the chain. The second link of chain will be a standing link of chain; this link should have the weld furthest away from the center of the load sheave. Fig. 3.



# LUBRICATION

LUBRICANT	LOCATION	INSTRUCTIONS
NLGI No. 2 Grease	Fittings on chain sheave pins (roller bearing)  *Trolley wheels  Pawl Stud  Brake square thread	Annually or as required  After prolonged use or at reassembly  Coat lightly at reassembly  Coat lightly at reassembly
NLGI No. 2 with E.P. additive	Gears	After prolonged use or at reassembly
Intermediate oils preferably with E.P. additives	Chain	Immerse in container or swab with oil soaked rag. Wipe off excess oil. Should maintain chain rust free.
Bonded lubricants (similar to Dow Molykote M-88)	Chain	Use in place of oil, if oil residues are objectionable.

\*Not required on units equipped with sealed ball bearings. (Wheels will not have grease fittings.)

## CHAIN REEVING

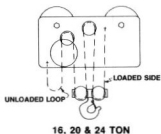
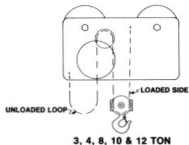
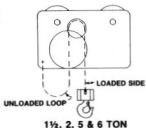

NOTE: LOOKING AT HANDWHEEL SIDE

## Mechanism - Handwheel End

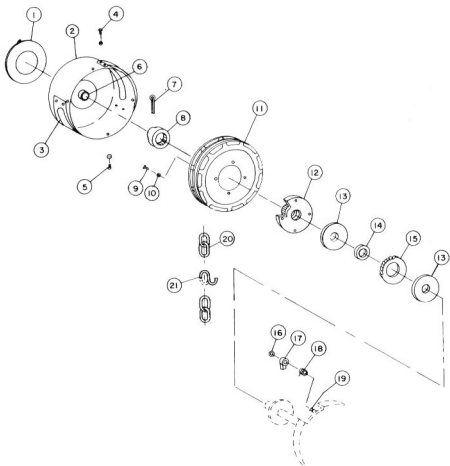

# Mechanism - Handwheel End

PART NO. PER CAPACITY

PC. NO.	DESCRIPTION	1½ TON	QTY.	2 TON	QTY.	3 TON	QTY.
1	Decal	C-947-C	1	C-947-C	1	C-947-C	1
2	Cover, Handwheel	C-968-A-005	1	C-968-A-005	1	C-968-A-005	1
3	Guide, Hand Chain	C-914-005	2	C-914-005	2	C-914-005	2
4	Screw, Hand Chain Guide	44-25-50	8	44-25-50	8	44-25-50	8
5	Screw, Handwheel Cover	999	4	999	4	999	4
6	Bushing, Handwheel Cover	C-903-005	1	C-903-005	1	C-903-005	1
7	Cotter Pin	135-31-1.75	1	135-31-1.75	1	135-31-1.75	1
8	Ring, Adjustable Check	C-925-005	1	C-925-005	1	C-925-005	1
9	Screw, Handwheel	14-25-50	4	14-25-50	4	14-25-50	4
10	Lockwasher, Handwheel	1-25	4	1-25	4	1-25	4
11	Handwheel	C-928-005	1	C-928-005	1	C-928-005	1
12	Insert, Threaded Handwheel	C-916-005	1	C-916-005	1	C-916-005	1
13	Disc, Brake	C-934L-005	2	C-934L-005	2	C-934L-005	2
14	Bushing, Bronze for 935	C-907-005	1	C-907-005	1	C-907-005	1
15	Ratchet	C-935-005	1	C-935-005	1	C-935-005	1
16	Ring, Pawl Snap	C-908-005	1	C-908-005	1	C-908-005	1
17	Pawl	C-923-005	1	C-923-005	1	C-923-005	1
18	Spring, Pawl	C-16256	1	C-16256	1	C-16256	1
19	Stud, Pawl	C-9301-015	1	C-9301-015	1	C-9301-015	1
20	Chain, Hand	C-937	1	C-937	1	C-937	1
21	Link, Connector	C-937L	1	C-937L	1	C-937L	1
PC. NO.	DESCRIPTION	4 TON	QTY.	5 TON	QTY.	6 TON	QTY.
1	Decal	C-947-C	1	C-947-C	1	C-947-C	1
2	Cover, Handwheel	C-968-A-005	1	C-968-015	1	C-968-015	1
3	Guide, Hand Chain	C-914-005	2	C-914-015	2	C-914-015	2
4	Screw, Hand Chain Guide	44-25-50	8	44-25-50	8	44-25-50	8
5	Screw, Handwheel Cover	999	4	999	4	999	4
6	Bushing, Handwheel Cover	C-903-005	1	C-903-015	1	C-903-015	1
7	Cotter Pin	135-31-1.75	1	135-31-1.75	1	135-31-1.75	1
8	Ring, Adjustable Check	C-925-005	1	C-925-005	1	C-925-005	1
9	Screw, Handwheel	14-25-50	4	14-25-50	4	14-25-50	4
10	Lockwasher, Handwheel	1-25	4	1-25	4	1-25	4
11	Handwheel	C-928-005	1	C-928-015	1	C-928-015	1
12	Insert, Threaded Handwheel	C-916-005	1	C-916-015	1	C-916-015	1
13	Disc, Brake	C-934L-005	2	C-934-015	2	C-934-015	2
14	Bushing, Bronze for 935	C-907-005	1	C-907-005	1	C-907-005	1
15	Ratchet	C-935-005	1	C-935-015	1	C-935-015	1
16	Ring, Pawl Snap	C-908-005	1	C-908-005	1	C-908-005	1
17	Pawl	C-923-005	1	C-923-005	1	C-923-005	1
18	Spring, Pawl	C-16256	1	C-16257	1	C-16257	1
19	Stud, Pawl	C-9301-015	1	C-9301-015	1	C-9301-015	1
20	Chain, Hand	C-937	1	C-937	1	C-937	1
21	Link, Connector	C-937L	1	C-937L	1	C-937L	1

# Mechanism - Handwheel End

PART NO. PER CAPACITY

PC. NO.	DESCRIPTION	8 TON	QTY.	10 TON	QTY.	12 TON	QTY.
1	Decal	C-947-C	1	C-947-C	1	C-947-C	1
2	Cover, Handwheel	C-968-015	1	C-968-015	1	C-968-015	1
3	Guide, Hand Chain	C-914-015	2	C-914-015	2	C-914-015	2
4	Screw, Hand Chain Guide	44-25-50	8	44-25-50	8	44-25-50	8
5	Screw, Handwheel Cover	999	4	999	4	999	4
6	Bushing, Handwheel Cover	C-903-015	1	C-903-015	1	C-903-015	1
7	Cotter Pin	135-31-1.75	1	135-31-1.75	1	135-31-1.75	1
8	Ring, Adjustable Check	C-925-005	1	C-925-005	1	C-925-005	1
9	Screw, Threaded Insert	14-25-50	4	14-25-50	4	14-25-50	4
10	Lockwasher, Threaded Insert	1-25	4	1-25	4	1-25	4
11	Handwheel	C-928-015	1	C-928-015	1	C-928-015	1
12	Insert, Threaded Handwheel	C-916-015	1	C-916-015	1	C-916-015	1
13	Disc, Brake	C-934-015	2	C-934-015	2	C-934-015	2
14	Bushing, Bronze for 935	C-907-005	1	C-907-005	1	C-907-005	1
15	Ratchet	C-935-015	1	C-935-015	1	C-935-015	1
16	Ring, Pawl Snap	C-908-005	1	C-908-005	1	C-908-005	1
17	Pawl	C-923-005	1	C-923-005	1	C-923-005	1
18	Spring, Pawl	C-16257	1	C-16257	1	C-16257	1
19	Stud, Pawl	C-9301-015	1	C-9301-015	1	C-9301-015	1
20	Chain, Hand	C-937		C-937		C-937	
21	Link, Connector	C-937L	1	C-937L	1	C-937L	1
PC. NO.	DESCRIPTION	16 TON	QTY.	20 TON	QTY.	24 TON	QTY.
1	Decal	C-947-C	1	C-947-C	1	C-947-C	1
2	Cover, Handwheel	C-968-015	1	C-968-015	1	C-968-015	1
3	Guide, Hand Chain	C-914-015	2	C-914-015	2	C-914-015	2
4	Screw, Hand Chain Guide	44-25-50	8	44-25-50	8	44-25-50	8
5	Screw, Handwheel Cover	999	4	999	4	999	4
6	Bushing, Handwheel Cover	C-903-015	1	C-903-015	1	C-903-015	1
7	Cotter Pin	135-31-1.75	1	135-31-1.75	1	135-31-1.75	1
8	Ring, Adjustable Check	C-925-005	1	C-925-005	1	C-925-005	1
9	Screw, Handwheel	14-25-50	4	14-25-50	4	14-25-50	4
10	Lockwasher, Handwheel	1-25	4	1-25	4	1-25	4
11	Handwheel	C-928-015	1	C-928-015	1	C-928-015	1
12	Insert, Threaded Handwheel	C-916-015	1	C-916-015	1	C-916-015	1
13	Disc, Brake	C-934-015	2	C-934-015	2	C-934-015	2
14	Bushing, Bronze for 935	C-907-005	1	C-907-005	1	C-907-005	1
15	Ratchet	C-935-015	1	C-935-015	1	C-935-015	1
16	Ring, Pawl Snap	C-908-005	1	C-908-005	1	C-908-005	1
17	Pawl	C-923-005	1	C-923-005	1	C-923-005	1
18	Spring, Pawl	C-16257	1	C-16257	1	C-16257	1
19	Stud, Pawl	C-9301-015	1	C-9301-015	1	C-9301-015	1
20	Chain, Hand	C-937		C-937		C-937	
21	Link, Connector	C-937L	1	C-937L	1	C-937L	1

## Mechanism - Gear End

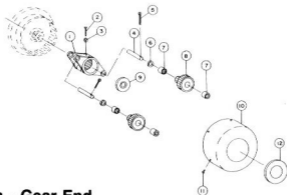

## Mechanism - Gear End

### PART NO. PER CAPACITY

PC. NO.	DESCRIPTION	1½ & 2 TON	QTY.	3 & 4 TON	QTY.	5 & 6 TON	QTY.
1	Cage, Pinion	C-921-01	1	C-921-01	1	C-921-015	1
2	Screw, Sq. Head	60-31-87	1	60-31-87	1	60-31-87	1
3	Nut, Lock	96-31-2	1	96-31-2	1	96-31-2	1
4	Shaft, Gear & Pinion	C-919-005	2	C-919-005	2	C-919-015	2
5	Cotter Pin	135-10-1.25	2	135-10-1.25	2	135-156-1.50	2
6	Washer, Thrust	NONE	0	NONE	0	6-64-1.12-.04	2
7	Bearing, Gear & Pinion	C-922-005	4	C-922-005	4	C-922-015	4
8	Gear & Pinion	C-927-01	2	C-927-01	2	C-927-02	2
9	Block, Cage Bearing	C-959-005	1	C-959-005	1	C-959-015	1
10	Cover, Gear	C-930-005	1	C-930-005	1	C-930-015	1
11	Screw, Cover	999	4	999	4	999	4
12	Decal	C-947-D	1	C-947-D	1	C-947-D	1

PC. NO.	DESCRIPTION	8 TON	QTY.	10 & 12 TON	QTY.	16 TON	QTY.	20 & 24 TON	QTY.
1	Cage, Pinion	C-921-015	1	C-921-015	1	C-921-015	1	C-921-015	1
2	Screw, Sq. Head	60-31-87	1	60-31-87	1	60-31-87	1	60-31-87	1
3	Nut, Lock	96-31-2	1	96-31-2	1	96-31-2	1	96-31-2	1
4	Shaft, Gear & Pinion	C-919-015	2	C-919-015	2	C-919-015	2	C-919-015	2
5	Cotter Pin	135-156-1.50	2	135-156-1.50	2	135-156-1.50	2	135-156-1.50	2
6	Washer, Thrust	6-64-1.12-.04	2	6-64-1.12-.04	2	6-64-1.12-.04	2	6-64-1.12-.04	2
7	Bearing, Gear & Pinion	C-922-015	4	C-922-015	4	C-922-015	4	C-922-015	4
8	Gear & Pinion	C-927-02	2	C-927-02	2	C-927-02	2	C-927-02	2
9	Block, Cage Bearing	C-959-015	1	C-959-015	1	C-959-015	1	C-959-015	1
10	Cover, Gear	C-930-015	1	C-930-015	1	C-930-015	1	C-930-015	1
11	Screw, Cover	999	4	999	4	999	4	999	4
12	Decal	C-947-D	1	C-947-D	1	C-947-D	1	C-947-D	1

# Hoist Assembly

1½, 2, 5 & 6 Ton

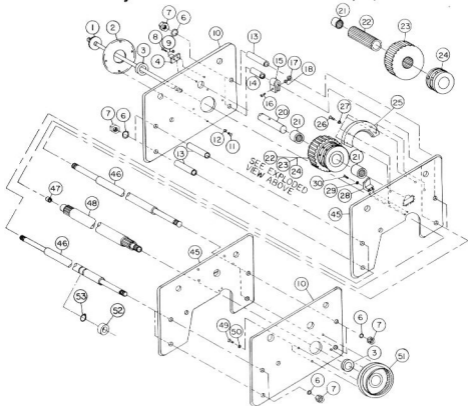

PART NO. PER CAPACITY

PC. NO.	DESCRIPTION	1½ TON	QTY.	2 TON	QTY.	5 TON	QTY.	6 TON	QTY.
1	Spindle Assembly	C-9318-005	1	C-9318-005	1	C-9318-015	1	C-9318-015	1
2	Frame Half, Handwheel Side	C-9262-005	1	C-9262-005	1	C-9262-015	1	C-9262-015	1
3	Bearing, Drive Shaft	C-960-005	2	C-960-005	2	C-960-015	2	C-960-015	2
4	Keeper, Load Shaft	C-9362-015	4	C-9362-015	4	C-9362-015	4	C-9362-015	4
5	Keeper, Idler Shaft	NONE		NONE		NONE		NONE	
6	Lockwasher, Separator Stud	1-75	8	1-75	8	1-100	8	1-100	8
7	Nut, Hex, Separator Stud	96-75-2	8	96-75-2	8	96-100-2	8	96-100-2	8
8	Bolt, Keeper	31-31-62	8	31-31-62	8	31-37-75	8	31-37-75	8
9	Lockwasher, Keeper	1-31	8	1-31	8	1-37	8	1-37	8
10	Side Plate, Outboard	C-9300A-015	2	C-9300A-015	2	C-9300A-05	2	C-9300A-05	2

# Hoist Assembly

# 1½, 2, 5 & 6 Ton

## PART NO. PER CAPACITY

PC. NO.	DESCRIPTION	1½ TON	QTY.	2 TON	QTY.	5 TON	QTY.	6 TON	QTY.
11	Bolt, Frame Half Hdwh'l Side	31-37-75	4	31-37-75	4	31-43-1.00	4	31-43-1.00	4
12	Lockwasher, Frame Half	1-37	4	1-37	4	1-43	4	1-43	4
13	Pipe Spacer, Long	C-9307-P1	8	C-9307-P1	8	C-9307-P5	8	C-9307-P5	8
14	Pipe Spacer, Short	C-9307-P2	2	C-9307-P2	2	C-9307-P6	2	C-9307-P6	6
15	Bale, Dead End	C-9393-015	2	C-9393-015	2	C-9393-05	2	C-9393-05	2
16	Bolt, Dead End	22-31-1.50	2	22-31-1.50	2	18-62-2.75	2	18-62-2.75	2
17	Nut, Hex, Bale	70-31-2	2	70-31-2	2	70-62-2	2	70-62-2	2
18	Lockwasher, Bale	1-31	2	1-31	2	1-62	2	1-62	2
20	Axle, Bull Gear	C-9338-015	2	C-9338-015	2	C-9338-05	2	C-9338-05	2
21	Bearing	TC-12E16-012	4	TC-12E16-012	4	GM-2226-020	4	GM-2226-020	4
22	Shaft, Bull Gear Splined	C-9374-015	2	C-9374-015	2	C-35469	2	C-35469	2
23	Gear, Bull	C-9390-015	2	C-9390-015	2	C-9390-05	2	C-9390-05	2
24	Load Wheel	C-929-005	2	C-929-005	2	C-9329-05	2	C-9329-05	2
25	Guide, Load Chan	C-9305-015	2	C-9305-015	2	C-9305-05	2	C-9305-05	2
26	Bolt, Guide	31-31-75	8	31-31-75	8	31-37-1.00	8	31-37-1.00	8
27	Lockwasher, Guide	1-31	8	1-31	8	1-37	8	1-37	8
28	Stripper	C-9324-015	2	C-9324-015	2	C-9324-05	2	C-9324-05	2
29	Lockwasher, Stripper	1-25	4	1-25	4	1-31	4	1-31	4
30	Bolt Stripper	31-25-87	4	31-25-87	4	31-31-1.25	4	31-31-1.25	4
45	Plate, Inboard	C-9300B-015	2	C-9300B-015	2	C-9300B-05	2	C-9300B-05	2
46	Stud, Separator	C-9312-015	4	C-9312-015	4	C-9312-05	4	C-9312-05	4
47	Bushing, Drive Shaft	NONE	0	NONE	0	C-911-015	1	C-911-015	1
48	Shaft, Drive	C-9384-015	1	C-9384-015	1	C-9384-05	1	C-9384-05	1
49	Bolt, Frame Half Geared	31-37-1.00	4	31-37-1.00	4	31-43-1.25	4	31-43-1.25	4
50	Lockwasher Frame, Half Geared End	1-37	4	1-37	4	1-43	4	1-43	4
51	Frame Half, Geared End	C-9261-005	1	C-9261-005	1	C-9261-015	1	C-9261-015	1
52	Underbeam Roller	C-31421	4	C-31421	4	C-31430	4	C-31430	4
53	Roller Snap Ring	5100-100	8	5100-100	8	5100-125	8	5100-125	8

# Hoist Assembly

3, 4, 8, 10 & 12 Ton

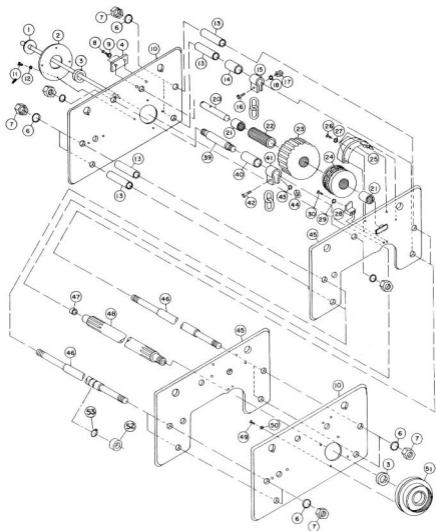



**Hoist Assembly****PART NO. PER CAPACITY****3, 4, 8, 10 & 12 Ton**

<b>PC. NO.</b>	<b>DESCRIPTION</b>	<b>3 &amp; 4 TON</b>	<b>QTY.</b>	<b>8 TON</b>	<b>QTY.</b>	<b>10 &amp; 12 TON</b>	<b>QTY.</b>
1	Spindle Assembly	C-9318-005	1	C-9318-015	1	C-9318-015	1
2	Frame Half, Handwheel Side	C-9262-005	1	C-9262-015	1	C-9262-015	1
3	Bearing, Drive Shaft	C-960-005	2	C-960-015	2	C-960-015	2
4	Keeper, Load Shaft	C-9362-015	2	C-9362-05	2	C-9362-05	2
5	Keeper, Idler Shaft	NONE		NONE		NONE	
6	Lockwasher, Separator Stud	1-87	8	1-125	8	1-125	8
7	Nut, Hex, Separator Stud	96-87-2	8	96-125-2	8	96-125-2	8
8	Bolt, Keeper	31-31-62	4	31-37-75	4	31-37-75	4
9	Lockwasher, Keeper	1-31	4	1-37	4	1-37	4
10	Side Plate, Outboard	C-9300A-03	2	C-9300A-08	2	C-9300A-10	2
11	Bolt, Frame Half Handwheel	31-37-75	4	31-43-10	4	31-43-10	4
12	Lockwasher, Frame Half	1-37	4	1-43	4	1-43	4
13	Spacer Pipe, Long	C-9307-P3	8	C-9307-P7	8	C-9307-P7	8
14	Spacer Pipe, Short	C-9307-P2	2	C-9307-P10	2	C-9307-P10	2
15	Bale, Dead End	C-9393-03	2	C-9393-08	2	C-9393-10	2
16	Bolt, Dead End	22-31-150	2	22-43-250	2	18-62-275	2
17	Nut, Hex, Bale	70-31-2	2	70-43-2	2	70-62-2	2
18	Lockwasher, Bale	1-31	2	1-43	2	1-62	2
20	Axle, Bull Gear	C-9338-015	2	C-9338-08	2	C-9338-05	2
21	Bearing	TC-12E16-012	4	GM-2024-020	4	GM-2226-020	4
22	Shaft, Bull Gear Splined	C-9374-015	1	C-9374-08	1	C-35469	1
23	Bull Gear	C-9390-015	2	C-9390-08	2	C-9390-05	2
24	Load Wheel	C-929-005	2	C-9329-08	2	C-9329-05	2
25	Guide, Load Chain	C-9305-015	2	C-9305-08	2	C-9605-10	2
26	Bolt, Guide	31-37-100	8	31-37-100	8	31-37-100	8
27	Lockwasher, Guide	1-37	8	1-37	8	1-37	8
28	Stripper	C-9324-015	2	C-9324-05	2	C-9324-05	2
29	Lockwasher, Stripper	1-25	4	1-31	4	1-31	4
30	Bolt, Stripper	31-25-87	4	31-31-125	4	31-31-125	4
39	Stud, Live End	C-9389-03	2	C-9389-08	2	C-9389-10	2
40	Spacer, Live End	C-9307-P2	2	C-9307-P9	2	C-9307-P9	2
41	Bale, Live End	C-9394-03	2	C-9394-08	2	C-9394-10	2
42	Bolt, Live End	31-31-137	2	31-43-250	2	31-62-325	2
43	Lockwasher, Live End	1-31	2	1-43	2	1-62	2
44	Nut, Live End	70-31-2	2	70-43-2	2	70-62-2	2
45	Plate, Inboard	C-9300B-03	2	C-9300B-08	2	C-9300B-10	2
46	Stud, Separator	C-9312-03	4	C-9312-08	4	C-9312-10	4
47	Bushing, Drive Shaft	NONE	0	C-911-015	1	C-911-05	1
48	Shaft, Drive	C-9384-015	1	C-9384-05	1	C-9384-05	1
49	Bolt, Frame Half, Geared	31-37-100	4	31-43-125	4	31-43-125	4
50	Lockwasher, Frame Half	1-37	4	1-43	4	1-43	4
51	Frame Half, Geared End	C-9261-005	1	C-9261-015	1	C-9261-015	1
52	Underbeam Roller	C-31434	4	C-31442	4	C-31453	4
53	Roller Snap Ring	5100-112	8	5100-175	8	5100-175	8

# Hoist Assembly

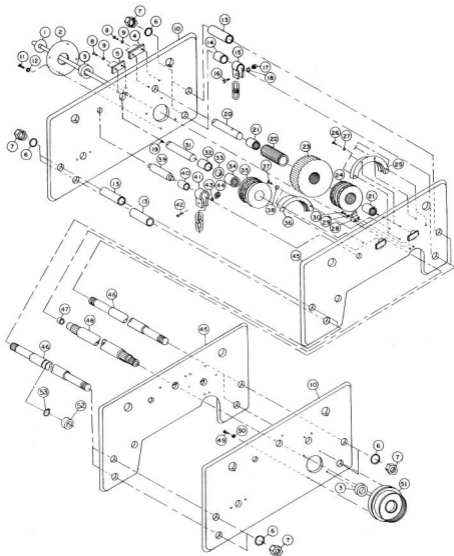

**Hoist Assembly**

PART NO. PER CAPACITY

**16, 20 & 24 Ton**

PC. NO.	DESCRIPTION	16 TON	QTY.	20 & 24 TON	QTY.
1	Spindle Assembly	C-9318-015	1	C-9318-015	1
2	Frame Half, Handwheel Side	C-9262-015	1	C-9262-015	1
3	Bearing, Drive Shaft	C-960-015	2	C-960-015	2
4	Keeper, Bull Gear Axle	C-9362-16	4	C-9362-16	4
5	Keeper, Idler Shaft	C-9362-16	4	C-9362-16	4
6	Lockwasher, Separator Stud	NONE		NONE	
7	Nut, Hex Separator Stud	96-1.75-2	8	96-2.00-2	8
8	Bolt, Keeper	31-37.75	8	31-37.75	8
9	Lockwasher, Keeper	1-37	8	1-37	8
10	Side Plate, Outboard	C-9300A-16	2	C-9300A-20	2
11	Bolt, Frame Half Handwheel	31-43.75	4	31-43-1.00	4
12	Lockwasher, Frame Half	1-43	4	1-43	4
13	Spacer, Pipe Long	C-9307-P12	8	C-9307-P12	8
14	Spacer, Pipe Short	C-9307-P15	2	C-9307-P15	2
15	Bale, Dead End	C-9393-16	2	C-9393-20	2
16	Bolt, Dead End	22-43-2.25	2	18-62-2.75	2
17	Nut, Hex Bale	70-43-2	2	70-62-2	2
18	Lockwasher, Bale	1-43	2	1-62	2
20	Axle Bull Gear	C-34229	2	C-9338-20	2
21	Bearing	GM-2024-020	4	GM-2226-020	4
22	Shaft, Bull Gear Splined	C-9374-08	1	C-35469	1
23	Gear, Bull	C-9390-08	2	C-9390-20	2
24	Load Wheel	C-9329-08	2	C-9329-05	2
25	Guide, Load Chain	C-9605-08	2	C-9605-10	2
26	Bolt, Guide	31-37-1.00	8	31-37-1.00	8
27	Lockwasher, Guide	1-37	8	1-37	8
28	Stripper	C-9324-05	2	C-9324-05	2
29	Lockwasher, Stripper	1-31	4	1-31	4
30	Bolt Stripper	31-31-1.50	4	31-31-1.50	4
31	Shaft, Top Idler	C-9391-16	2	C-9391-20	2
32	Spacer, Top Idler	C-9307-P14	2	C-9307-P16	2
33	Washer, Top Idler	6-187-3.25-12	2	6-187-3.25-12	2
34	Bearing, Idler Top	GM-2630-028	4	GM-3034-032	4
35	Sheave, Top Idler	C-35468	2	C-35467	2
36	Chain Guide, Idler	C-9634-16	1	C-9634-20	1
37	Bolt, Idler Guide	31-37-1.00	2	31-37-1.00	2
38	Lockwasher, Guide Idler	1-37	2	1-37	2
39	Stud, Live End	C-9389-16	2	C-9389-20	2
40	Spacer, Bale	C-9307-P13	2	C-9307-P13	2
41	Bale, Live End	C-9394-16	2	C-9394-20	2
42	Bolt, Live End Bale	18-50-2.50	2	31-37-3.25	2

# Hoist Assembly

# 16, 20 & 24 Ton

## PART NO. PER CAPACITY

PC. NO.	DESCRIPTION	16 TON	QTY.	20 & 24 TON	QTY.
43	Lockwasher, Bale	1-50	2	1-37	2
44	Nut, Bale	70-50-2	2	70-37-2	2
45	Plate, Inboard	C-9300B-16	2	C-9300B-20	2
46	Stud, Separator	C-9312-16	4	C-9312-20	4
47	Bushing, Drive Shaft	C-911-015	1	C-911-015	1
48	Shaft, Drive	C-9384-05	1	C-9384-05	1
49	Bolt, Frame Half Geared	31-43-1.50	4	31-43-1.75	4
50	Lockwasher, Frame Half Geared	1-43	4	1-43	4
51	Frame Half, Geared End	C-9261-015	1	C-9261-20	1
52	Underbeam Roller	C-31454	4	C-31457	4
53	Roller Snap Ring	5100-225	8	5100-250	8

# Bottom Block Assembly

# 1½, 2, 5 & 6 Ton

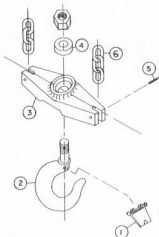

## PART NO. PER CAPACITY

PC. NO.	DESCRIPTION	1½ TON	QTY.	2 TON	QTY.	5 TON	QTY.	6 TON	QTY.
1	Latch Assembly	HL-10-90063	1	HL-10-90063	1	HL-10-90107	1	HL-10-90107	1
2	Bottom Hook & Nut	C-9640-015	1	C-9640-015	1	C-9340-05	1	C-9340-06	1
3	Bottom Crosshead	C-9352-015	1	C-9352-015	1	C-9352-05	1	C-9352-05	1
4	Thrust Bearing	C-939-015	1	C-939-015	1	C-939-05	1	C-939-05	1
5	Drive Pin	131-31-1.75	2	131-31-1.75	2	131-43-2	2	131-43-2	2
6	Load Chain	C-938A-005	2 pc	C-938A-005	2 pc	C-38A-03	2 pc	C-38A-03	2 pc

# Bottom Block Assembly

3, 4, 8, 10 & 12 Ton

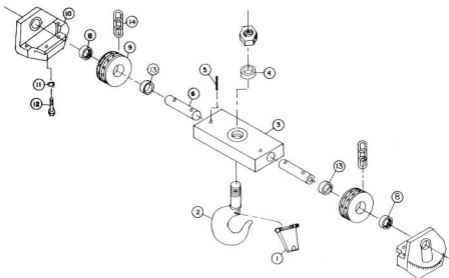

## PART NO. PER CAPACITY

PC. NO.	DESCRIPTION	3 TON	QTY.	4 TON	QTY.	8 TON	QTY.	10 TON	QTY.	12 TON	QTY.
1	Latch Assembly	HL-10-90081	1	HL-10-90107	1	HL-10-90125	1	HL-10-90125	1	HL-10-90125	1
2	Bottom Hook & Nut	C-9340-03	1	C-9340-04	1	C-9340-08	1	C-9340-10	1	C-9340-10	1
3	Bottom Crosshead	C-9352-03	1	C-9352-03	1	C-9352-08	1	C-9352-10	1	C-9352-10	1
4	Thrust Bearing	C-939-03	1	C-939-04	1	C-939-08	1	C-939-10	1	C-939-10	1
5	Drive Pin	NONE		NONE		127.37-3.0	2	127.37-3.0	2	127.37-3.0	2
6	Axle, Bottom Block Idler	NONE		NONE		C-9354-08	2	C-9354-10	2	C-9354-10	2
8	Bearing Idler	GM-2226-020	2	GM-2226-020	2	GM-2630-028	4	GM-3034-032	4	GM-3034-032	4
9	Sheave, Bottom Block Idler	C-9356-03	2	C-9356-03	2	C-35468	2	C-35467	2	C-35467	2
10	Guard, Bottom Idler	C-9388-03	2	C-9388-03	2	C-9688-08	2	C-9688-10	2	C-9688-10	2
11	Lockwasher, Guard	1-50	4	1-50	4	1-62	4	1-62	4	1-62	4
12	Bolt, Guard	18-50-1.75	4	18-50-1.75	4	18-62-1.75	4	18-62-1.75	4	18-62-1.75	4
13	Bearing Inner Race	IR-1816	2	IR-1816	2	NONE		NONE		NONE	
14	Load Chain	C-38A-005	2 pc	C-38A-005	2 pc	C-938-02	2 pc	C-38A-03	2 pc	C-38A-03	2 pc

## Bottom Block Assembly

16, 20 & 24 Ton

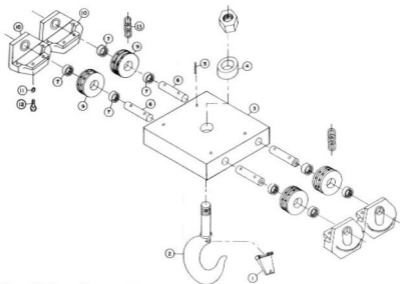

## Trolley Drive Assembly

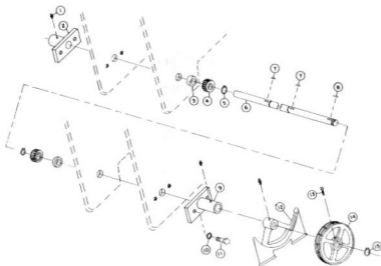

**Bottom Block Assembly****16, 20 & 24 Ton****PART NO. PER CAPACITY**

PC. NO.	DESCRIPTION	16 TON	QTY.	20 TON	QTY.	24 TON	QTY.
1	Latch Assembly	HL-10-90143	1	HL-10-90161	1	HL-10-90161	1
2	Bottom Hook & Nut	C-9340-16	1	C-9340-20	1	C-9340-20	1
3	Bottom Crosshead	C-9352-16	1	C-9352-20	1	C-9352-20	1
4	Thrust Bearing	C-939-16	1	C-939-25	1	C-939-25	1
5	Drive Pin	127-37-3.0	4	127-37-3.0	4	127-37-3.0	4
6	Axle, Bottom Block Idler	C-9354-08	4	C-9354-10	4	C-9354-10	4
7	Bearing, Idler	GM-2630-028	8	GM-3034-032	8	GM-3034-032	8
9	Sheave, Bottom Block Idler	C-35468	4	C-35467	4	C-35467	4
10	Guard, Idler Bottom	C-9688-08	4	C-9688-10	4	C-9688-10	4
11	Lockwasher, Guard	1-62	4	1-62	4	1-62	4
12	Bolt, Guard	18-62-1.75	8	18-62-1.75	8	18-62-1.75	8
13	Load Chain	C-938-02	2 pc	C-38A-3	2 pc	C-38A-3	2 pc

**Trolley Drive Assembly****1½, 2, 3, 4, 5, 6, & 8 Ton****PART NO. PER CAPACITY**

PC. NO.	DESCRIPTION	1½ & 2 TON	QTY.	3 & 4 TON	QTY.	5 & 6 TON	QTY.	8 TON	QTY.
1	Lube Fitting	1743-B	3	1743-B	3	1743-B	3	1743-B	3
2	Block, Bearing Short	C-906-B	1	C-906-B	1	C-9106S-015	1	C-9106S-015	1
3	Spacer, Pinion	C-9395-015	2	C-9395-03	2	C-9395-05	2	C-9395-08	2
4	Gear, Pinion	C-14-T	2	C-16-T	2	C-16-T	2	C-16-T	2
5	Snap Ring, Pinion	5100-87	2	5100-87	2	5100-87	2	5100-87	2
6	Shaft, Trolley Drive	C-9611-015	1	C-9611-015	1	C-9611-05	1	C-9611-08	1
7	Key, Pinion Gear	13-25-25-50	2	13-25-25-50	2	13-25-25-50	2	13-25-25-50	2
8	Key, Handwheel	13-25-25-150	1	13-25-25-150	1	13-25-25-150	1	13-25-25-20	1
9	Block, Bearing Long	C-906-A	1	C-906-A	1	C-9106-015	1	C-9106S-015	1
10	Lockwasher, Brg Block	1-31	4	1-31	4	1-50	4	1-50	4
11	Bolt, Bearing Block	14-31-1.00	4	14-31-1.00	4	14-50-1.25	4	14-50-1.50	4
12	Guard, Swinging	C-9121-0075	1	C-9121-0075	1	C-9121-015	1	C-9121-015	1
13	Set, Screw, Sq. Head	58-25-87	1	58-25-87	1	58-25-87	1	58-37-1.25	1
14	Handwheel	C-9120-0075	1	C-9120-0075	1	C-9120-015	1	C-9120-015	1
15	Snap Ring, Handwheel	5100-87	1	5100-87	1	5100-87	1	5100-87	1

# Trolley Drive Assembly

# 10, 12, 16, 20 & 24 Ton

PART NO. PER CAPACITY

PC. NO.	DESCRIPTION	10 & 12 TON	QTY.	16 TON	QTY.	20 & 24 TON	QTY.
1	Lube Fitting	1743-B	3	1743-B	3	1728-B	3
2	Block, Bearing Short	C-9106S-10	1	C-9106S-16	1	C-9106S-10	1
3	Spacer, Pinion	C-9395-10	2	C-9395-16	2	C-9395-20	2
4	Gear, Pinion	C-16-T	2	C-20-T	2	C-20-T	2
5	Snap Ring, Pinion	5100-125	2	5100-125	2	5100-137	2
6	Shaft, Trolley Drive	C-9611-10	1	C-9611-16	1	C-9611-20	1
7	Key, Pinion Gear	13-25-25-50	2	13-31-31-50	2	13-31-31-50	2
8	Key, Handwheel	13-31-31-1.50	1	13-31-31-1.50	1	13-31-31-1.50	1
9	Block, Bearing Long	C-9106-10	1	C-9106-10	1	C-9106-20	1
10	Lockwasher, Brg. Block	1-50	4	1-50	4	1-50	4
11	Bolt, Bearing Block	14-50-1.50	4	14-50-1.50	4	14-50-1.50	4
12	Guard, Swinging	C-9121-10	1	C-9121-10	1	C-9121-25	1
13	Set Screw, Sq. Head	58-37-1.25	1	58-37-1.25	1	58-37-1.25	1
14	Handwheel	C-9120-10	1	C-9120-10	1	C-9120-25	1
15	Snap, Ring, Handwheel	5100-125	1	5100-125	1	5100-137	1

## Wheel Assembly

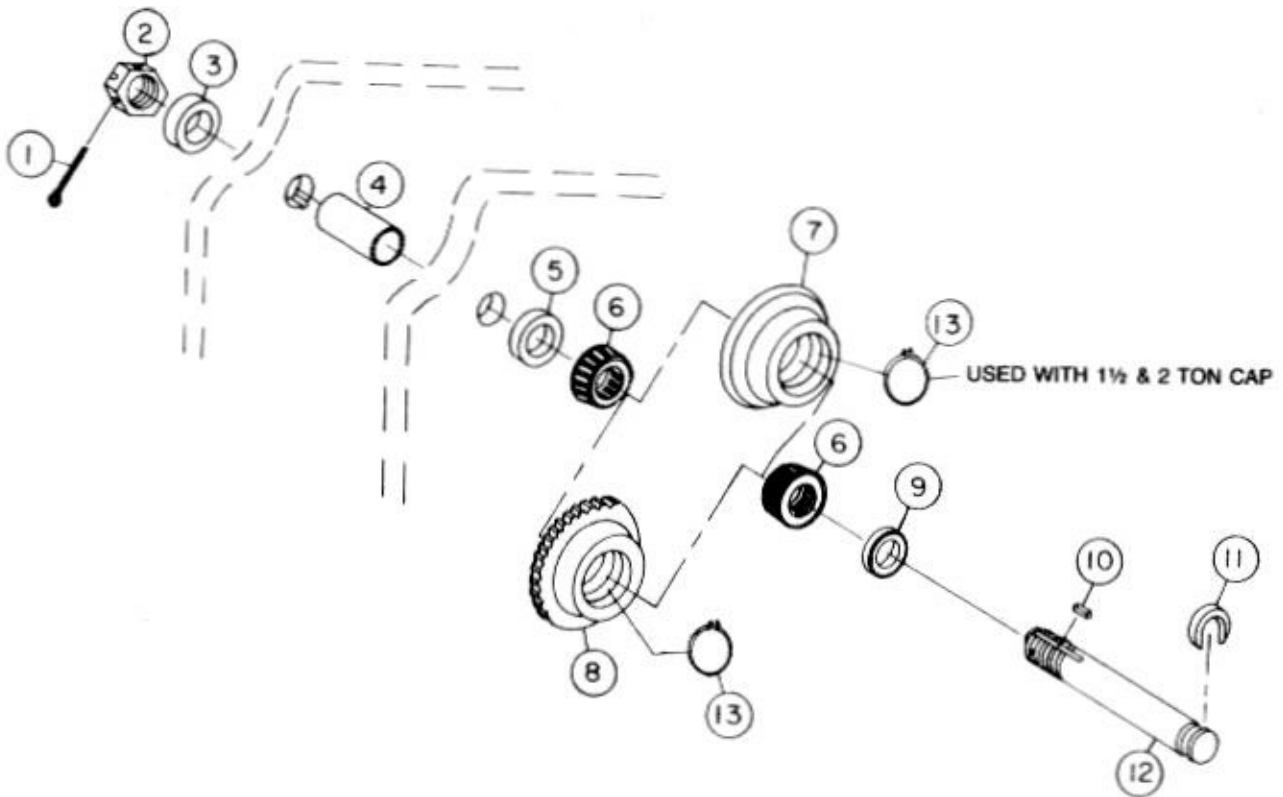



# Wheel Assembly

## 1½, 2, 3, 4, 5 & 6 Ton

### PART NO. PER CAPACITY

PC. NO.	DESCRIPTION	1½ & 2 TON	QTY.	3 & 4 TON	QTY.	5 & 6 TON	QTY.
1	Cotter Pin	NONE		NONE		NONE	
2	Nut, Axle	96-75-2		C-93112-05	1	C-93112-05	1
3	Spacer, Outboard	C-9315-015	1	C-9315-03	1	C-9315-05	1
4	Spacer, Plate	C-9307-P1	1	C-9307-P4	1	C-9307-P7	1
5	Spacer, Inboard	C-9314-015	1	C-9314-03	1	C-9314-05	1
6	Bearing	C-9107-015	2	C-9116-03	2	C-9116-03	2
7	Wheel, Plain W/Bearing Cup	C-9109-015	1	C-9109-03	1	C-9109-05	1
8	Wheel, Geared W/Brg. Cup	C-9108-015	1	C-9108-03	1	C-9108-05	1
9	Washer, Axle Cup	C-9309-015	1	C-9309-05	1	C-9309-05	1
10	Key, Axle	13-18-18-31	1	13-25-25-31	1	13-25-25-37	1
11	Washer, Axle "C"	C-9308-015	1	C-9308-03	1	C-9308-03	1
12	Axle	C-9310-015	1	C-9310-03	1	C-9310-05	1
13	Ring, Snap	5000-175	1	NONE		NONE	

# Wheel Assembly

## 8, 10, 12, 16, 20 & 24 Ton

### PART NO. PER CAPACITY

PC. NO.	DESCRIPTION	8 TON	QTY.	10 & 12 TON	QTY.	16 TON	QTY.	20 & 24 TON	QTY.
1	Cotter Pin	NONE		NONE		135-37-4.0	1	135-37-4.0	1
2	Nut, Axle	C-93112-08	1	C-93112-10	1	C-93112-10	1	C-93112-10	1
3	Spacer, Outboard	C-9315-08	1	C-9315-10	1	C-9315-16	1	C-9315-20	1
4	Spacer, Plate	C-9307-P8	1	C-9307-P11	1	C-9307-P11	1	C-9307-P11	1
5	Spacer, Inboard	C-9314-08	1	C-9314-10	1	C-9314-16	1	C-9314-20	1
6	Bearing	C-9116-08	2	C-9116-10	2	C-9116-10	2	C-9116-10	2
7	Wheel, Plain W/Brg. Cup	C-9109-08	1	C-9109-10	1	C-9109-16	1	C-9109-16	1
8	Wheel, Geared W/Brg. Cup	C-9108-08	1	C-9108-10	1	C-9108-16	1	C-9108-16	1
9	Washer, Axle Cup	C-9309-08	1	C-9309-10	1	C-9309-16	1	C-9309-16	1
10	Key, Axle	13-31-31-50	1	13-31-31-50	1	13-37-37-75	1	13-37-37-75	1
11	Washer, Axle "C"	C-9308-08	1	C-9308-10	1	C-9308-16	1	C-9308-16	1
12	Axle	C-9310-08	1	C-9310-10	1	C-9310-16	1	C-9310-20	1
13	Ring, Snap	NONE		NONE		NONE		NONE	

## Track Clamp Assembly

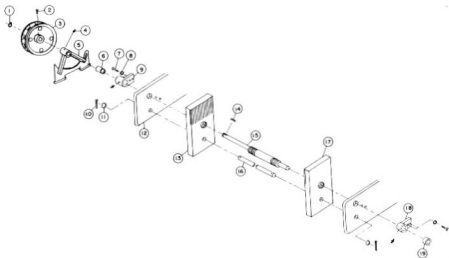

## Track Clamp Assembly

1½, 2, 3, 4, 5 & 6 TON

### PART NO. PER CAPACITY

PC. NO.	DESCRIPTION	1½ & 2 TON	QTY.	3 & 4 TON	QTY.	5 & 6 TON	QTY.
1	Snap Ring, Handwheel	5100-87	1	5100-87	1	5100-87	1
2	Set Screw, Square Head	58-25-87	1	58-25-87	1	58-25-87	1
3	Handwheel	C-9120-0075	1	C-9120-0075	1	C-9120-01	1
4	Lube Fitting	1743-B	3	1743-B	3	1743-B	3
5	Guard, Swinging	C-9121-0075	1	C-9121-0075	1	C-9121-01	1
6	Bushing, Bearing Block	NONE		NONE		NONE	
7	Bolt, Bearing Block	14-31-100	4	14-31-100	4	14-31-100	4
8	Lockwasher, Bearing Block	1-31	4	1-31	4	1-31	4
9	Block, Bearing	C-906B	1	C-906B	1	C-906B	1
10	Cotter Pin	135-18-1.0	2	135-18-1.0	2	135-18-1.0	2
11	Washer Guide Pin	2-625	2	2-625	2	2-750	2
12	Side Plate	LHTC-153-B-015	2	LHTC-153-B-015	2	LHC-153-B-05	2
13	Jaw, Left Hand	LHTC-150-L-015	1	LHTC-150-L-03	1	LHTC-150-L-05	1
14	Key, Handwheel	13-25-25-1.50	1	13-25-25-1.50	1	13-25-25-1.50	1
15	Screw, Track Clamp	LHTC-151-015	1	LHC-151-03	1	LHTC-151-05	1
16	Pin Guide	LHTC-152-015	1	LHTC-152-03	1	LHTC-152-05	1
17	Jaw, Right Hand	LHTC-150-R-015	1	LHTC-150-R-03	1	LHTC-150-R-05	1
18	Block, Bearing	C-906-B	1	C-906-B	1	C-906-B	1
19	Bushing, Brg. Block Short	NONE		NONE		NONE	

## Track Clamp Assembly

8, 10, 12, 16, 20 &amp; 24 Ton

## PART NO. PER CAPACITY

PC NO.	DESCRIPTION	8 TON	QTY.	10 & 12 TON	QTY.	16 TON	QTY.	20 & 24 TON	QTY.
1	Snap Ring, Handwheel	5100-87	1	5100-87	1	5100-87	1	5100-87	1
2	Set Screw, Square Head	58-25-87	1	58-25-87	1	58-25-87	1	58-25-87	1
3	Handwheel	C-9120-01	1	C-9120-01	1	C-9120-01	1	C-9120-01	1
4	Lube Fitting	1743-B	1	1743-B	1	1743-B	1	1743-B	1
5	Guard, Swinging	C-9121-01	1	C-9121-01	1	C-9121-01	1	C-9121-01	1
6	Bushing, Bearing Block	P-100-16	2	P-87-8	2	P-125-8	2	P-100-8	2
7	Bolt, Bearing Block	14-50-1.25	4	14-62-1.5	4	NONE	4	14-62-1.25	4
8	Lockwasher, Bearing Block	1-50	4	1-62	4	NONE	4	1-62	4
9	Block, Bearing Long	LHTC-153-WA-08	1	LHTC-153-WA-10	1	NONE	1	LHTC-153-WA-24	1
10	Cotter Pin	NONE		NONE		135-25-2.0	2	NONE	2
11	Washer, Guide Pin	NONE		NONE		2-1.0	2	NONE	2
12	Side Plate	LHTC-153-B-08	2	LHTC-153-B-10	2	LHTC-153-16	2	LHTC-153-24	2
13	Jaw, Left Hand	LHTC-150L-08	1	LHTC-150L-10	1	LHTC-150L-16	1	LHTC-150L-24	1
14	Key, Handwheel	13-25-25-150	1	13-25-25-150	1	13-25-25-150	1	13-25-25-150	1
15	Screw, Track Clamp	LHTC-151-08	1	LHTC-151-10	1	LHTC-151-16	1	LHTC-151-24	1
16	Pin, Guide	LHTC-152-08	1	LHTC-152-10	1	LHTC-152-16	1	LHTC-152-24	1
17	Jaw, Right Hand	LHTC-150R-08	1	LHTC-150R-10	1	LHTC-150R-16	1	LHTC-150R-24	1
18	Block, Bearing Short	LHTC-153-MSA-08	1	LHTC-153-MSA-10	1	NONE	1	LHTC-153-MSA-24	1

## Recommended Spare Parts List for BUDGIT Steel Frame Low Headroom Plain and Hand Geared Trolley Hoists

Certain parts of your hoist will, in time, require replacement under normal wear conditions. It is suggested that the following parts be purchased for your hoist as spares for future use.

CATALOG NO. \_\_\_\_\_

CAPACITY \_\_\_\_\_

Quantity	Part No.	Description
1	C-9301	Pawl Stud
1	C-908	Pawl Snap Ring
1	C-910	Pawl Spring
1	C-923	Pawl
1 pr.	C-934	Brake Discs
1	C-935	Ratchet
2	C-9329	Load Wheel only for 1-1/2, 2, 3, 4, 8, or 16-ton capacity units
C-9274	C-9374	Bull Gear Shaft (Sold in combination only for 5 & 6, 10 & 12.
2	C-9390	Bull Gear 20 & 24-ton capacity units.)
	C-9329	Load Wheel
2 pcs	C-938-2	_____ " _____ " lineal load chain
2 pcs.	C-38	_____ " lineal load chain C-38-1/2A or C-38-3 Required
	C-9203-P	Plain Trolley only Depends Upon Hoist Capacity
	C-9203-G	Geared Trolley Wheel only

**NOTE:** When ordering parts always furnish:

1. Provide complete identification data from hoist serial number or nameplate located on the trolley hoist side plate. In the event identification tags are missing, advise hoist capacity and complete beam size on which it operates.
2. Provide part numbers, description, and quantity required.
3. Provide correct shipping destination.

Parts for your hoist are available from your local authorized BUDGIT/TUGIT repair station. For the location of your nearest repair station, write:

**LIFT-TECH INTERNATIONAL, USA**  
414 WEST BROADWAY AVE. • P.O. BOX 769  
MUSKEGON, MICHIGAN 49443-0769

**PHONE TOLL FREE 800-742-9269**  
**FAX 800-742-9270**

or phone: