

BUDGIT[®]
MAN & GUARD[™]
electric hoists

11924



CRANE & HOIST DIVISION • DRESSER INDUSTRIES, INC.
MUSKEGON, MICHIGAN 49443

Printed in U.S.A.

FOREWORD

This book contains important information to help you install, operate, maintain and service your new Electric Hoist. We recommend that you study its contents thoroughly before putting your hoist into use. Then, thru proper installation, application of correct operating procedures, and by practicing the recommended maintenance suggestions you will be assured maximum lifting service from the hoist.

Complete inspection, maintenance and overhaul service is available for **BUDGIT** Electric Hoists at Authorized Repair Stations. See accompanying list. All are staffed by qualified factory-trained service men; have authorized testing equipment; and stock a complete inventory of factory approved **BUDGIT** replacement parts.

Complete replacement parts information is given in Section IX. It will likely be a long time before parts information is needed, therefore, after you have completely familiarized yourself with operation and preventive maintenance pro-

cedures, we suggest that this instruction and parts manual be carefully filed for future reference.

NOTICE: Use only factory approved **BUDGIT** replacement parts, available from Authorized Repair Stations or **BUDGIT** Hoist Distributors.

The "Accident Prevention Manual for Industrial Operations" (8th Edition) by the National Safety Council states:

"Employees who work near cranes or assist in hooking on or arranging loads should be instructed to keep out from under loads. Supervisors should watch closely to see that this rule is strictly followed.

From a safety standpoint, one factor is paramount: conduct all lifting operations in such a manner that if there were an equipment failure, no personnel would be injured. **This means keep out from under raised loads!"**

INDEX		Page
SECTION I	GENERAL DESCRIPTION	
Paragraph 1-1	General	3
Paragraph 1-2	Hoist Service Classification	3
Paragraph 1-3	Basic Construction	3
Paragraph 1-4	Differences Between Models and Sizes	4
Paragraph 1-5	MAN-GUARD Overload Clutch	4
SECTION II	INSTALLATION	
Paragraph 2-1	General	4
Paragraph 2-2	Installation	4-5
Paragraph 2-3	Pre-Installation Checks	5
Paragraph 2-4	Connecting Hoist to Electrical Service	5-6
SECTION III	OPERATION	
Paragraph 3-1	General	6
Paragraph 3-2	Operating Hoist	6
Paragraph 3-3	Pulling and Pivoting Hoist and Load	6
Paragraph 3-4	Upper and Lower Limit Stops	6
Paragraph 3-5	MAN-GUARD Overload Clutch Operation	7
Paragraph 3-6	Operating Precautions	7
SECTION IV	LUBRICATION	
Paragraph 4-1	General	7
Paragraph 4-2	Change Gear Case Oil	7
Paragraph 4-3	Lubricate Load Chain	7-8
Paragraph 4-4	Lubricate Upper Hook and Lower Block Assembly	8
Paragraph 4-5	Lubricate Limit Lever Control Shaft and Gears	8
SECTION V	MAINTENANCE	
Paragraph 5-1	General	8
Paragraph 5-2	Thirty-Day Inspection	8-10
Paragraph 5-3	Six-Month Inspection	11
Paragraph 5-4	Inspection - 5000 Hour or Five Year	11
SECTION VI	TROUBLE SHOOTING CHART	12-13
SECTION VII	DISASSEMBLY AND REASSEMBLY	
Paragraph 7-1	General	13
Paragraph 7-2	Disassembly of Hoist Into Subassemblies	14-17
Paragraph 7-3	Rebuild of Hoist Frame, Sprocket Gear, Sprocket Shaft and Chain Guide	17-19
Paragraph 7-4	Rebuild of Load Brake and Overload Clutch Assembly	19-21
Paragraph 7-5	Rebuild of Lower Block and Load Chain Assembly	21-22
Paragraph 7-6	Rebuild of Electrical Controls and Gear Case Cover Subassembly	22
Paragraph 7-7	Rebuild of Push Button Station and Conductor Cable Assembly	23
Paragraph 7-8	Rebuild of Contactor Assembly (Push Button Models)	23
Paragraph 7-9	Rebuild of Single Phase Motor Assembly	23
Paragraph 7-10	Rebuild of Three Phase Motor Assembly	24
Paragraph 7-11	Reassembly of Hoist From Subassemblies	24
Paragraph 7-12	Testing Hoist	24
Paragraph 7-13	Test Procedure For Checking Operation of Overload Clutch	25
SECTION VIII	WIRING DIAGRAMS	26-31
SECTION IX	REPLACEMENT PARTS	32-66

NOTICE: Information contained in this book is subject to change without notice.

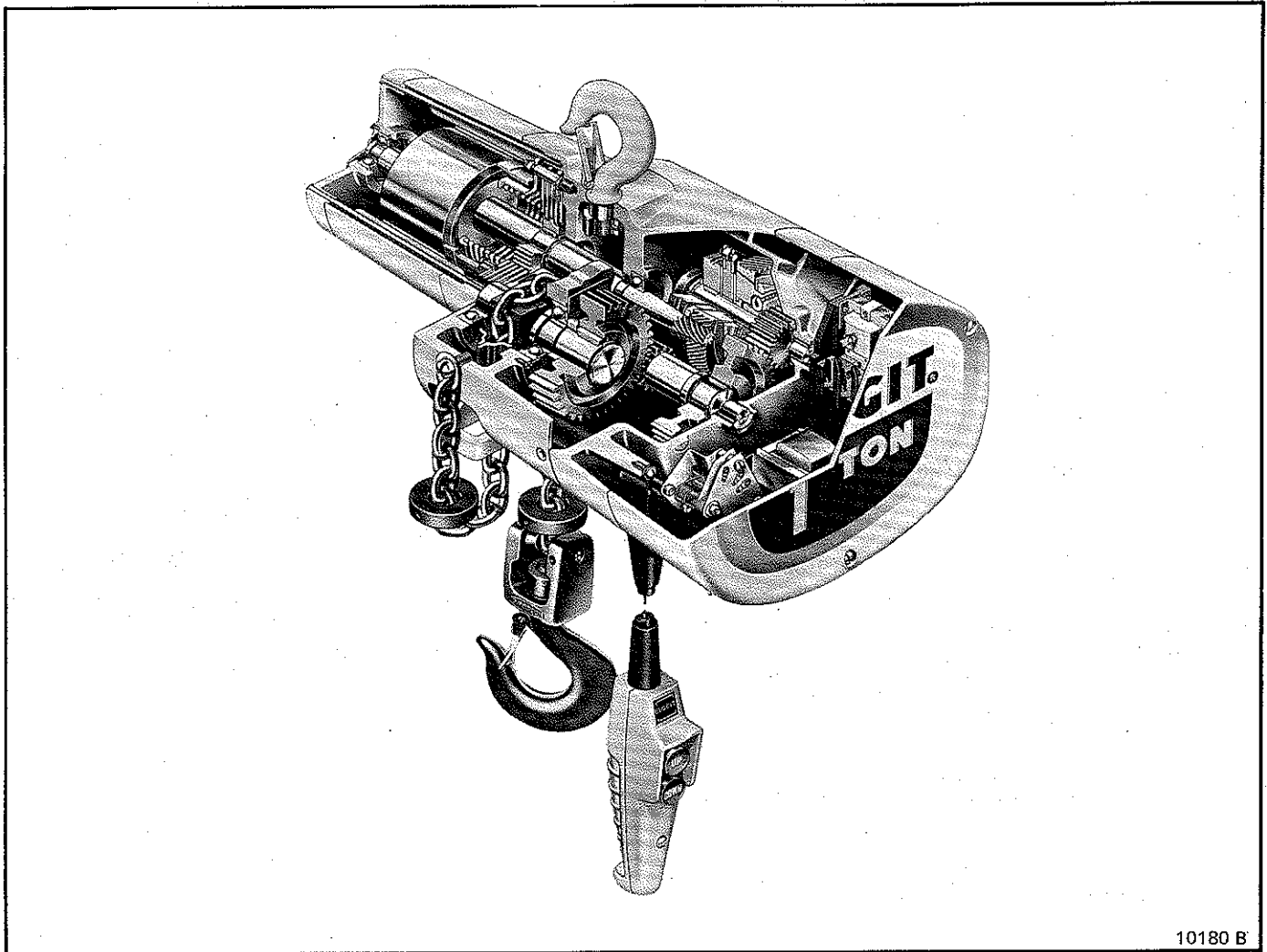

10180 B

Figure 1-1. CUTAWAY VIEW OF TYPICAL BUDGIT ELECTRIC HOIST

SECTION I - GENERAL DESCRIPTION

1-1. GENERAL. BUDGIT Portable Electric Hoists are precision built chain type hoists ranging in five rated load sizes from 1/4 ton thru 3 tons with various lifting speeds and electrical power supplies. In addition to the capacities, there are model variations with roller or coil type load chains, hook or lug type suspension, and single or two speed. In addition to standard models, there are four rated load sizes of Extra Heavy Duty BUDGIT Electric Hoists ranging from 1/4 ton thru 2 tons (suitable for plating hoist service) with various lifting speeds and electrical power. Extra Heavy Duty Hoists are available only with coil type load chains with hook or lug type suspensions.

1-2. HOIST SERVICE CLASSIFICATION

a. Standard single phase hoists are designed to operate at a maximum of 20% "ON-TIME" (motor actually running) and up to 200 motor actuations per hour with mean effective load of 65% of rated hoist load (meets Hoist Duty Class H3*).

b. Standard three phase hoists are designed to operate at a maximum of 40% "ON-TIME" (motor actually running) and up to 400 motor actuations per hour with mean effective

load of 65% of rated hoist load (meets Hoist Duty Class H4*).

c. Extra Heavy Duty Hoists are designed to operate at a maximum of 70% "ON-TIME" (motor actually running) and up to 1200 motor actuations per hour with a mean effective load of 65% of rated hoist load.

*ANSI/ASME HST-IM-1982

Performance standard for Electric Chain Hoists.

1-3. BASIC CONSTRUCTION. All sizes and models of these BUDGIT Electric Hoists are of the same basic design, having many common and interchangeable parts. They consist primarily of an aluminum alloy frame and gear case cover which houses an automatic load brake and gear train. An electric driving motor and disc type motor brake are mounted on the rear of the frame. Electrical control components are mounted on front of the gear case cover and encased by aluminum alloy end cover. An upper hook or lug bracket for suspending the hoist is attached to the top of the frame. Either a special nickel steel roller load chain or alloy steel coil load chain with lower block assembly is employed to raise and lower loads. A block and chain operated limit stop lever is mounted on the bottom of the hoist frame and is connected, by linkage, to a limit switch. Hoist operation is controlled by a pendant push button station.

1-4. DIFFERENCES BETWEEN MODELS AND SIZES.

The main differences between hoist models are in the service classification, type of load chain and the suspension employed. These are described in paragraphs (a) thru (d), below. The differences between sizes of hoists are in the number of gear reductions used and the reeving of the load chain. Two-reduction gearing is used for 1/4 thru 1/2 ton rated load hoists; three-reduction gearing for 1, 2 and 3 ton rated load hoists. On 1/4 thru 1 ton rated load hoists, the load chain is single reeved (one part of chain); on 2 ton rated loads, the chain is double reeved (two parts of chain); on 3 ton rated loads, the chain is triple reeved (three parts of chain).

a. Two different types of load chains are used as the lifting medium, roller chain and coil chain. The roller type chain is a special precision manufactured nickel steel chain. Coil type chain is full-flexing electric welded link chain. Both are especially designed for use in **BUDGIT** Electric Hoists and only factory approved chain of the correct size, pitch, hardness and strength can be used with these hoists.

b. Suspension differences include a conventional hook type mounting and a lug type mounting. Hook suspension allows portability permitting hoist to be easily moved from job to job. Lug suspension permits hoist to be rigidly mounted to overhead structure or attached to **BUDGIT** Rigid Mount Trolleys, affording unusual headroom advantage.

c. Extra heavy duty hoists are adaptations of standard model hoists to permit use in corrosive atmospheres, high ambient temperatures and high duty cycle operation. They are available only in coil chain models in either hook or lug suspension. Construction variations from standard models are as follows:

(1) Load chain is cadmium plated for corrosion resistance.

(2) All exposed aluminum parts are prime painted with corrosion resistant paint.

(3) Push Button Control station is molded polyester and is vapor resistant.

(4) Motor is fan cooled, especially designed for extra heavy duty service. Bearings are lifetime lubricated with high temperature grease.

d. Extra Heavy Duty Hoists are identified by a suffix (-4, -5, -7) after the hoist catalog number stamped on the nameplate located on the motor. Dash 4 indicates hook suspension, dash 5 indicates lug suspension for manual trolleys, and dash 7 indicates lug suspension for motor driven trolleys.

1-5. **MAN-GUARD OVERLOAD CLUTCH.** **BUDGIT** Electric Hoists having a **MAN-GUARD** label on the sides of the electrical compartment cover (figure 1-2) are equipped with an overload clutch that is designed to help guard against excessive overloads. The clutch is built into the load brake gear. It is a cone-friction clutch that connects the first reduction gear (load brake gear) to the load brake output pinion shaft. A Belleville disc spring provides clutch pressure between the gear and its cone shaped gear center. An excessive overload causes the load brake gear to rotate without turning the gear center and output pinion shaft. The clutch is located between the load brake and the motor, thus allowing both load brake and motor brake to function in their normal manner. See paragraph 3-5 for operation.

WARNING

THE MAN-GUARD OVERLOAD CLUTCH IS A PROTECTIVE DEVICE THAT WILL PERMIT OPERATION OF YOUR HOIST WITHIN ITS RATED LOAD AND WILL PREVENT LIFTING OF EXCESSIVE OVERLOADS WHICH CAN CAUSE PERMANENT DEFORMATION OR WEAKENING OF A PROPERLY MAINTAINED HOIST AND/OR ITS SUSPENSION.

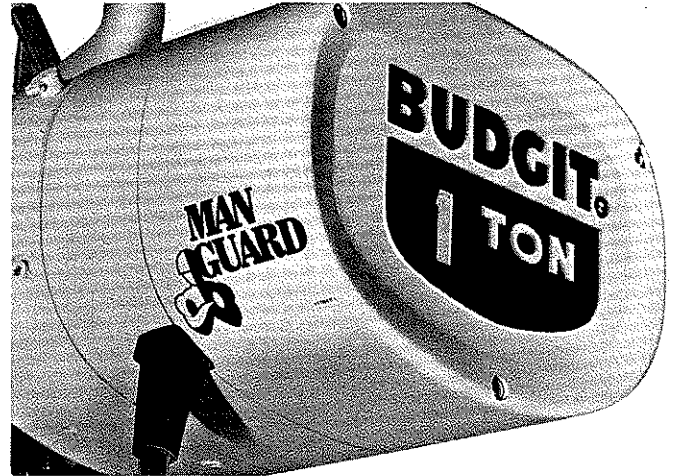

Figure 1-2. MAN-GUARD Hoist Identification

11924

SECTION II - INSTALLATION

2-1. **GENERAL.** **BUDGIT** Electric Hoists are completely lubricated and load tested under their own power before being shipped from the factory. To place hoist in service, attach to suitable overhead suspension (par. 2-2) in area to be used; make pre-installation check (par. 2-3); and connect to nearest electrical service outlet (par. 2-4).

2-2. INSTALLATION.

CAUTION

Lubricate load chain before operating hoist. See paragraph 4-3.

a. On hook suspended hoists, select a suitable overhead support in area hoist is to be used (one capable of holding weight of hoist and its rated load) and hang up hoist. Be certain upper hook is firmly seated in center of hook saddle. Upper hook is equipped with a spring type hook latch; it may be necessary to remove latch to attach hook to support. Replace latch after hoist is installed.

b. On lug suspended hoists, select a suitable overhead support in area hoist is to be used (one capable of holding weight of hoist and its rated load). Mount hoist using thru bolts, of appropriate size, to fit mounting holes in suspension lug at top of hoist frame. (See table below.) The structure

used to suspend hoist must be of sufficient strength to withstand reasonable forces to which hoist and support may be subjected. Hoist must be aligned with load to avoid side pulls.

c. On lug suspended hoists, the suspension lug may be installed for cross mounting (normal conditions) or parallel mounting (special conditions) of the hoist. To rotate hoist 90° follow the instructions below:

(1) On 1/4 thru 1 ton hoists remove suspension lug per instructions in Section VII, paragraph 7-3, c, (1) and figure 7-23. Lift lug from hoist frame, rotate to desired position and replace on locating pins. Insert suspension bolt and nut. Turn nut on top of lug while holding nut inside of hoist frame with drift until grooved pin holes are aligned.

WARNING

Be certain to replace grooved pin thru nut and suspension bolt.

(2) On 2 ton hoists, remove hex socket head screw in lower lock plate. Remove lower lock plate. Rotate suspension lug to selected position and replace lock plate and hex socket head screw.

(3) On 3 ton hoists, the hanger bracket must first be removed from the hoist to provide access to suspension nut per Section VII, par. 7-2, a, (4) and figures 7-2 and 7-3. To remove lug bolt, follow instructions in Section VII, par. 7-3, b, (3). With bolt removed lift lug from hanger and reposition as desired. The lug is located and prevented from turning by integral lugs on adjacent surfaces of the lug and the hanger. Re-install lug bolt, spherical washers and nut. Align hole in nut and lug bolt. Reassemble hanger bracket to hoist.

WARNING

Be certain to replace grooved pin thru nut and lug bolt.

d. On rigid mount trolley suspended hoists, the trolley side plates must be properly spaced so trolley will fit I-beam on which hoist will operate. Adjustment for various I-beam sizes is accomplished by rearrangement of spacer washers on thru bolts which connect trolley side plates to suspension lug on hoist. Refer to instruction sheet furnished with BUDGIT Rigid Mount Trolleys for complete instructions.

SUSPENSION LUG BOLT SIZES AND SPACING

Hoist Rated Load Tons	Bolt Diameter Inches	Distance Between Holes Inches
1/4, 1/2, & 1	5/8	3-1/8
2	1	5
3	1-1/4	6

2-3. PRE-INSTALLATION CHECK.

Check Oil Level. (Fig. 4-1) The gear case has been

filled with oil, to the proper level at the factory. However, the oil level should be checked before hoist is operated. Remove and discard felt shipping plug from oil filler on side of hoist frame. Check oil level by removing oil level plug (side of frame). Observe if oil level is even with bottom of tapped hole. If it is not, add oil, as specified in paragraph 4-2, c. Also check load chain. Be sure it is properly lubricated. See paragraph 4-3.

2-4. CONNECTING HOIST TO ELECTRICAL SERVICE.

a. All hoists are equipped with a flexible power cable extending from the hoist. A grounding type male plug or permanent connection in an outlet box may be used for connecting hoist to power supply. See table (fig. 2-1) for branch circuit conductor sizes.

H.P.	Power Supply	AWG WIRE SIZE					
		#16	#14	#12	#10	#8	#6
1/4	115-1-60	*	55	90	145	230	370
	230-1-60	*	245	395	620	995	
	208, 230-3-60	145	235	375	590		
	460, 575-3-60	730	1160				
1/2	115-1-60	*	45	70	115	185	290
	230-1-60	*	195	315	495	790	
	208, 230-3-60	145	235	375	590		
	460, 575-3-60	730	1160				
1	230-1-60	*	120	190	305	475	
	208, 230-3-60	105	170	270	430		
	460, 575-3-60	485	770				
2 1/2	208, 230-3-60	41	66	108	170		
	460, 575-3-60	164	264				

* Do not use.

Figure 2-1. Branch Circuit Conductor Size. Maximum length in feet for minimum wire size based on Horsepower and power supply. Wire size for entire length of branch circuit and permanent wiring to main feeder. Power supply measured at hoist, while running and with normal load, must not vary more than ±5% of voltage on motor nameplate.

b. Follow local & National Electrical Codes when providing electrical service to hoist. Connect power wires in accordance with appropriate wiring diagram shown in Section VIII. Power supply must be the same voltage, frequency and phase as specified on the hoist nameplate.

WARNING

The green wire provided in the power supply cable is a grounding wire and must be connected to a proper ground. (Follow local code requirements and/or National Electrical Code Par. 250-57 or 250-59).

c. Dual voltage hoists with re-connectable 230/460 volts, 3 phase, 60 hertz are (unless otherwise specified on customer's order) shipped from factory pre-connected for operation on 460 volts. If hoist is to be operated on 230 volts convert wiring by changing connections on terminal board. With hoist disconnected from power source, remove electrical compartment cover and reconnect terminal board leads as directed in figure 8-5. Also refer to Wiring Diagram, figure 8-4.

WARNING

Three phase hoists must be properly phased each time they are installed or moved to a new power source or when service is performed on mainline. Unless this is done, serious damage to the hoist can occur with resulting hazard to operator and load.

d. To properly phase the hoist follow these steps:

(1) Temporarily connect hoist to power source.

(2) Operate "UP" button briefly to determine direction of travel.

(3) If hook raises, phase is correct and temporary connections should be made permanent.

(4) IF HOOK LOWERS, HOIST IS "REVERSED PHASED" AND MUST BE CORRECTED BY INTERCHANGING ANY TWO LEADS AT POWER SOURCE CONNECTION. DO NOT CHANGE INTERNAL WIRING OF HOIST.

(5) The Instruction Tag for proper phasing should be removed from the "DOWN" push button after it has been determined that hoist is correctly phased.

e. For connecting hoist to a motor driven trolley, refer to instructions furnished in trolley manual.

SECTION III - OPERATION

3-1. GENERAL. Operation of BUDGIT Electric Hoists is controlled by a push button station suspended from the hoist electrical compartment. The station has a built-in mechanical interlock to prevent depressing both buttons simultaneously.

3-2. OPERATING HOIST.

a. Depress push button marked "UP" to raise load.

b. Depress push button marked "DOWN" to lower loads.

c. Jogging the push buttons will give "hairline" load movement. The quickness of the depressing motion will determine the amount of movement. Excessive use of this "jogging" feature will cause premature burning of contact points, motor overheating, and rapid motor brake wear.

3-3. PULLING AND PIVOTING HOIST AND LOAD.

a. The push button station conductor cable has a built-in strain cable suitable for pulling trolley suspended hoists when not loaded. Do not use for pulling bridge cranes. Push on load or load chain or use a hand geared or motor driven type trolley to traverse loaded hoists.

b. To pivot hoist and load, push on one corner of load. The lower hook will pivot thru 360 degrees to permit load to be swung to the desired position. The upper hook (hook suspension models) is also designed to rotate so that side pulls will swing hoist to face load, thus reducing side thrust.

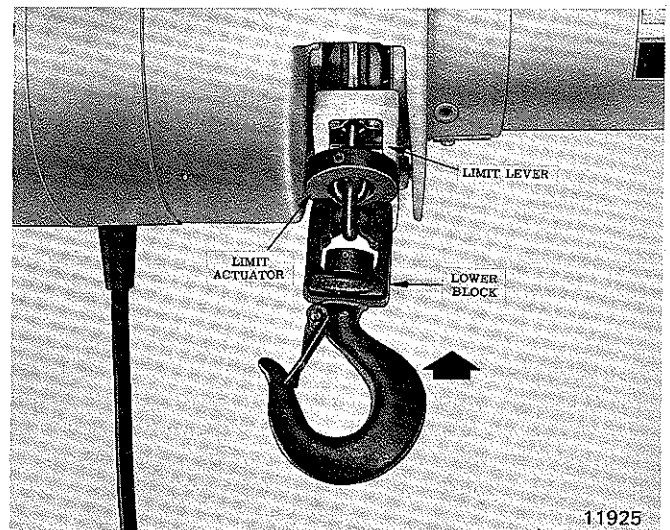

Figure 3-1. Limit Lever Being Tripped By Actuator Above Lower Block on Single Line Hoist.

3-4. UPPER AND LOWER LIMIT STOPS. A lower block and chain operated limit stop is provided to guard against overtravel of load in either raising or lowering direction, which can cause damage to hoist. When highest position is reached, limit actuator on the load chain, above the lower block, trips the limit lever (fig. 3-1). When lowest position is reached, a limit actuator on the tail end of load chain trips the limit lever (fig. 3-2). The limit lever is connected to a limit switch that automatically stops the hoist motor. This is intended as a safety device and should not be used on a routine basis to stop travel of lower block or shut off hoist.

NOTE: On lug type, coil chain hoists, the limit lever may be tripped by the load chain during side pulls. Load must be lined up with hoist. If moderate side pulls cannot be avoided, rotate hoist 90° so it is mounted with side of hoist facing direction of side pull. See appropriate instruction in Section II, paragraph 2-2, c.

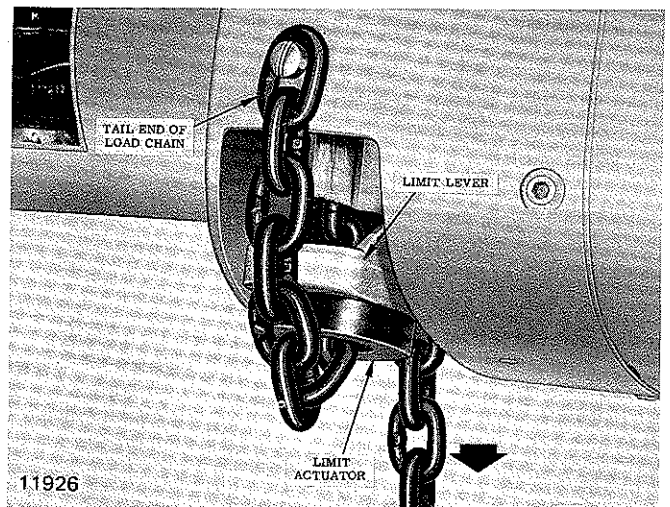

Figure 3-2. Limit Lever Being Tripped By Actuator on Tail End of Load Chain.

3-5. MAN-GUARD OVERLOAD CLUTCH OPERATION. The overload clutch is factory preset at assembly so that the

hoist will lift its full rated load but will refuse to lift overloads within a range of 110 percent rated load to 180 percent rated load. If the load to be lifted exceeds the clutch factory setting, the motor will continue to run and will rotate the load brake gear without lifting the load. Whenever this occurs, immediately release the "UP" push button to prevent overheating of the clutch friction surfaces and motor.

NOTICE

Always know load to be lifted. Dresser Industries does not recommend lifting loads greater than the rated load of your hoist.

3-6. OPERATING PRECAUTIONS.

WARNING

Equipment covered herein is not designed or suitable as a power source for lifting or lowering persons. Do not use as an elevator.

Safe operation of an overhead hoist is the operator's responsibility. Listed below are some basic rules that can make an operator aware of dangerous practices to avoid and precautions to take for his own safety and the safety of others. Observance of these rules in addition to frequent examinations and periodic inspection of the equipment may save injury to personnel and damage to equipment.

- a. Personnel not physically fit or properly qualified, shall not operate hoist.
- b. Operate hoist cautiously to become familiar with its performance.
- c. Do not lift loads greater than the hoist rated capacity.
- d. Never lift or transport a load until all personnel are clear. Never lift people on hook or load.
- e. Stand clear of all loads and never travel loads over people.
- f. When lifting load make certain it is free to move and will clear all obstructions.
- g. Do not divert attention from load while operating hoist. Never leave a suspended load unattended.
- h. Do not operate hoist unless upper and lower limit switch stops are operating properly.
- j. Do not use limit switch stops as normal operating stops. This is a safety device only.
- k. Take up chain slack carefully to avoid jerking load, possibly overloading hoist.
- i. Never use hoist chain as a sling or electrical ground for welding.
- m. Always be sure there is no twist in coil load chain. On 2 & 3 ton coil chain hoists, check to see that lower block is not capsized between strands of chain.
- n. Avoid operating hoist when hook is not centered under hoist. Be sure that hoist trolley or other support mechanism is correctly positioned for handling the load before lifting.
- o. Do not operate hoist with twisted, kinked, badly worn or damaged chain.
- p. Do not operate damaged or malfunctioning hoist.
- q. Always operate hoist within recommended duty cycle and do not "jog" unnecessarily.

r. Conduct regular visual inspections for signs of damage or wear.

s. Observe recommended inspection and maintenance procedures.

t. Never operate hoist with hooks that have opened up. See Figures 5-5 and 5-6.

u. Do not remove or obscure warning labels.

v. The supporting structure or anchoring means shall have a load rating at least equal to that of the hoist.

w. Hoists shall not be used in locations that will not allow operator movement to be free of the load.

x. The operator shall insure that he has firm footing or is otherwise secured before operating the hoist.

y. The load slings or other approved devices shall be seated properly in the saddle of the hook and the hook latch shall be closed before operating hoist.

z. Before lifting a load the operator shall be certain that load is not caught on any obstructions.

aa. When starting to lift or pull, the load should be moved a few inches at which time the hoist should be checked for proper load holding action. The operation shall be continued only after the operator is assured that the hoist is operating properly.

ab. The operator should not leave a loaded hoist unattended at the end of a work shift or for extended periods during the work shift. Where operations are such that this condition cannot be avoided the operator must be assured that the condition does not create a hazard to personnel or property.

ac. Use common sense and best judgment whenever operating a hoist. Observe American National Standard Safety standard, ANSI B30.16, latest issue.

SECTION IV - LUBRICATION

4-1. GENERAL. The lubrication services outlined in paragraphs 4-2 thru 4-5 should be performed at regular intervals to maintain top hoist performance and insure long life. The frequency for lubrication services will depend on the type of hoisting service that hoist is subjected to and should coincide with periodic preventive maintenance inspection. See Section V - Maintenance.

4-2. CHANGE GEAR CASE OIL (Fig. 4-1)

a. Remove drain plug from bottom of hoist frame and drain oil from gear case. Replace plug.

b. Remove oil level plug from side of hoist.

c. Refill gearcase thru oil filler to proper level (bottom of oil level plug hole) using Automatic Transmission Fluid - DEXRON[®] Type. This is an all-weather oil available from all major oil companies. 1-1/2 pints of oil are required.

[®] Registered trademark of G.M.C.

d. Reinstall oil level plug.

4-3. LUBRICATE LOAD CHAIN. A small amount of lubricant will greatly increase load chain life, therefore, chain should not be allowed to run without lubricant. Chain should be cleaned and lubricated as directed in paragraphs a. and b. below, depending upon type of chain. User should set up a regular schedule for chain lubrication after observing operating conditions for a few days.

WARNING

Before performing any internal work on hoist, be certain power is shut off. Lock main service switch in the open position.

SECTION V - MAINTENANCE

5-1. GENERAL. Preventive maintenance services required on **BUDGIT** Electric Hoists are for the most part, simple periodic inspection procedures to determine condition of hoist components. Below are suggested inspection procedures, based on daily average hoist usage.

5-2. THIRTY-DAY INSPECTION. Hoist may be left suspended.

a. Inspect Load Chain.

(1) Operate hoist under load and observe operation of chain over sprocket in both directions of chain travel. Chain should feed smoothly into and away from the sprocket. If chain binds, jumps or is noisy, first see that it is clean and properly lubricated. If trouble persists, inspect chain as outlined below, depending on type of chain.

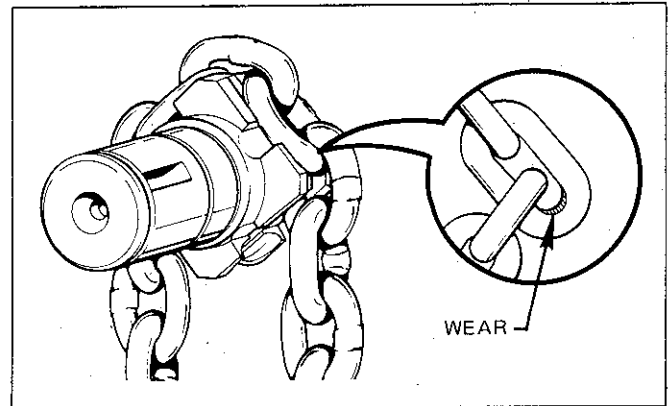

Figure 5-1. Check Chain Wear at Bearing Surfaces Between Links.

(2) **Coil Type Load Chain.** Clean chain for inspection. Examine visually for gouges, nicks, weld splatter, corrosion or distorted links. Slacken chain and check bearing surfaces between links for wear, figure 5-1. Greatest wear will often occur at sprocket at high or low point of lift, particularly when hoist is subjected to repetitive lifting cycles. Case hardness of chain is about .015" deep. Chain must be replaced before the case is worn thru. Also check chain for elongation using a vernier caliper (Figure 5-2). Select an unworn, unstretched section of chain (usually at slack or tail end) and measure and record the length over the number of chain links (pitches) indicated in figure 5-2. Measure and record the same length of a worn section in the load side of the chain. Obtain the amount of wear by subtracting the measurement of the unworn section from the measurement of the worn section. If the result (amount of wear) is greater than the amount specified in the "ALLOWABLE CHAIN WEAR"

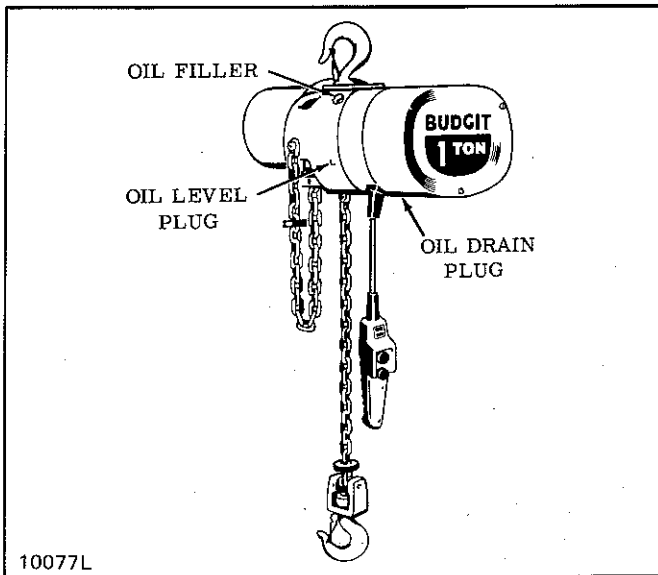

Figure 4-1. Location of Oil Filler and Plugs

a. **Coil Chain.** Under ordinary conditions only weekly attention will be necessary. Under hot and dirty conditions it may be necessary to clean chain at least once a day and lubricate it several times between cleanings. Thoroughly clean chain with an oil solvent and relubricate by coating it lightly with graphite suspension oil. Make sure that lubricant coats wear surfaces between links. On Extra Heavy Duty Hoists load chain should be cleaned and lubricated daily.

b. **Roller Chain.** Under ordinary conditions only monthly attention will be necessary. Under hot and dirty conditions weekly attention may be required. Thoroughly clean chain with an oil solvent and apply a good grade of S.A.E. #20 motor oil. Wipe off excess oil. When subjected to excessive moisture or corrosive atmospheres, DO (dripless oil) lubricant from American Grease Stick Company is recommended for use on roller chain in place of regular motor oil.

4-4. LUBRICATE UPPER HOOK AND LOWER BLOCK ASSEMBLY.

a. Apply a few drops of graphite suspension oil on shank of upper hook where it enters frame.

b. Apply a few drops of graphite suspension oil on shank of lower hook where it enters lower block. Hook rotation bearing may be removed for cleaning and relubricating if necessary. See paragraph 7-5., a., d.

c. On lower block assemblies of 2 & 3 ton capacity hoists, also apply a good grade of bearing grease thru pressure fitting in end of sprocket pin to lubricate bearing in chain sprocket.

d. On 3 ton models lubricate sprocket in hanger bracket with a few drops of graphite suspension oil in hole provided in center of sprocket hub.

4-5. LUBRICATE LIMIT LEVER CONTROL SHAFT AND GEARS

Apply a few drops of graphite suspension oil on limit lever shaft at bearing points.

Chain not conforming to BUDGET hoist specifications may be dangerous as it will not fit in the load sprocket and chain guide correctly, causing damage to hoist, and it will wear prematurely, deform and eventually break.

(3) Removing and Replacing Coil Load Chain.

(a.) Replacement coil load chain is installed by attaching it to tail end of old chain, after disconnecting old chain from side of hoist frame and removing limit actuator. New chain is then run into hoist as old chain is run out. Use open "C" links, figures 5-3 and 5-4, for attaching chains. Links must be identical in size to hoist chain – 1/4" wire size with .745" pitch length for 1/4 thru 1/2 ton models 5/16" wire size with .858" pitch length for 1, 2 & 3 ton models. Be certain that all welds on links of replacement chain face away from center of load sprocket.

(b.) Remove lower block assembly and actuator from old chain and attach them to replacement chain at end which was just run thru hoist. Install limit actuator (as noted

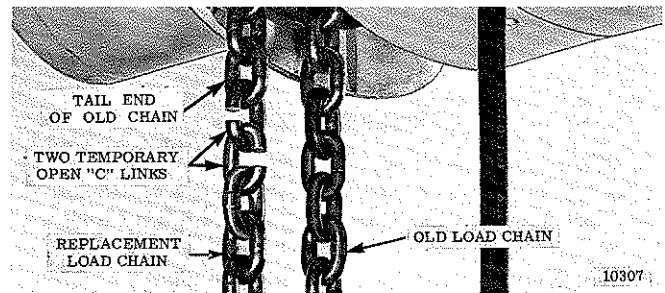

Figure 5-4. Installing Coil Load Chain Using Two "C" Links (1/4, 1/2, 1 ton hoists)

NOTE: In the event the old chain is to be removed from hoist and reinstalled, a short length of chain (about 18" long) must be run into hoist when the old chain is removed. This short length can then be used in the same manner as shown in paragraph 5-2. a.(3). Be sure to use the proper number of open "C" links in order to correctly position end link on tail end of chain to fit anchor at side of hoist frame.

WARNING

When installing coil load chain do not attempt to hand feed chain into hoist, or use a piece of wire in place of the method described herein. To do so may result in serious internal damage to hoist, as coil chain links must be properly seated in chain sprocket before chain is run into hoist.

(4) **Roller Type Load Chain.** Visually check for possible twists, broken links, wear or elongation. Any links that do not flex easily, even when lubricated, may be damaged and should be replaced. Check roller chains for elongation from wear by pulling chain taut and measuring as follows: On RC-625, 625 or H-5 size chain (5/8" pitch), measure distance over a length of 20 pitches (center-to-center distance between 21 rivets) - it must not exceed 12-3/4 inches. On RC-750, H-6 or HF size chain (3/4" pitch) measure length of 16 pitches (center-to-center distance between 17 rivets) - it must not exceed 12-1/4 inches. If chain exceeds the limit, replace damaged section or install new load chain assembly. Check chain for twist. If twist in any 5 foot extension exceeds 15 degrees, replace chain. Check chain for camber. If any section has side bow exceeding 1/4 inch in five feet, replace chain.

CAUTION

Do not assume that load chain is safe because it measures below replacement points given herein. Other factors, such as those mentioned in visual checks above, may render chain unsafe or ready for replacement long before elongation replacement is necessary. **Do not attempt to splice the chain to replace worn or damaged sections unless you have the required equipment to properly spin rivet heads. It is suggested that you have this done by an authorized BUDGIT Repair Station that is equipped with the necessary special tools.**

WARNING

When replacing roller type load chain, use only factory approved chain conforming to factory specifications for material, hardness, tensile strength, size and construction. BUDGIT Hoist Roller chain is specially designed for hoisting service and is the only type roller chain that can safely be used with BUDGIT electric hoists. Chain not conforming to BUDGIT Roller Chain specifications may be dangerous as it will not withstand heavy impact loads and does not have adequate tensile strength.

(5) Check anchor end of chain at side of hoist frame for damage to last link, also connecting link on roller chain hoists. Replace damaged parts.

(6) Check connection of chain to lower block on 1/4 thru 1 ton and 3 ton hoists. Replace parts showing evidence of damage, twisting or elongation.

(7) Check connection of chain to anchor inside hoist frame on double-reeved, 2-ton hoists. Replace parts showing evidence of damage, twisting or elongation. (Also see Sec. VII, par. 7-2a, 2).

(8) Lubricate load chain before using hoist. See par. 4-3, Section IV.

b. Inspect Lower Block.

(1) Check for bent or distorted hook. If hook is opened beyond the dimension given in figure 5-5, it must be replaced. Also check to see that hook swivels and is free to pivot. Lubricate these points if necessary.

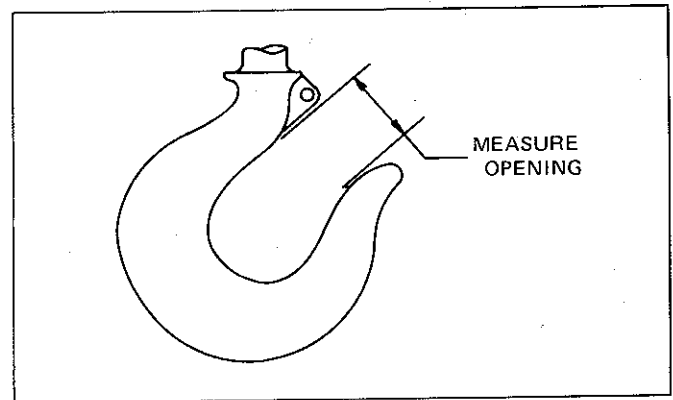

HOIST RATED LOAD (TONS)	HOOK THROAT OPENING	
	NORMAL OPENING	REPLACE HOOK IF OPENING IS GREATER THAN
1/4, 1/2	1-1/8	1-1/4
1	1-1/4	1-7/16
2	1-3/8	1-9/16
3	1-1/2	1-11/16

Figure 5-5. Lower Hook Opening

(2) On 2-ton hoists, check sprocket and bearing in lower block for freedom of movement and signs of damage. Lubricate if necessary. Replace damaged parts.

(3) Check hook latches. Replace damaged or bent latches or broken springs.

CAUTION

Hooks, upper or lower, damaged from chemicals, deformation or cracks or having more than 15 percent in excess of normal throat opening or more than 10 degrees twist from the plane of the unbent hook, or opened, allowing the hook latch to bypass hook tip must be replaced.

Any hook that is twisted or has excessive throat opening indicates abuse or overloading of the hoist. Other load bearing components of the hoist should be inspected for damage. (See Section V, par. 5-2, d, (2) below).

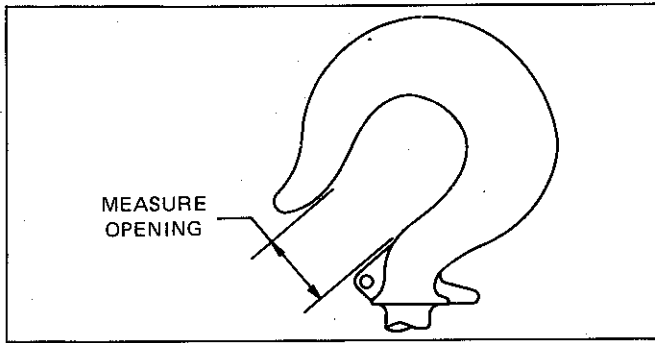

HOIST RATED LOAD (TONS)	HOOK THROAT OPENING	
	NORMAL OPENING	REPLACE HOOK IF OPENING IS GREATER THAN
1/4, 1/2	1-1/8	1-1/4
1	1-1/4	1-7/16
2	1-3/8	1-9/16
3	1-1/2	1-11/16

Figure 5-6. Upper Hook Opening

c. Inspect Upper Suspension.

(1) On hook suspended models, check for bent or distorted hook. If hook is opened beyond the dimension given in figure 5-6, it must be replaced. Also check to see that hook pivots. Lubricate if necessary.

(2) On lug suspended models, check condition of suspension lug. Replace lug if damaged or cracked. Check to see that lock plate is in place on lug and screw holding it is tight.

(3) On 2-ton hoists, check to see that upper lock plate securing hook or lug bushing is in place and screws holding it are tight. Lubricate hook shank.

(4) Check hook latch. Replace damaged or broken parts.

d. Inspect Motor, Frame and Electrical Compartment Cover.

(1) Check to see that bolts securing motor to frame are tight. Also check for any visible damage to motor, such as a cracked end bell or dented stator housing. Replace damaged parts.

(2) Check hoist frame for signs of visible damage. If frame shows evidence of fracture, the hoist should be disassembled and inspected for further signs of damage from possible overloading. Replace damaged parts. Also check condition of limit lever.

(3) Check for possible damage to electrical compartment cover. Be sure screws holding cover are tight.

e. Check Oil Level. Remove oil level plug (fig. 4-1). If oil level is not even with bottom of tapped hole, add Automatic Transmission Fluid, DEXRON[®] Type, to bring to proper level.

5-3. SIX-MONTH INSPECTION OR 500-750 HOURS OF OPERATION. Hoist may be left suspended.

a. Inspect Electrical Controls. Shut off power supply to hoist and remove electrical compartment cover from hoist. Use caution as some covers contain counterweights. Two speed hoists with a 2-1/4 horsepower motor have an externally

mounted counterweight at the electrical compartment cover.

(1) Check all wiring and terminals. Insulation should be sound and terminals securely crimped to wires. Terminal screws should be tight and plug-type terminals completely mated. Replace terminals or wires as necessary.

(2) Check control circuit transformer for evidence of overheating. Replace if necessary.

(3) Check control shaft centering spring by operating limit lever. If limit lever does not return to neutral position after it is tripped, the spring is probably broken or control shaft is bent. Replace broken or damaged parts.

(4) Check limit switch to see that wires are securely soldered and mounting screws are tight.

(5) Check contactor solenoid coils and replace coils if they show evidence of overheating.

(6) Check control cable wire strain reliever to see that it is in good condition and securely attached to gear case cover. Replace rubber strain reliever grommets if damaged.

b. Change Gear Case Oil. See Section IV, par. 4-2.

c. Relubricate Load Chain. See Section IV, par. 4-3.

d. Lubricate Upper Hook and Lower Block. See Section IV, par. 4-4.

e. Lubricate Limit Lever Control Shaft. See Section IV, par. 4-5.

5-4. INSPECTION: 5000 HOURS "ON" TIME OR 5 YEARS ELAPSED TIME. Hoist must be removed from overhead suspension.

a. Disassemble Hoist into Subassemblies. Follow procedure outlined in Section VII, paragraph 7-2.

b. Motor shaft oil seal, sprocket shaft bearing and seal, guide pin "O" rings and all gaskets should be replaced.

c. Inspect Load Brake and Overload Clutch. Disassemble load brake and clutch assembly as outlined in paragraph 7-4. Friction discs should be discarded and replaced with new discs. Check load brake friction surfaces on flange, ratchet assembly and gear clutch cone. Replace parts if badly scored or worn. Check condition of pawl and ratchet assembly. If pawl, ratchet teeth or pawl spring are broken, damaged or badly worn, replace complete assembly. Check contact faces of load brake cam and gear clutch cone. Brake gear and pinion teeth should be inspected for wear or broken teeth. Clean parts thoroughly with an oil solvent before reassembly.

NOTE: The overload clutch assembly should not be disassembled as it is preset at the factory to provide proper clutch pressure for a specific hoist capacity range. If there is evidence of the clutch slipping or wear or damage to the clutch components, the complete clutch assembly should be replaced or sent to an authorized **BUDGIT** Hoist Repair Station to be rebuilt and properly adjusted to factory specifications.

d. Inspect Sprocket and Intermediate Gears.

(1) On 1, 2 and 3 ton hoists, check condition of gear teeth on intermediate gear and pinion shaft assembly. Re-

place worn or damaged parts.

(2) Check condition of teeth or pockets on chain sprocket (all capacities). Replace worn or damaged parts.

e. **Inspect Motor Brake.** For access to motor brake parts, except for two speed, remove motor assembly as outlined in paragraphs 7-2, d. Then, remove brake parts following instructions given for the specific type brake, depending upon model of hoist. Check braking surfaces for wear and scoring. Replace badly worn or scored parts. Check to see that plate support pins inside frame are tight. Check large compression

spring and spring plunger. Replace parts that are worn or damaged.

For two speed hoist, remove brake housing screws, housing, support plate screws, support plate assembly, friction disc and stationary discs. Check braking surfaces for wear and scoring. Replace badly worn or scored parts.

f. **Reassemble and Test Hoist.** Reassemble hoist from subassemblies following procedure outlined in paragraph 7-11. After assembly is complete, test hoist as outlined in paragraphs 7-12 and 7-13.

SECTION VI - TROUBLE SHOOTING

Trouble	Probable Cause	Remedy
6-1. Hoist Will Not Operate.	<ul style="list-style-type: none"> a. No power to hoist. b. Wrong voltage. c. No control voltage. d. Loose or broken wire connections in hoist electrical system. e. Contactor assembly not functioning. f. Motor burned out. 	<ul style="list-style-type: none"> a. Check switches, circuit breakers and connections in power supply lines. Check power collectors. b. Check voltage required on motor data plate against power supply. c. Check transformer fuse. If blown, check for grounding and/or short in the push button station. Check the transformer coil for signs of overheating. Replace transformer if burned out. Verify the transformer secondary is the same voltage as the coils to which it is connected. d. Shut off power supply, remove electrical cover from hoist and check wiring connections. Also check connections in push button station and limit switches. e. Check contact points. Replace if excessively burned or pitted. Check for burned out solenoid coil. See that necessary jumper wires are properly installed. f. Replace motor. On single-phase motors the centrifugal switch or capacitor may be defective.
6-2. Hook Moves in Wrong Direction.	<ul style="list-style-type: none"> a. Reverse phasing on three-phase hoists. b. Hoist wired wrong. 	<ul style="list-style-type: none"> a. Interchange any two of three power supply line leads. Do not change green ground lead. Refer to Section II, par. 2-4. b. Check wiring connections with appropriate wiring diagram.
6-3. Hook Will Raise But Not Lower.	<ul style="list-style-type: none"> a. "DOWN" electrical circuit open. b. Contactor assembly not functioning. c. Push button inoperative. d. Load brake locked up and overload clutch slipping. 	<ul style="list-style-type: none"> a. Check for loose connections. See that necessary jumper wires are properly installed on contactor. Check limit switch condition and electrical connections. b. See that necessary jumper wires are properly installed. Verify that the contactor armatures are free to move. If binding occurs replace contactor. Check for burned out contactor coils. c. Check push button contacts and wires. d. Consult Authorized BUDGIT Hoist Repair Station.

SECTION VI - TROUBLE SHOOTING (Continued)

Trouble	Probable Cause	Remedy
6-4. Hook Will Lower But Not Raise.	<ul style="list-style-type: none"> a. Excessive Load, causing overload clutch to slip. b. Overload clutch out of adjustment. c. "UP" electrical circuit open. d. Contactor assembly not functioning. e. Push button inoperative. 	<ul style="list-style-type: none"> a. Reduce loading to rated load of hoist, as shown on nameplate. b. Test hoist and replace clutch if hoist will not lift rated load. c. Check for loose connections. See that necessary jumper wires are properly installed on contactor. Check limit switch condition and electrical connections. d. See that necessary jumper wires are properly installed. Verify that the contactor armatures are free to move. If binding occurs replace contactor. Check for burned out contactor coils. e. Check push button contacts and wires.
6-5. Hoist Will Not Lift Rated Load.	<ul style="list-style-type: none"> a. Low voltage. b. Overload clutch out of adjustment. c. Motor brake not releasing. 	<ul style="list-style-type: none"> a. See that power supply is same voltage listed on motor data plate. Check size of power supply lines. Refer to fig. 2-1. b. Remove and replace clutch assembly. Refer to Section IV, par. 7-2 and 7-4. c. Remove motor and check brake components. Refer to Section VII, par. 7-2, d, e and f. For two speed hoists refer to par. 5-4, e.
6-6. Excessive Drift When Stopping.	<ul style="list-style-type: none"> a. Excessive load. b. Motor brake not holding. c. Load brake not holding. 	<ul style="list-style-type: none"> a. Reduce loading to rated load, shown on nameplate. b. Remove motor and clean and inspect brake linings. Refer to Section V, par. 5-4. c. Remove load brake and inspect parts. Refer to Section V, par. 5-4.
6-7. Hoist Motor Overheats.	<ul style="list-style-type: none"> a. Excessive load. b. Excessive duty-cycle. c. Excessive "jogging". d. Wrong voltage. e. Centrifugal switch on single-phase motors not opening starting winding. f. Defective motor or worn needle bearings in hoist frame. g. Motor brake not releasing. 	<ul style="list-style-type: none"> a. Reduce loading to rated load of hoist, shown on nameplate. b. Reduce frequency of lifts. c. Reduce frequency of jogs. d. Check voltage rating on motor data plate against power supply. e. Refer to Section VII, par. 7-9, b (5) (b). Remove motor and inspect switch. f. Disassemble hoist and inspect for defective, worn or damaged parts. g. Remove motor and check brake components. Refer to Section VII, par. 7-2, d, e and f. For two speed hoists refer to par. 5-4, e.

SECTION VII - DISASSEMBLY AND RE-ASSEMBLY

7-1. GENERAL

a. The following disassembly and reassembly instructions apply to all models in the line of **BUDGIT** Electric Hoists with 4 digit catalog numbers and equipped with **MAN-**

GUARD overload clutch. Where needed, variations to instructions are provided to cover differences between models (suspensions, load chain, rated load sizes and motor voltage ratings), with applicable models specifically noted.

b. A complete teardown procedure is given, however, if only certain parts require repair or replacement, a partial

teardown may be performed using the applicable portions of the instructions.

c. For easier handling during disassembly, the following disassembly steps may, where conditions permit, be completed before hoist is removed from its overhead suspension or disconnected from its power supply: Remove chain container, if hoist is so equipped; remove lower block and load chain assembly, following procedure outlined in paragraph 7-2, a. Drain and discard gear case oil, by removing plug at bottom of frame.

d. These hoists contain precision machined parts and should be handled with care at disassembly and at re-assembly. When removing or installing parts with press fits, be careful to apply pressure evenly. On ball bearings, apply pressure to face of inner or outer race, whichever is adjacent to mating part. This will avoid damage to bearing races from brinelling by pressing thru bearing balls. Apply a thin film of sealant to parts having a press fit when they are installed.

7-2. DISASSEMBLY OF HOIST INTO SUBASSEMBLIES

a. Removal of Lower Block and Load Chain Subassembly.

(1) On models with single-reeved load chains (1/4 thru 1 ton capacities) disconnect tail end of load chain from anchor at side of frame. Remove spring clip and connecting link attaching chain to anchor on roller chain models (fig. 7-1). Remove fillister head screw holding end link to frame on coil chain models. Remove grooved pin from the limit actuator and pull it off end of chain. With hoist connected to power supply, run chain out of hoist by operating in "lowering" direction. (See note following paragraph (2) below and note in Sec. V, par. 5-2, a, (3) for inserting short length of chain.)

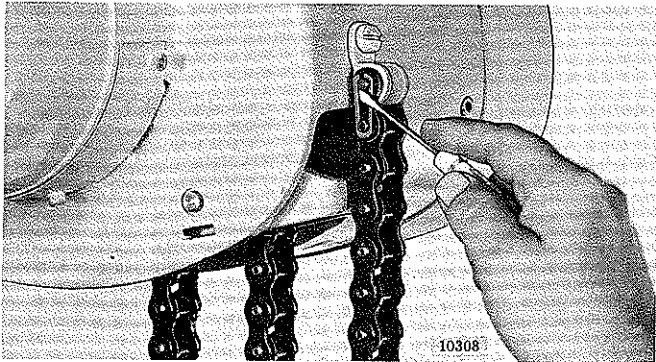

Figure 7-1. Removing Spring Clip from Connecting Link at Tail End of Load Chain (Roller Chain Models)

(2) On models with double-reeved load chains (2 ton hoists) disconnect tail end of load chain from anchor at side of hoist frame and remove limit actuator as in (1) above, run chain out of hoist by operating it in "lowering" direction, and disconnect opposite end of load chain from anchor inside hoist frame. To disconnect this end of chain, remove cotter pin from end of anchor pin, press pin from anchor and withdraw chain. On roller chain models the anchor in hoist frame must be rotated about 90° to permit removal of anchor pin. The drive pin securing threaded end of anchor in upper block assembly (at top of frame) must be removed in order to rotate the anchor.

NOTE: If hoist is inoperative it will be necessary to wait until after load brake is removed (par. c., below), then the chain can be pulled thru the hoist by hand.

(3) On triple-reeved 3 ton coil chain hoists, remove retaining ring and connecting link pin as shown in figures 7-33 and 7-34. Remove connecting link with chain from

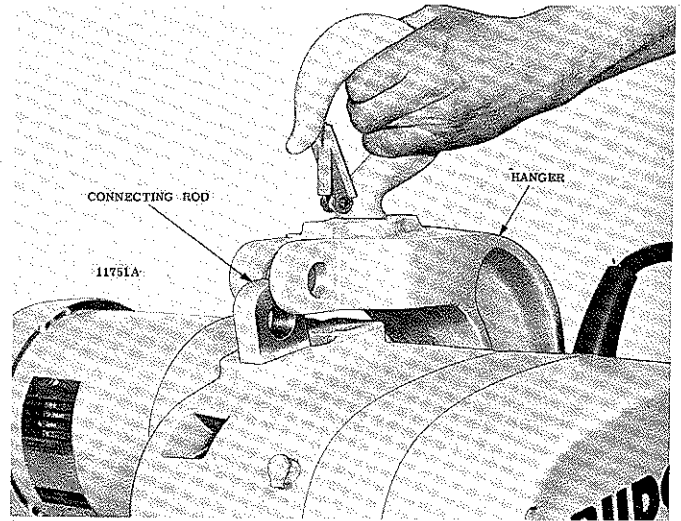

Figure 7-2. 3 Ton Hanger Bracket Connection Pin Removed

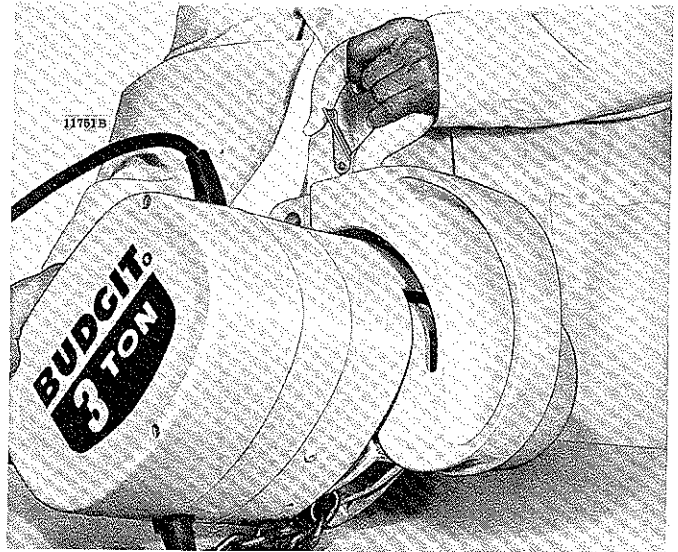

Figure 7-3. Removing 3 Ton Hanger Bracket from Hoist Frame

lower block. To remove connecting link from chain, take out cotter key and push anchor pin from connecting link. Chain can now be pulled thru hanger bracket and lower block. Unfasten tail chain from hoist frame, remove limit actuator, and if power is available, operate hoist in lowering direction to remove chain. (See note in Sec. V, par. 5-2, a, (3) for inserting short length of chain). If hoist is inoperative see note below but be sure to install short length of chain into hoist before removing load chain.

NOTE: If hoist is inoperative it will be necessary to remove load brake (par. c., below) so chain can be pulled thru the hoist by hand.

(4) To remove 3 ton hanger bracket from hoist, remove retaining ring and connecting rod pin (see figure 7-2). Rotate hoist approximately 45° (see figure 7-3) and hanger will slip free from hoist frame.

b. Removal of Electrical Compartment Cover, Electrical Controls and Gear Case Subassembly.

(1) Disconnect hoist from power source. Remove three cover retaining screws and lift off cover (figure 7-4). Cover screws have retaining rings which hold them in cover. Use caution as some covers contain counterweights. Two speed hoists with a 2-¼ horsepower motor have an externally mounted counterweight at the electrical compartment cover.

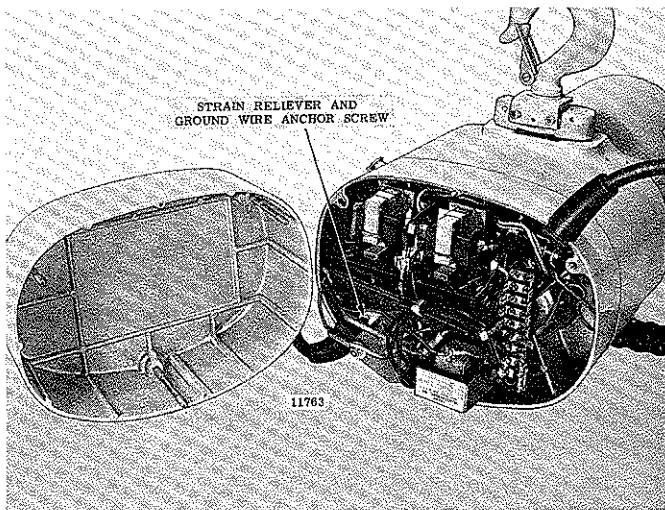

Figure 7-4. View of Push Button Model Hoist with Electrical Compartment Cover Removed

(2) Disconnect push button conductor cable leads at plug-in type connectors that can be pulled apart. Remove screw and washer securing strain reliever (fig. 7-4) and pull the cable and grommet from its slot in gear case cover.

(3) Disconnect power supply flexible cable leads from terminals of contactor. Remove screw attaching ground leads to gear case cover and pull flexible cable and grommet from slot in cover.

(4) Disconnect motor leads from electrical control units. Number of leads depends on type of motor. (See wiring diagrams in Section VIII).

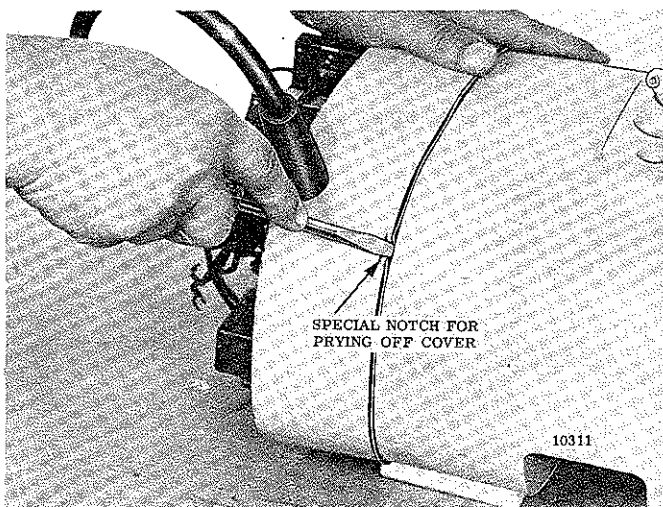

Figure 7-5. Prying Gear Case Cover From Hoist Frame

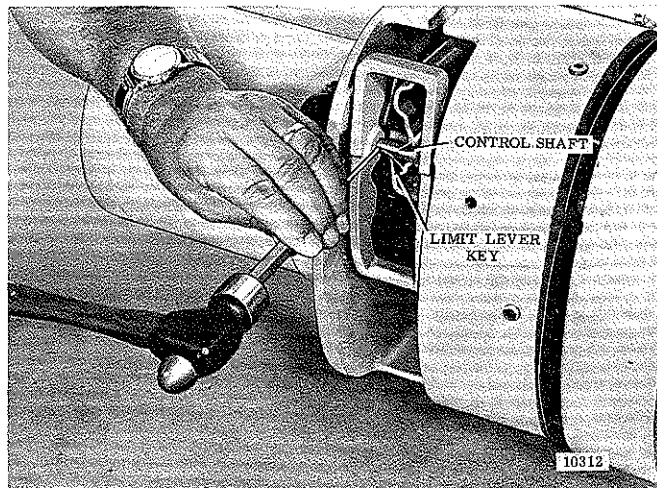

Figure 7-6. Removing Limit Lever Key From Control Shaft

(5) Remove eight hex socket head screws and lockwashers securing gear case cover to hoist frame. Pry gear case cover partially off hoist frame using screw driver at special notches provided at opposite corners of cover (fig. 7-5) to provide access for removing limit lever key from control shaft. Tilt Woodruff key in shaft slot using drift punch (fig. 7-6) and pull out using pliers. Gear case cover with electrical controls attached can now be lifted from frame (figures 7-7). Limit lever will drop free of frame as shaft is removed with cover. Discard gear case cover gasket.

c. Removal of Load Brake and Clutch Assembly and Intermediate Gear Subassembly.

(1) On 1/4 thru 1/2 ton hoists, pull load brake and over-load clutch assembly and the brake shaft washers from inside hoist frame (fig. 7-8). Caution: Grease-retained bearing has 36 rollers (all capacities) and may be reinstalled unless rollers are broken or missing or cup is damaged.

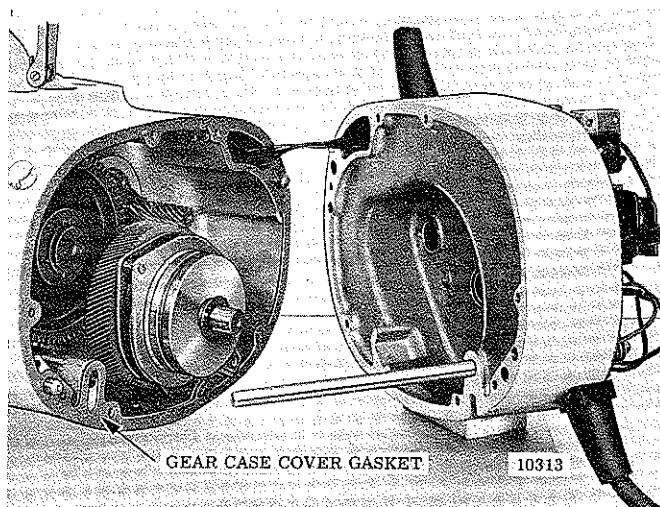

Figure 7-7. Gear Case Cover With Electrical Controls Removed From Frame

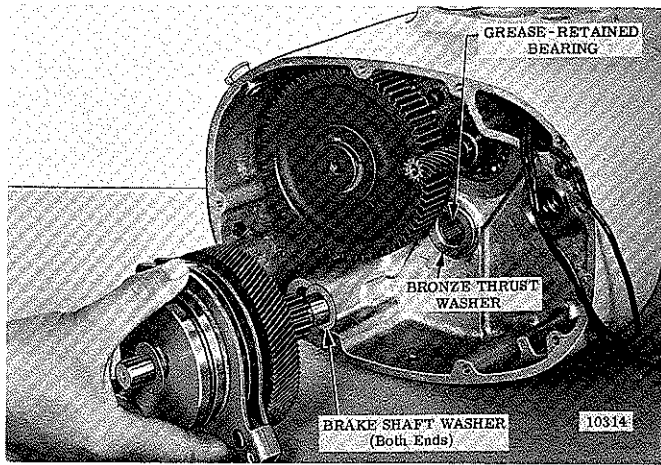

Figure 7-8. Removing Load Brake and Clutch Assembly (1/4 & 1/2 Ton Hoists)

(2) On 1, 2 and 3 ton hoists, pull load brake and clutch assembly and intermediate gear assembly, including the thrust washers for each unit, from hoist frame (fig. 7-9).

d. Removal of Motor Assembly.

(1) Place hoist frame on wood blocks to protect integral gear on motor shaft. Loosen four motor mounting bolts and lift motor assembly from frame (fig. 7-10). Guide motor leads through wire passage to avoid damage. Remove friction disc spring from splined brake hub on motor shaft.

(2) On single phase model hoists, motor brake parts are attached to motor shaft and will come off with motor. On three phase models, the brake parts are assembled to frame.

NOTE: Single phase motor brakes have 2 friction discs and 2 friction plates. The 2 discs and only one plate are assembled on motor; the remaining plate is loosely assembled over support pins inside hoist frame.

(3) On two speed hoists remove the motor brake (par. 7-2. g.) before removing the motor.

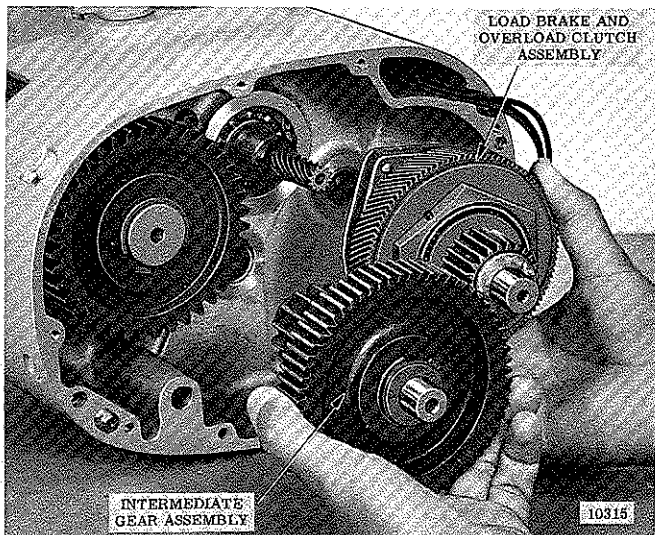

Figure 7-9. Removing Load Brake and Clutch and Intermediate Gear Subassemblies (1, 2 and 3 Ton Hoists)

e. Removal of Motor Brake. (Single Phase, Magnetic Type).

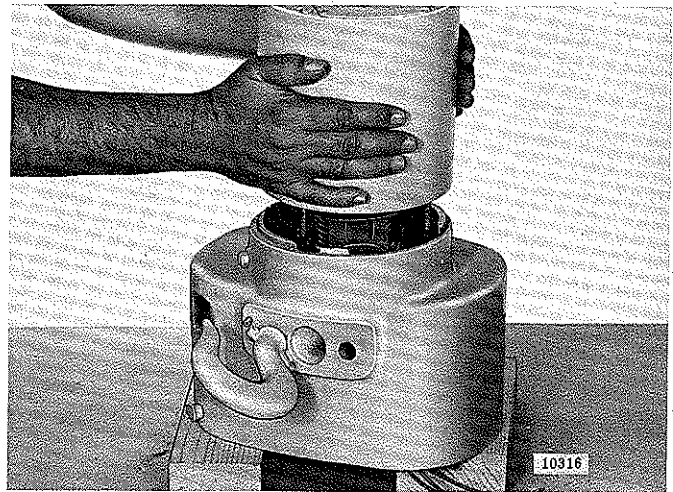

Figure 7-10. Removing Motor Assembly

(1) The type brake used on single phase push button model hoists is attached to motor shaft and is removed with motor (par. d., above).

(2) Brake friction plates, friction discs and friction disc spring can be lifted from motor after removing retaining ring and washer from motor shaft.

(3) The brake plunger and plunger spring are held in place by the splined hub which is keyed and pressed onto motor shaft. These parts should not be removed unless replacement is necessary. Refer to par. 7-9 for rebuild instructions.

f. Removal of Motor Brake. (Three Phase, Magnetic Type)

(1) Remove two self-locking nuts (fig. 7-11) securing brake spring cage to brake plate support pins and lift out assembled spring cage plunger, spring and compression plate (fig. 7-12). This assembly should not be further disassembled and is to be replaced only as an assembly.

IMPORTANT: Before removing plunger assembly, mark its position on support pins in frame so it can be reinstalled in its original position. **DO NOT** rotate 180° out of position on support pins. Replace plunger assembly if indentations on edge of plunger, caused by striking stator laminations, exceed .005".

(2) Lift out two friction discs and one friction plate. Do not remove plate support pins unless replacement is necessary.

g. Removal of Motor Brake. (Two Speed Hoists).

(1) Remove brake housing screws, housing, support plate screws, support plate assembly, friction disc, and stationary discs.

(2) Remove endplate screws and endplate.

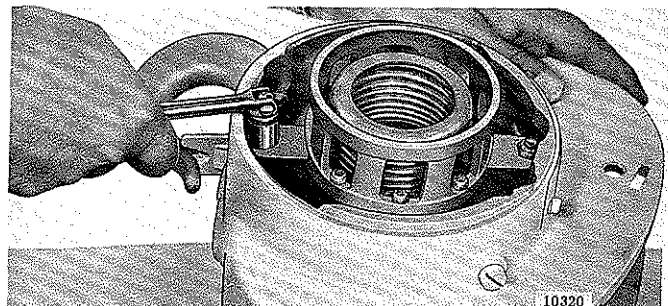

Figure 7-11. Removing Self-locking Nuts Securing Spring Plunger to Brake Plate Pins



Figure 7-13. Pulling Sprocket Gear from Sprocket Shaft Using Common Puller

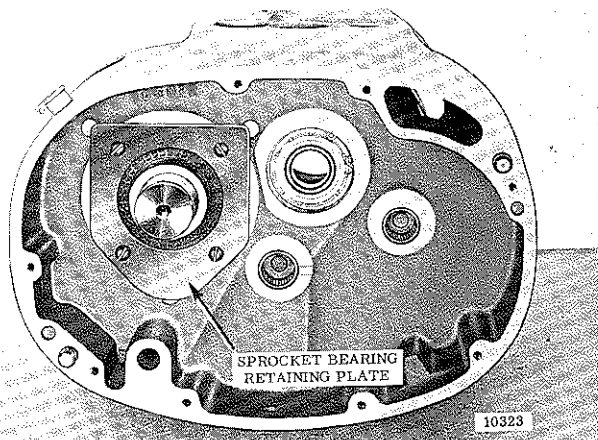

Figure 7-14. View of Sprocket Bearing Retaining Plate

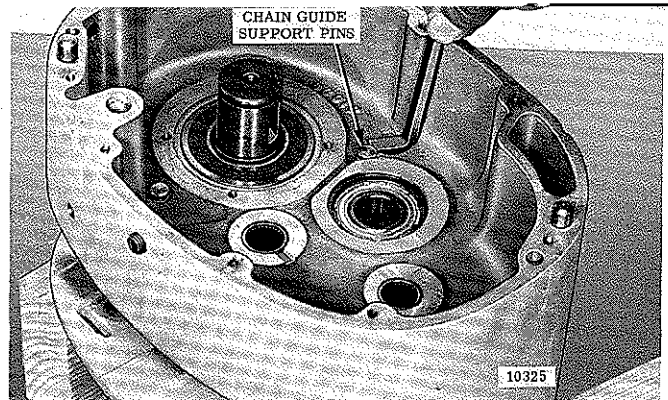

Figure 7-16. Removing Chain Guide Support Pins Using Pry Bar.

(4) Remove sprocket shaft and front ball bearing assembly from frame by lifting up on end of shaft while prying up on sprocket as illustrated in figure 7-17. The chain guide will need to be repositioned in frame as sprocket shaft is raised to allow the sprocket to pass thru hole of guide (fig. 7-18). On roller chain model hoists, the chain stripper must be partly removed from guide by prying it out using screw driver or other suitable tool. See figures 7-19 and 7-20.

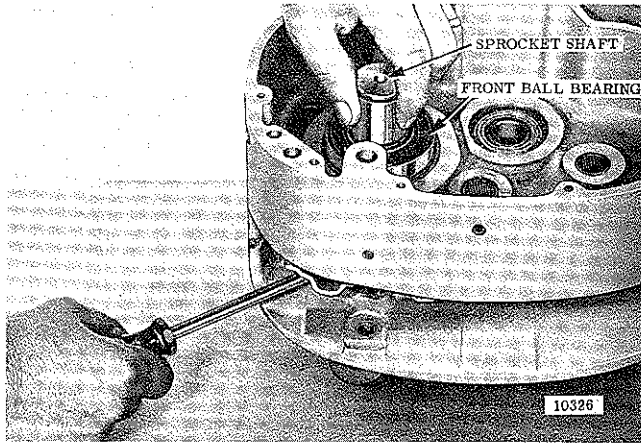

Figure 7-17. Removing Sprocket Shaft and Front Bearing

NOTE: Do not remove oil seal, ball bearings, and needle bearings from their bores in the frame unless they show evidence of wear or damage and require replacement. When replacing rear sprocket ball bearing pack bearing 1/2 full with NLGI No. 2 grease.

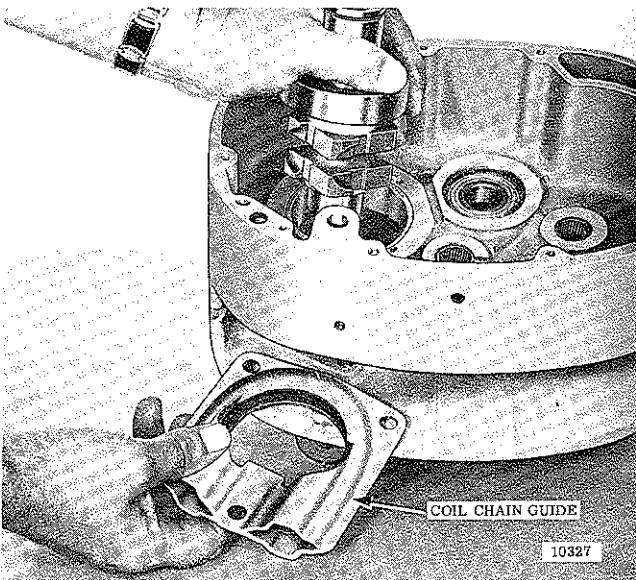

Figure 7-18. Chain Guide Being Removed From Frame as Sprocket Shaft is Lifted Out (Coil Chain Models)

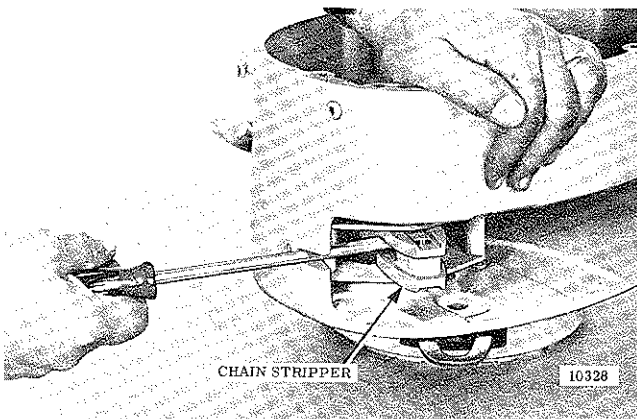

Figure 7-19. Chain Stripper Being Partly Removed From Chain Guide (Roller Chain Model)

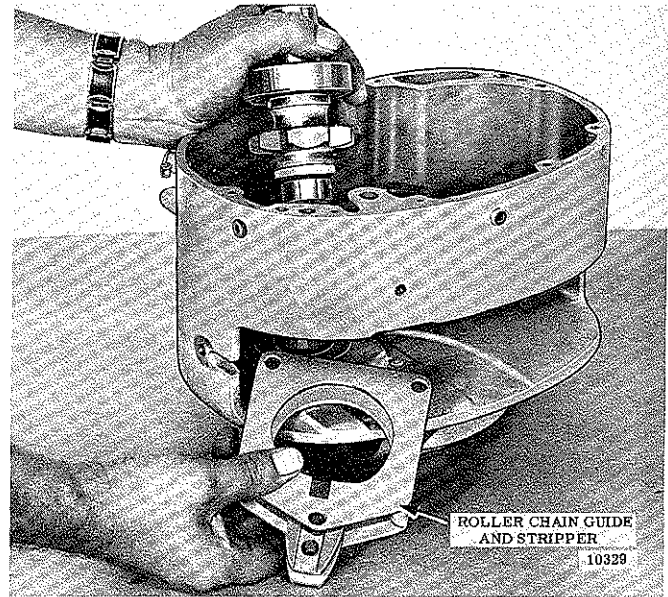

Figure 7-20. Chain Guide and Stripper Being Removed From Frame as Sprocket Shaft is Lifted Out (Roller Chain Model)

b. Disassembly of Upper Hook. (Hook Suspension Models.)

(1) On 1/4 thru 1 ton models, drive pin from hook nut using drift punch and unscrew upper hook. Nut is reached thru access hole in side of hoist frame. See figure 7-21.

(2) On 2 ton models, unscrew two hex socket head screws holding suspension bushing lock assembly to upper block (fig. 7-22) and remove lock. Unscrew suspension bushing from block to remove hook. To disassemble block from frame remove drive pin from nut inside frame and unscrew nut from stud holding body to frame. Remove drive pin securing threaded end of chain anchor in block and unscrew anchor. Block can then be lifted off.

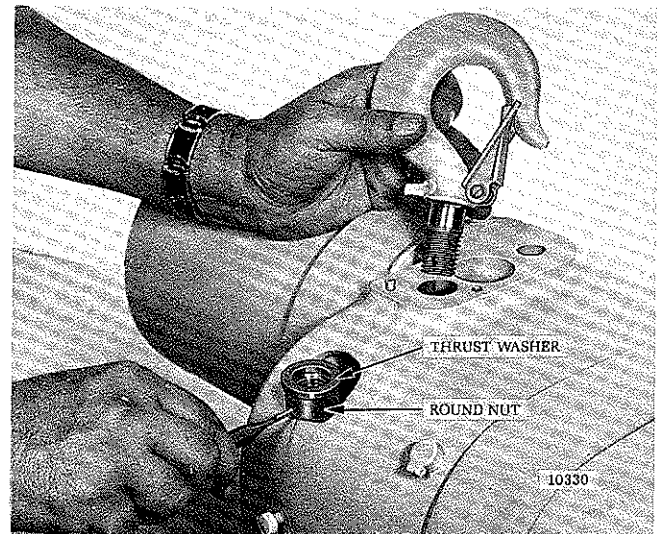

Figure 7-21. Removing Upper Hook and Hook Nut From Hoist Frame (1/4 thru 1 ton models)

NOTE: Hook and bushing assembly is not to be further disassembled as nut securing bushing to hook shank is welded in place at the factory. Only the assembly is available for replacement.

(3) On 3 ton models, remove retaining ring from connecting rod pin and push connecting rod pin through bracket and connecting rod, releasing hanger (see figure 7-2). Raise hanger above hoist frame to provide access to hook nut. Rotate hook until grooved pin in nut is visible from end of hanger frame. Using a drift punch, drive grooved pin thru hook nut until it hits hanger pocket. Remove drift far enough to hold nut from turning and unscrew hook from nut. Thrust washer will fall free.

(4) To remove connecting rod (figure 7-2) on 3 ton hoist drive pin from rod nut using drift punch and unscrew connecting rod. Nut is reached thru access hole in side of hoist frame. (See figure 7-21).

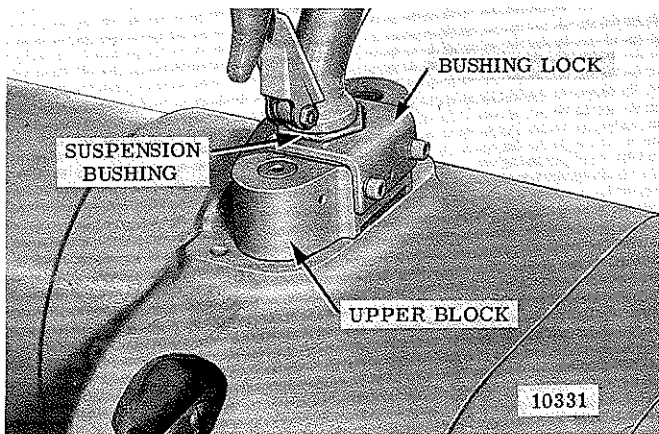

Figure 7-22. View of Upper Hook Assembled To Hoist Frame (2 Ton Models)

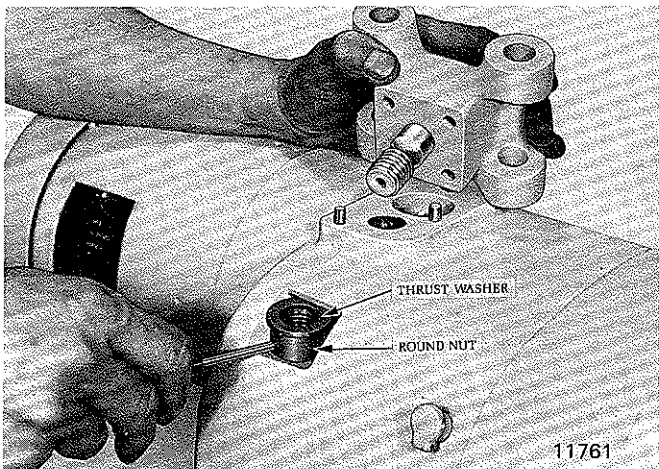

Figure 7-23. Removing Suspension Lug (1/4 Thru 1 Ton Model)

c. Disassembly of Suspension Lug (Lug Suspension Models).

(1) On 1/4 thru 1 ton models drive grooved pin from the round nut inside the hoist frame. Hold round nut from rotating with drift punch thru access hole in side of hoist frame. Unscrew suspension stud assembly by wrenching hex on top of suspension lug (see figure 7-23).

(2) On 2 ton models, remove three hex socket head screws securing the two lock plates to block at top of frame and pull out locks. Remove suspension lug, using an extra thin 1-1/4" open end wrench to unscrew suspension bushing from block. Instructions for removing block from frame are given in paragraph b., (2).

NOTE: The suspension lug is not to be further disassembled, as nut securing suspension bolt and bushing to lug is permanently secured in place at the factory. Only the suspension lug assembly is available for replacement.

(3) On 3 ton models lug bolt is removed in same manner as hook. See paragraph 7-3, b, (3).

d. Reassembly.

(1) Before assembly, all parts should be thoroughly cleaned and inspected to determine their serviceability. Replace parts that are excessively worn or damaged.

(2) Reassemble suspension hook or lug, chain guide, sprocket shaft and sprocket gear to frame following a reverse procedure of the disassembly steps listed in paragraphs (a.) thru (c.), above. If ball bearing is to be reinstalled on sprocket be certain to position it so that the seal side of bearing faces out, away from sprocket. To help prevent oil seepage, apply sealant on O.D. of sprocket bearing and in seat for the ring gasket.

7-4. REBUILD OF LOAD BRAKE AND OVERLOAD CLUTCH ASSEMBLY.

a. Disassembly.

(1) Place load brake and clutch assembly, flange up, in a vise equipped with brass or copper jaw plates to protect pinion gear teeth. Remove snap ring from end of load brake shaft (fig. 7-24).

(2) Using a puller tool, remove brake flange from shaft. A groove is provided around outer diameter for this purpose. See figure 7-25. Remove key from shaft and lift off 2 friction discs, and the pawl and ratchet assembly (fig. 7-26).

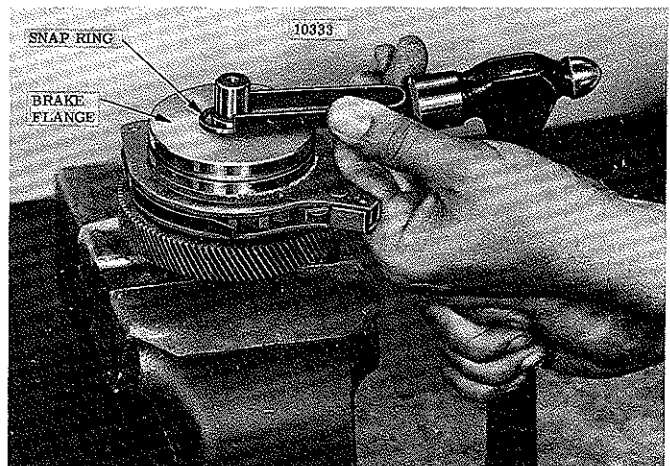

Figure 7-24. Removing Snap Ring from Load Brake Shaft

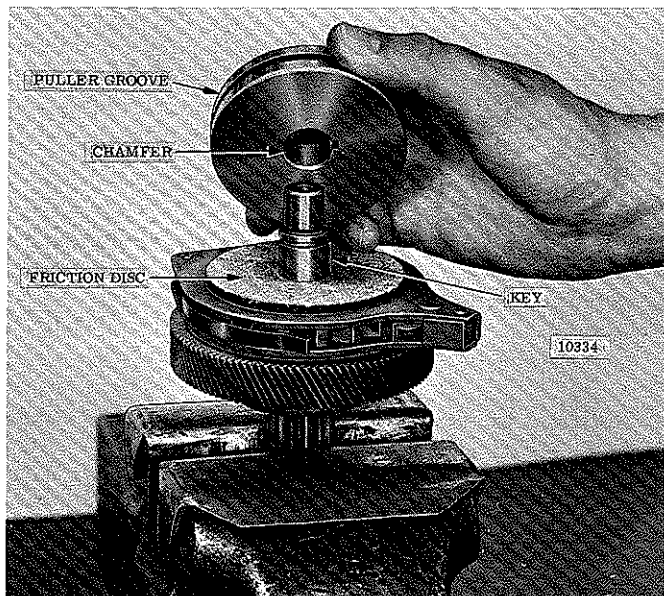

Figure 7-25. View Showing Load Brake Flange Removed

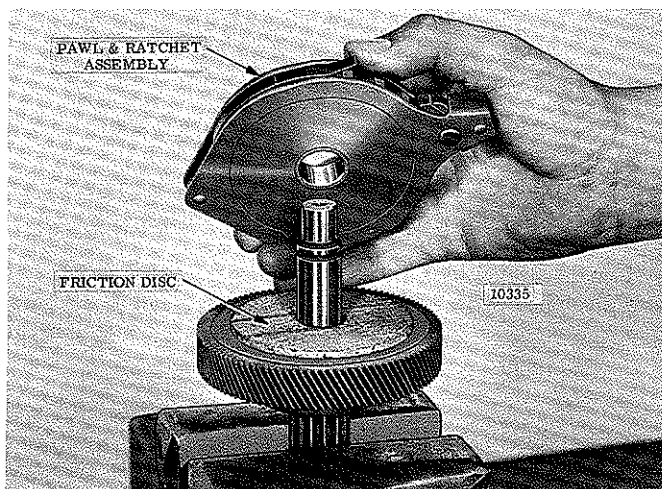

Figure 7-26. Removing Pawl and Ratchet Assembly From Load Brake Shaft

(3) Remove load brake gear and overload clutch assembly from output pinion shaft. Pull the spring from its recess in clutch cone (fig. 7-27) but do not further disassemble gear and clutch assembly. see "NOTE" below.

NOTE: Disassembly of the load brake gear and overload clutch assembly (fig. 7-27) is not recommended. Clutch pressure is preset by the factory at assembly to provide the correct torque to allow the clutch to refuse loads within a specified range (110% of rated load to 180% rated load). It is suggested whenever there is a need to repair or readjust the gear and clutch assembly that it be sent to an authorized **BUDGIT** Hoist Repair Station where adequate tools, fixtures and appropriate test equipment is available.

(4) The load brake pawl and ratchet is a riveted assembly and is not to be disassembled.

b. Reassembly.

(1) Before assembly, all parts should be cleaned and inspected to determine their serviceability. Replace parts that are excessively worn or damaged.

(2) Reassemble load brake parts following a reverse procedure of the disassembly steps listed above, observing the assembly steps (3) thru (6) below.

(3) Before installing spring in its recess in center of clutch cone (fig. 7-27) apply a good grade of ball bearing grease to inside of recess. Spring must be positioned exactly as illustrated, butted against pin.

(4) When installing pawl and ratchet assembly on load brake shaft, be certain that teeth on ratchet face are in the same direction as shown in fig. 7-26. The ratchet assembly should rotate freely when turned counter-clockwise and the pawl should engage ratchet teeth when unit is turned clockwise.

(5) When installing brake flange position it with chamfer facing friction disc, fig. 7-25.

(6) The brake spring must be pre-loaded at assembly to a torque of from 6 to 10 lb. ft. when used with yellow (color code) spring and a torque of 10 to 14 lb. ft. when used with plain (no color code) spring. (See Section IX for proper spring). This is accomplished using a plumber's strap wrench to wind (rotate) load brake gear to set up spring (fig. 7-28) while pressing brake flange into place using an arbor press. Clamp pinion end of shaft into a portable vise to keep brake from rotating in press. Use brass or copper jaw plates on vise to protect pinion gear teeth. Wind gear counter-clockwise (viewing brake from flange end) with strap wrench and press down on flange until snap ring groove in shaft is exposed allowing snap ring to be installed. Use extreme care not to over wind spring as yield will result and final spring torque will be reduced. Do not wind gear beyond point necessary to install snap ring in groove.

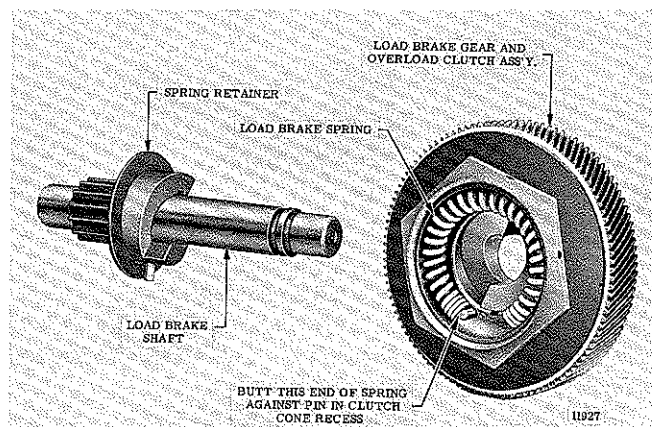

Figure 7-27. Load Brake Gear and Overload Clutch Assembly Removed from Load Brake Shaft Showing Brake Spring Installed in Clutch Cone

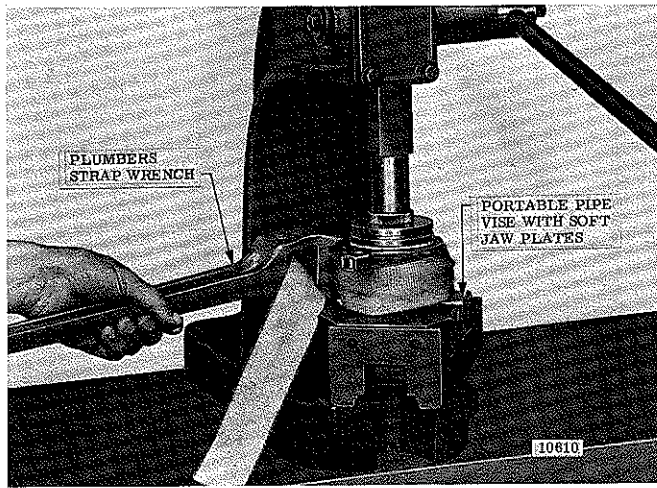

Figure 7-28. Winding Load Brake Gear Using a Strap Wrench to Set Up Load Brake Spring.

7-5. REBUILD OF LOWER BLOCK AND LOAD CHAIN ASSEMBLY.

a. Disassembly (1/4 through 1-ton, single reeved models).

(1) Separate load chain (coil or roller type) from lower block assembly. Drive out small roll pin securing lower block pin in lower block yoke and push lower block pin from yoke to release chain. On roller chain models, an adapter is used to attach chain to lower block. This adapter is removed from end of chain by first driving out small roll pin and then pushing out adapter pin.

(2) Drive grooved pin from limit actuator and pull actuator from end of chain.

(3) Lower blocks are of a pinned construction, permitting replacement of body, thrust bearing, or hook and nut assembly. To disassemble, drive spring pin from hook nut (Fig. 7-29). With pin removed, hold hook nut from turning with drift punch and rotate hook to unscrew it from nut.

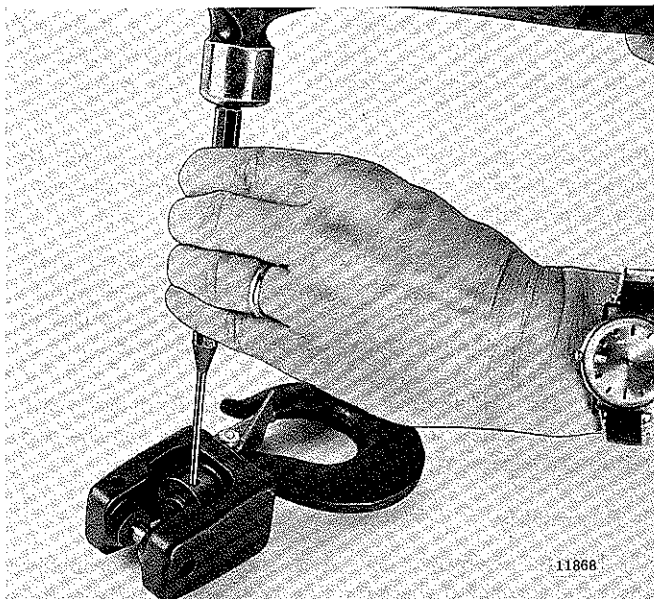

Figure 7-29. Removing Roll Pin Securing Hook Nut to Hook Shank

Separate hook, bearing shield, needle bearing and two thrust washers from body. Hook and nut are drilled at assembly and are replaced only as an assembly.

b. Disassembly (2-ton, double reeved models).

(1) On 2-ton roller chain models, remove retaining ring from one end of sprocket pin and press pin from lower block body. Grasp chain and pull out sprocket and two spring washers from body. Do not remove needle bearing from sprocket or pressure lube fitting from sprocket pin unless replacement is necessary.

(2) On 2-ton coil chain models, remove fillister head screw securing center guide in top of lower block body and lift out guide (Fig. 7-30) and sprocket pin lock (Fig. 7-31). Press sprocket pin from body and pull out chain, sprocket and washer (Fig. 7-32). Do not remove bushing type bearing from sprocket or pressure lube fitting from sprocket pin unless replacement is necessary.

(3) On early models, the hook nuts are welded in place by the factory. Do not attempt further disassembly of these lower block assemblies. Only complete lower block assemblies or body and hook assemblies are available for replacement.

(4) On later models (identified by a hole in the side of the block below the capacity marking), lower hooks may be removed. To disassemble, drive groove pin from hook nut with drift punch. With pin removed, hold hook nut from turning with drift punch and rotate hook to unscrew it from nut. Separate hook, nut, bearing shield, needle bearing and two thrust washers from body. Hook and nut are drilled at assembly and are replaced only as an assembly.

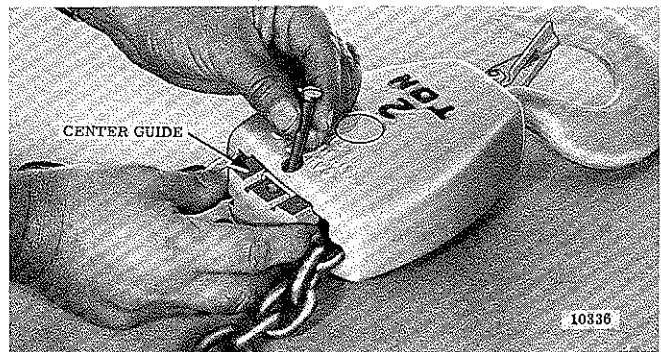

Figure 7-30. Removing Chain Center Guide from 2 and 3 Ton Lower Block Assembly (Coil Chain Model)

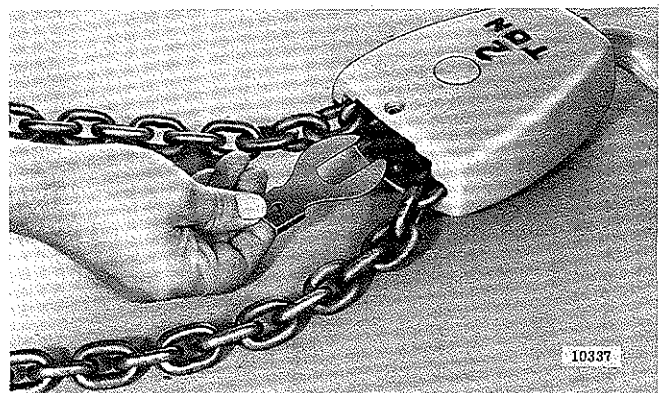

Figure 7-31. Removing Sprocket Pin Lock On 2 and 3 Ton Lower Block Assembly (Coil Chain Model)



Figure 7-32. Removing Coil Chain and Sprocket on 2 and 3 Ton Lower Block Assembly (Coil Chain Model)

c. Disassembly (3-ton, triple reeved models).

(1) Remove chain sprocket from lower block following procedure for 2-ton coil chain models described in paragraph 7-5, b, (2) above.

(2) To disconnect end of chain anchored to lower block, remove retaining ring from pin bore (Fig. 7-33). Push connecting link pin from bore by pressing through hole provided in opposite side of block (Fig. 7-34). Chain connecting link is now free and can be further disassembled for inspection.

(3) To remove hook from lower block body, first drive grooved pin from hook nut. Then hold nut from turning using drift punch and rotate hook to unscrew it from nut. Separate hook, shroud and thrust washer from body. Note that bearing surface of washer faces nut.

(4) To remove chain sprocket from upper suspension hanger, first remove hanger as outlined in paragraph 7-2, a, (4). With hanger removed, push sprocket pin from hanger and sprocket. Note: Sprocket pin must be removed toward side having small anti-rotation pin slot in hanger.

d. Reassembly of Lower Blocks.

(1) Clean, inspect and replace worn or damaged parts.

(2) Lubricate and reassemble following a reverse procedure of the disassembly steps above.

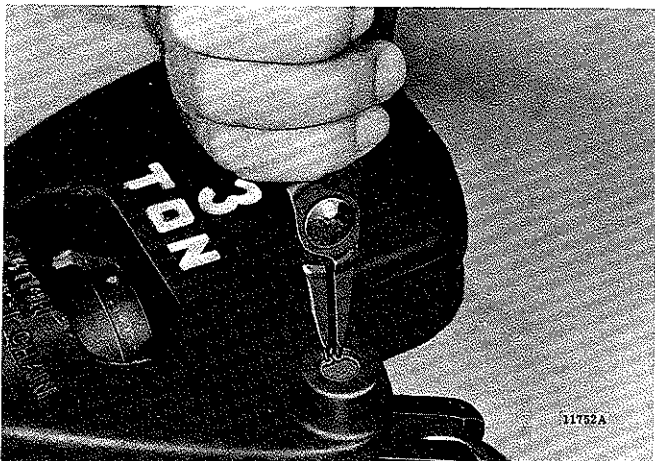

Figure 7-33. Removing Retaining Ring From Bore of Connecting Link Pin - 3 Ton Lower Block Assembly.

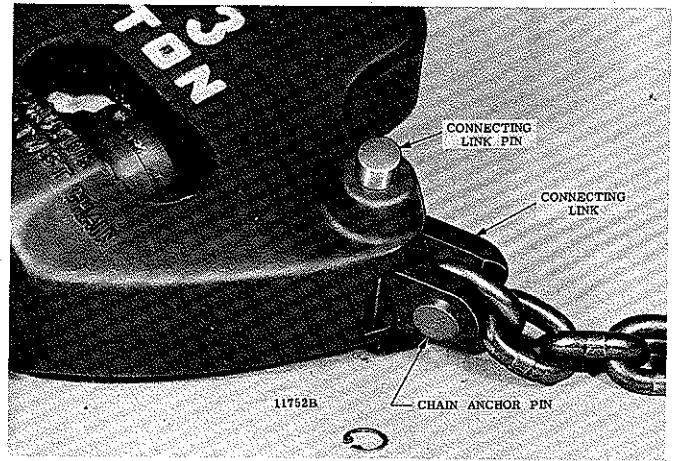

Figure 7-34. Removing Connecting Link Pin From 3 Ton Lower Block Assembly.

7-6. REBUILD OF ELECTRICAL CONTROLS AND GEAR CASE COVER SUBASSEMBLY.

a. Disassembly.

(1) Disconnect two limit switch leads from contactor. Also, if hoist has a transformer, disconnect transformer leads at the contactor or terminal board.

(2) Remove reconnectable terminal board if so equipped.

(3) Remove two screws and lift transformer from gear case cover if hoist is so equipped.

(4) Remove two screws and lockwashers attaching contactor assembly to cover and lift off contactor. Refer to paragraph 7-8 for instructions for rebuild of contactor assembly.

(5) Remove two hex socket head screws and lockwashers securing limit switch assembly to gear case cover and pull limit switch assembly and control shaft from cover. Remove flanged sleeve bearing from shaft, or bore if it remains in cover.

(6) Loosen two nuts and screws holding limit switch to its retainer bracket and pull four spacers from between switch plates and bracket.

(7) Remove self-locking nut from end of control shaft and pull off washer, switch assembly, slide arm assembly, two spacer washers, drive spacer, insulation strip, centering lever, spring, spacer tube, retainer bracket and washer.

NOTE: Do not remove needle bearings from gear case cover unless they show evidence of wear or damage and require replacement.

b. Reassembly.

(1) Before assembly, all parts should be thoroughly cleaned and inspected to determine their serviceability. Replace parts that are worn or damaged.

(2) Reassemble parts to gear case cover in reverse of the

disassembly steps above. Ends of centering spring must straddle centering levers. Lubricate contact segments of limit switch with small amount of graphite grease. Be certain when installing limit switch that board with blue lead wire faces out.

7-7. REBUILD OF PUSH BUTTON STATION AND CONDUCTOR CABLE ASSEMBLY.

a. Disassembly.

(1) Remove two fillister head screws from front of push button station and one screw from back. Lift off rear half of body.

(2) Loosen three terminal screws, detach conductor cable leads and remove cable assembly.

(3) Remove six round head machine screws and lift off three stationary contacts. Also lift out two interlock bars and their retainers.

(4) Remove both push buttons, springs, movable contacts and contact springs by unscrewing shoulder screws.

b. Reassembly.

(1) Before assembly, all parts should be thoroughly cleaned and inspected to determine their serviceability. Replace all parts that are worn or damaged.

(2) Reassemble push button station and conductor cable following a reverse procedure of the disassembly steps listed above. When installing wave washer type springs, position them with concave side toward movable contacts. Cone shaped wire springs are installed with large diameter toward movable contact. Also be sure they fit over shoulder of screw. When installing rear body screw, be certain the loop in end of strain reliever is engaged by the screw.

NOTE: Do not attempt to shorten or lengthen push button conductor cable. Odd length conductor cable assemblies for other than standard 10 ft. lift hoists can be procured from the factory.

7-8. REBUILD OF CONTACTOR ASSEMBLY.

a. **General.** Wear or damage to contactor parts requires replacement of complete contactor assembly.

7-9. REBUILD OF SINGLE PHASE MOTOR ASSEMBLY.

a. Disassembly.

(1) To inspect capacitor, remove two cover mounting screws and lift off capacitor cover. Do not disconnect wires at capacitor unless capacitor must be replaced.

(2) Remove two screws and lift motor shaft cover from end bell.

(3) Remove four motor mounting bolts.

(4) Remove external retaining ring from end of shaft and press shaft out of bearing in end bell using an arbor press.

(5) Remove motor end bell from stator assembly. If necessary loosen it by tapping with soft mallet. Be careful, if

tapping from inside, that stationary switch is not damaged.

(6) Remove four screws and separate stationary switch from end bell.

(7) If stationary switch assembly is defective and requires replacement, remove it by unsoldering three wire leads from stator winding.

(8) Remove internal retaining ring from bearing bore in end bell and press out bearing assembly.

(9) Do not remove centrifugal switch assembly from rotor shaft unless replacement is necessary.

(10) Remove brake hub from motor shaft using a gear puller or by inserting two (2) steel bars through slots in plunger and pressing hub off with an arbor press. Protect gear end of shaft with soft metal when applying pressure.

b. Reassembly.

(1) Before assembly, all parts should be cleaned and inspected to determine their serviceability. Replace all parts that are worn or damaged.

(2) Reassemble motor following a reverse procedure of the disassembly steps listed above.

(3) Plunger-to-shaft fit should be lubricated with a dry lubricant.

(4) If the centrifugal switch assembly was removed from the rotor shaft during disassembly, install a new switch. Be sure it is completely seated against shoulder on shaft.

(5) If wiring to stationary switch was disconnected, reconnect it in accordance with applicable wiring diagram in Section VIII.

(6) After reinstalling hoist motor, connect hoist to power supply and carefully complete both checks (a) and (b) below:

(a.) To check direction of rotation, briefly operate "UP" button. If hook lowers, interchange motor lead "T1" with "T4" at the contactor or controller. Hook must raise when the "UP" push button is operated.

(b.) To check the starting winding switch, connect ammeter (minimum 10 ampere) to motor lead "T5". Amperes must drop to zero in approximately one second when operating hoist in both "UP" and "DOWN" directions. If ampere reading does not drop to zero, interchange motor leads "T7" and "T8". If, after above checks were made with motor having been run in both directions, the ammeter reading still does not return to zero, the motor switch is not functioning properly and should be replaced.

WARNING

Do not change control circuit wiring. Severe damage and malfunction of hoist may result.

7-10. REBUILD OF THREE PHASE MOTOR ASSEMBLY.

a. Disassembly.

(1) If motor is equipped with a fan (2½ H.P. motors and Extra Heavy Duty Hoist motors), remove three self tapping screws securing fan shroud to end bell and lift off shroud. Then, remove external retaining ring from end of motor shaft and pull off fan.

(2) Pull four motor mounting bolts from motor and separate stator assembly from the end bell and rotor shaft assembly.

(3) On motors not equipped with fan, remove two screws and lift motor shaft cover from end bell.

(4) Remove external retaining ring from end of motor shaft and press shaft from bearing in end bell.

(5) Remove internal retaining ring from bearing bore in end bell and press out bearing assembly.

(6) Do not remove brake hub unless replacement is necessary. Hub teeth that show indentations from brake discs indicate hub should be replaced. To replace hub remove retaining ring and pull hub from shaft with a gear puller.

b. Reassembly.

(1) Before assembly, all parts should be cleaned and inspected to determine their serviceability. Replace all parts that are worn or damaged.

(2) Reassemble motor following a reverse procedure of the disassembly steps listed above.

7-11. REASSEMBLY OF HOIST FROM SUBASSEMBLIES.

a. **General.** The procedure to be followed to reassemble the hoist from subassemblies is in reverse order of the disassembly steps outlined in paragraph 7-2. Listed below are special assembly precautions which should be observed to assure proper assembly.

NOTE: Grease retained bearings (see Section VII, par. 7-2, c, (1) and fig. 7-8) have loose rollers. When reassembling hoist, make certain the correct number of rollers are held in roller cup with grease before assembling load brake shaft to hoist.

b. **Assembly of Load Brake Thrust Washers.** When reinstalling load brake assembly be certain thrust washers are properly installed at both ends of load brake shaft, as noted below.

(1) A bronze thrust washer with a lug on one side belongs on pinion end of shaft and must be installed so that its lug engages the special slot located on spotface surrounding bearing bore inside hoist frame or gearcase cover. Use heavy grease to hold washer in proper position in frame or cover (depending upon hoist capacity) during assembly.

(2) On hoists with Catalog Number prefix letters "A", "C", "D", "L" an 11/16" I.D. plain steel thrust washer must be used between end of pinion gear and the bronze thrust washer (fig. 7-8).

(3) A 5/8" I.D. steel thrust washer is to be installed on the brake flange end (end opposite pinion) of load brake assembly.

c. **Two Speed Hoist Motor Brake.** Instructions for adjusting brake are inside housing and are repeated below.

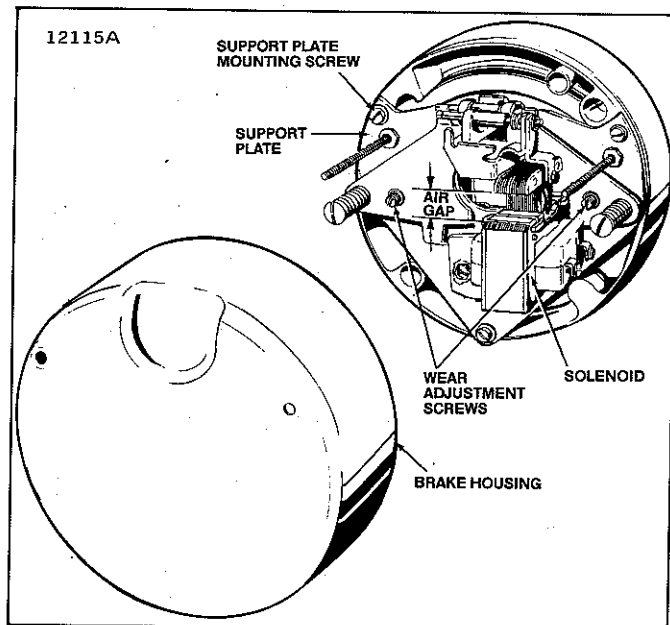

Figure 7-35. Two Speed Hoist Motor Brake.

(1) Remove housing.

(2) Turn both wear adjustment screws equal amounts, approximately 1/8 turn clockwise, until a solenoid air gap of 13/32 is attained.

(3) Replace housing.

d. Assembly of Load Chain.

NOTE: Coil chain must be installed so welds on vertical links face away from the load sprocket.

(1) On coil chain and roller chain models install load chain over sprocket before load brake assembly is installed. Insert anchor end of chain (end opposite lower block on single reeved models) into chain guide opening on far side of hoist (viewing frame from anchor screw side). Rotate sprocket gear by hand counter-clockwise as chain is fed into opening. When sufficient chain has been run into hoist to reach anchor position, plus a slack loop, install limit actuator on anchor end of load chain (see (3) below) and attach end of chain to frame with special fillister head screw. Be certain chain is not twisted.

(2) On roller chain models, the chain may be installed after steps (d) and (e) below are accomplished, allowing chain to be run into hoist under power. Caution must be exercised so that fingers or hands are not caught in chain while it is being fed into hoist.

NOTE: The spring clip connecting link must be attached to anchor end of roller load chain before chain is run into hoist. Failure to do so may result in damage to chain or hoist.

(3) When installing limit actuator on anchor end of load chain attach it at link shown below using a grooved pin. See Figure 3-2.

<u>TYPE CHAIN</u>	<u>SIZE CHAIN</u>	<u>NUMBER OF CHAIN LINKS FROM END LINK</u>
Coil	1/4" Wire Dia.	8 Links
Coil	5/16" Wire Dia.	8 Links
Roller	5/8" Pitch	8 Links
Roller	3/4" Pitch	7 Links

e. **Wiring Hook-Up.** Before installing hoist, connect wiring to electrical controls in accordance with applicable wiring diagram in Section VIII. Wires are coded and/or numbered to agree with wiring diagrams.

f. **Lubricate Hoist.** Lubricate hoist as outlined in Section IV.

7-12. TESTING HOIST.

a. **General.** After completion of reassembly and before placing hoist in service, hoist should be tested to insure safe operation. To test: suspend hoist from an overhead supporting member of sufficient strength to carry rated load; connect to a power supply of the specified voltage (see data plate attached to motor); and perform the following checks and adjustments.

b. **Check For Correct Control Operation.** Refer to Section II, par. 2-4, (d), under "Warning".

c. **Check Upper and Lower Limit Stop Operation.** To determine if upper and lower limit stop functions properly, make the following checks while operating hoist with push button control and actuating the limit lever by hand:

(1) Depress "UP" push button and with chain running in raise direction, pull down on end of limit lever at tail chain side of hoist (left side facing cover end). The "UP" limit switch should cut off power, causing the hoist to stop.

(2) Depress "DOWN" push button and with chain running in lowering direction, push up on same end of limit lever. The "DOWN" limit switch should cut off power, causing the hoist to stop.

(3) If hoist does not stop in both travel directions, check for improper wiring. Refer to par. 6-2 and appropriate wiring diagram. If wiring is correct, check to see that limit switch is correctly installed, par. 7-6, (b).

(4) As a final check, operate hoist (no load) in the lowering direction and allow tail chain limit actuator to trip limit lever. Hook should stop. Repeat check in hoisting direction and allow lower block to trip limit lever. Hook should stop.

d. **Check Hoist With Rated Load.** Attach rated load to lower hook and check hoist operation. If hoist does not lift rated load, refer to par. 7-13.

(1) Operate hoist to raise load. When control is released, hoist should instantaneously stop and hold load at that level.

(2) Operate hoist to lower load a short distance, then release control. Hoist should stop instantaneously and hold load at that level.

(3) If hoist does not stop or hold load refer to Section VI.

7-13. TEST PROCEDURE FOR CHECKING OPERATION OF MAN-GUARD OVERLOAD CLUTCH

a. **General.** The overload clutch must be tested using known weights. The following prerequisites (par. (1) thru (4)) must be strictly observed in performing this test.

(1) A qualified person shall determine before testing, that all structures supporting the hoist are adequately strong to withstand the test load of 200 percent of rated hoist load, whether hoist is tested in installed position or moved to a designated test facility.

(2) Loads used for testing must be accurately known.

(3) Test shall be made only by a qualified operator thoroughly familiar with the hoist and the purpose of the test.

(4) Provide adequate and proper rigging to insure test loads are securely attached, properly balanced, and will lift level.

b. **Test Procedure.** With the above prerequisites satisfied and hoist properly connected to electrical power, proceed with the test as follows:

(1) Using a known load equal to rated load of hoist, operate hoist to lift load. Raise load high enough to be certain the entire load is freely suspended. **Clutch should not slip at rated load.** If hoist does not lift rated load, clutch requires adjustment. Refer to Section V, par. 5-4, c.

(2) Increase load to 200 percent rated load and operate hoist to lift the load. **Clutch must slip,** causing the hoist to refuse to lift the load. If hoist lifts this overload, the overload clutch is out-of-adjustment and must be readjusted. Refer to Section V, par. 5-4, c.

(3) If clutch slips as required in step (2) above, continue to run hoist (clutch slipping - hoist refusing to lift load) for five (5) cycles of one (1) second each.

(4) Remove excess weight to return the load to rated hoist load. Lift rated load one final time to be certain that the clutch does not slip and that the hoist lifts the rated load.

WARNING

DO NOT LIFT MORE THAN RATED LOAD EXCEPT FOR TEST PURPOSES.

NOTICE

THIS EQUIPMENT MUST BE EFFECTIVELY GROUNDED ACCORDING TO THE NATIONAL ELECTRICAL CODE, ARTICLES 250-57, 250-59, OR 610-51 OR OTHER APPLICABLE CODES. IF THE GROUNDING METHOD USED IS THROUGH THE TROLLEY WHEELS, THEN EACH SECTION OF TRACK MUST BE GROUNDED BY METAL-TO-METAL CONNECTION TO THE BUILDING GROUND OR ELECTRICAL SYSTEM GROUND.

SECTION VIII - WIRING DIAGRAMS

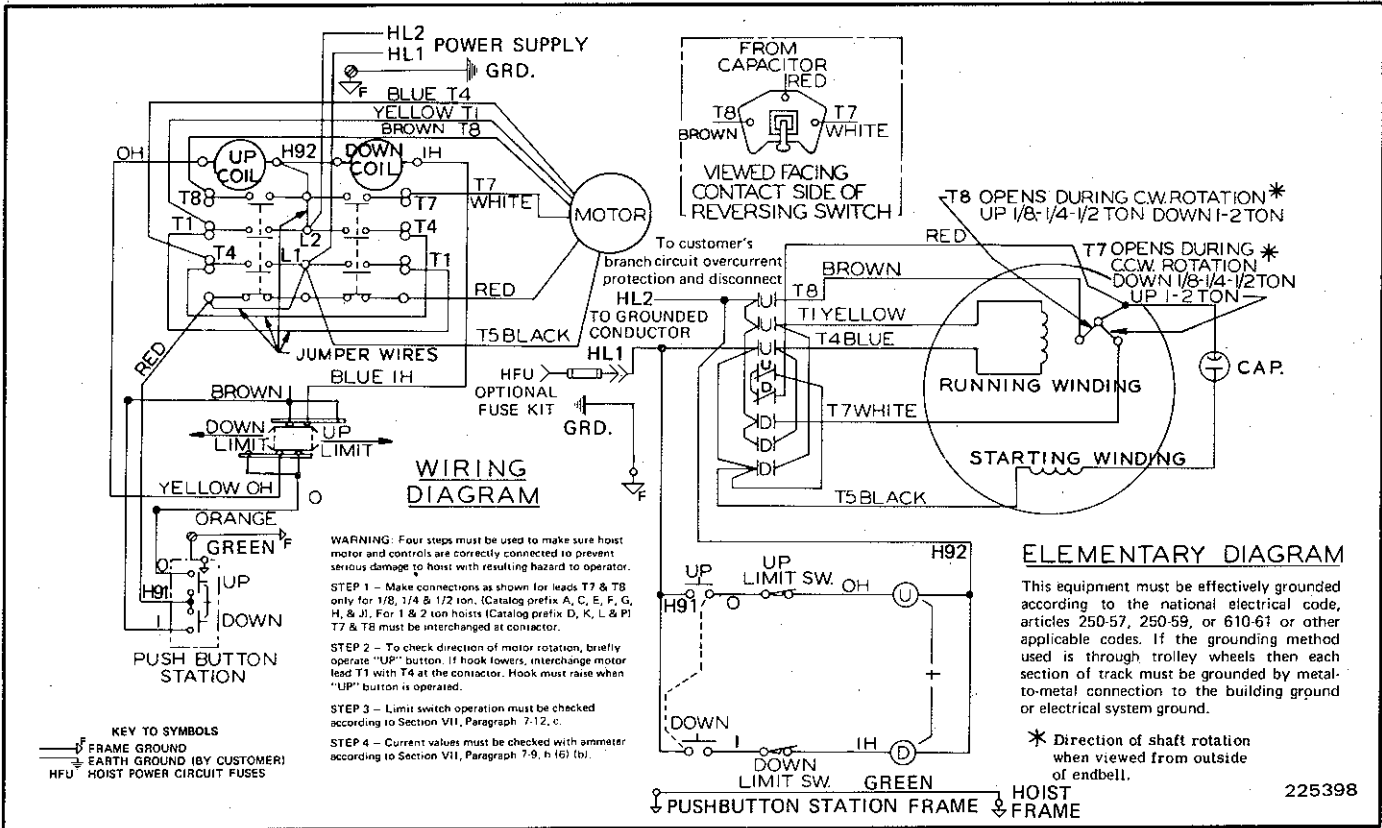

Figure 8-1. Electrical Diagrams for 115 Volt, 1-Phase, 60 Hertz, A.C. Hoists with Push Button Control and BH-2101 Contactor.

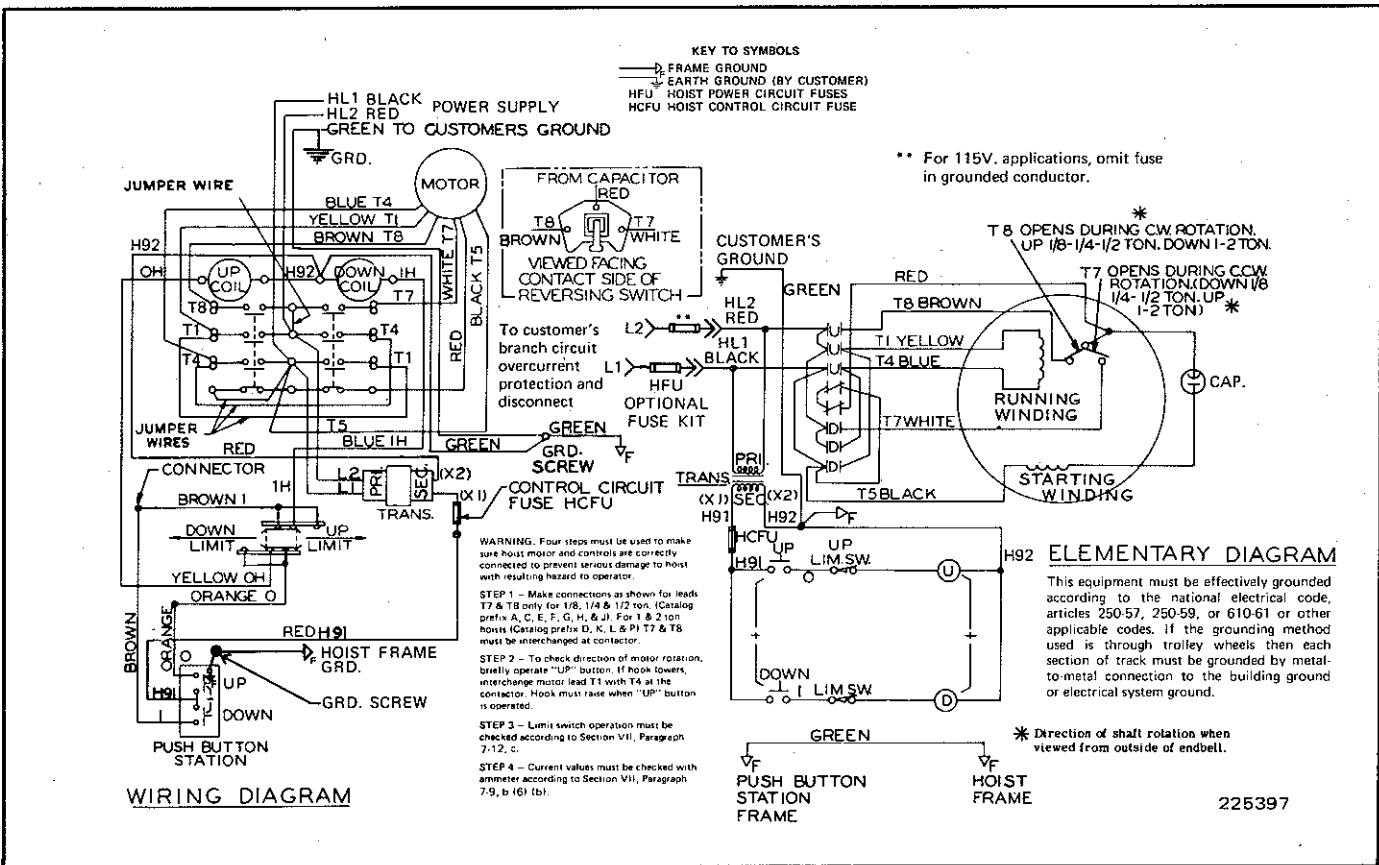

Figure 8-2. Electrical Diagrams for 230 Volt, 1-Phase, 60 Hertz, A.C. Hoists with Push Button Control and BH-2102 Contactor (Also for 115 Volt, 1-Phase Hoists with Special 24 Volt Control).

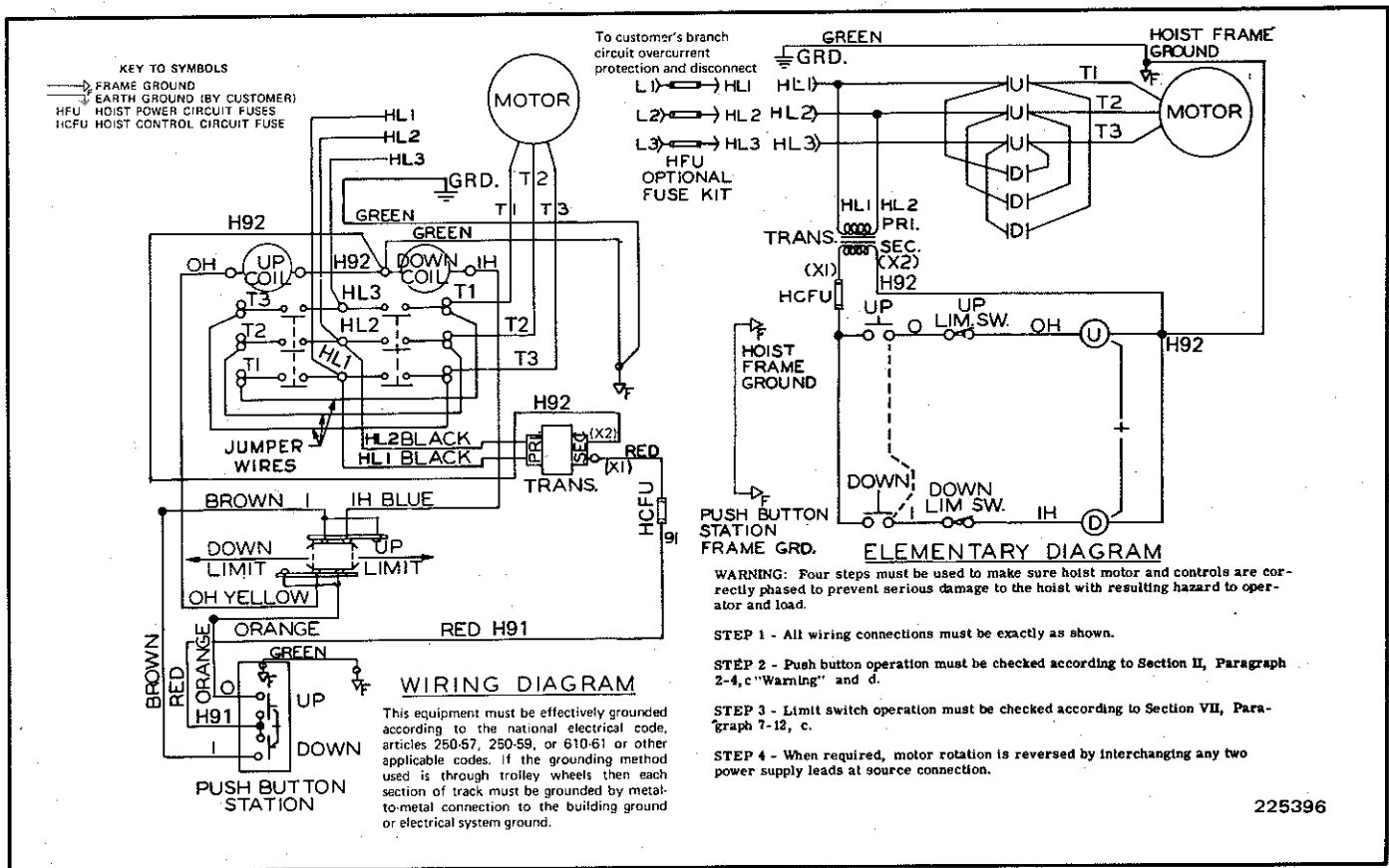

Figure 8-3. Electrical Diagrams for Single Voltage 208-230-460-575, 3 Phase, 60 Hertz, Single Speed A.C. Hoists with Push Button Control and BH-2103 Contractor.

NOTE: SEE FIGURE 8-4 ON FOLLOWING PAGE FOR WIRING DIAGRAM ON 230/460-3-60 RECONNECTABLE HOISTS WITH BH-2103 CONTACTOR.

NOTES

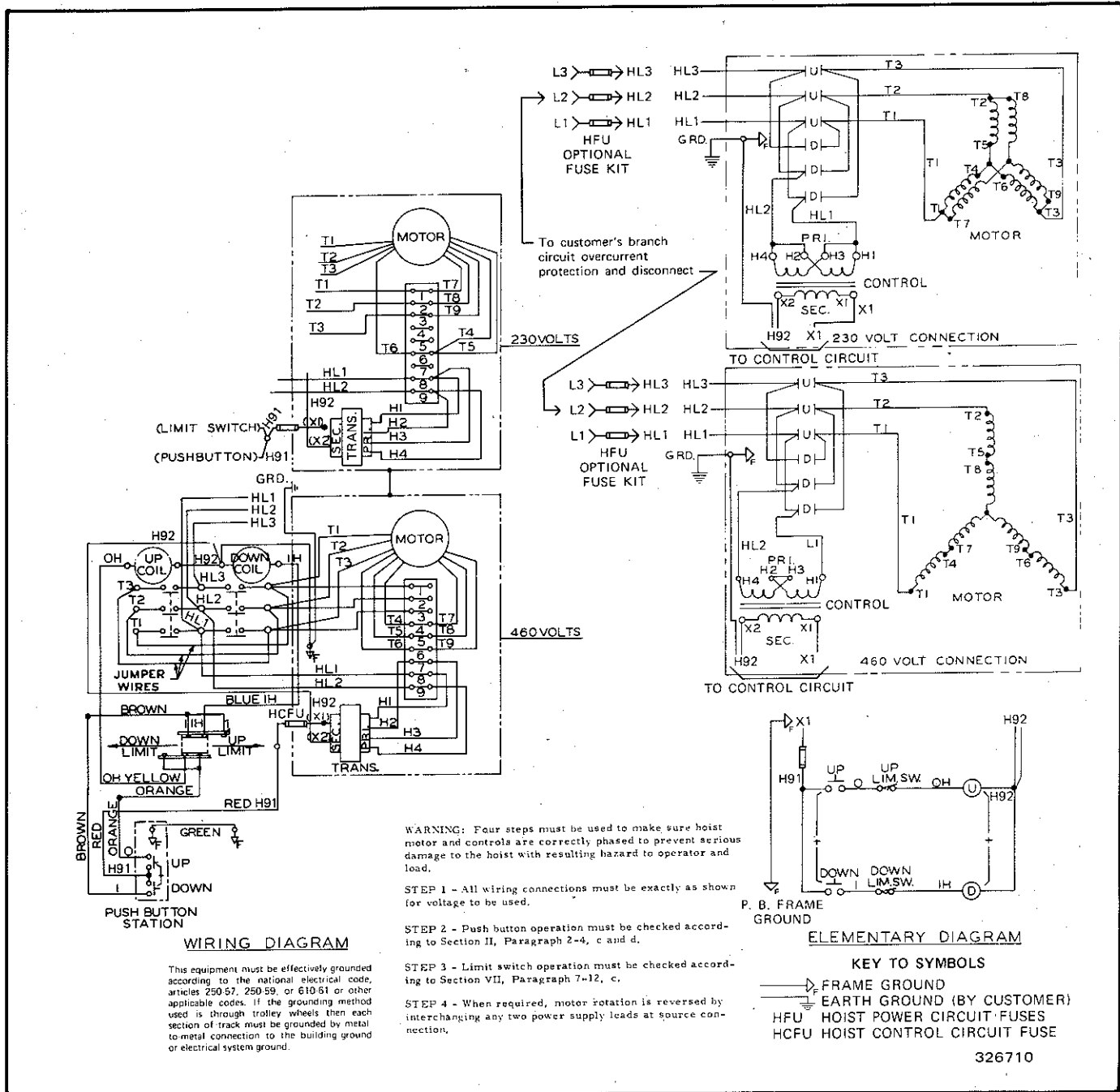

Figure 8-4. Electrical Diagrams for Reconnectable 230/460 Volt, 3 Phase, 60 Hertz, Single Speed A.C. Hoists with Push Button Control and BH-2103 contactor.

NOTICE

BUDGIT Electric Hoist motors are designed as an integral part of the hoist and should not be serviced in any way beyond the instructions contained in this manual. Complete wound stator winding data and machining information is available to Authorized Repair Stations only.

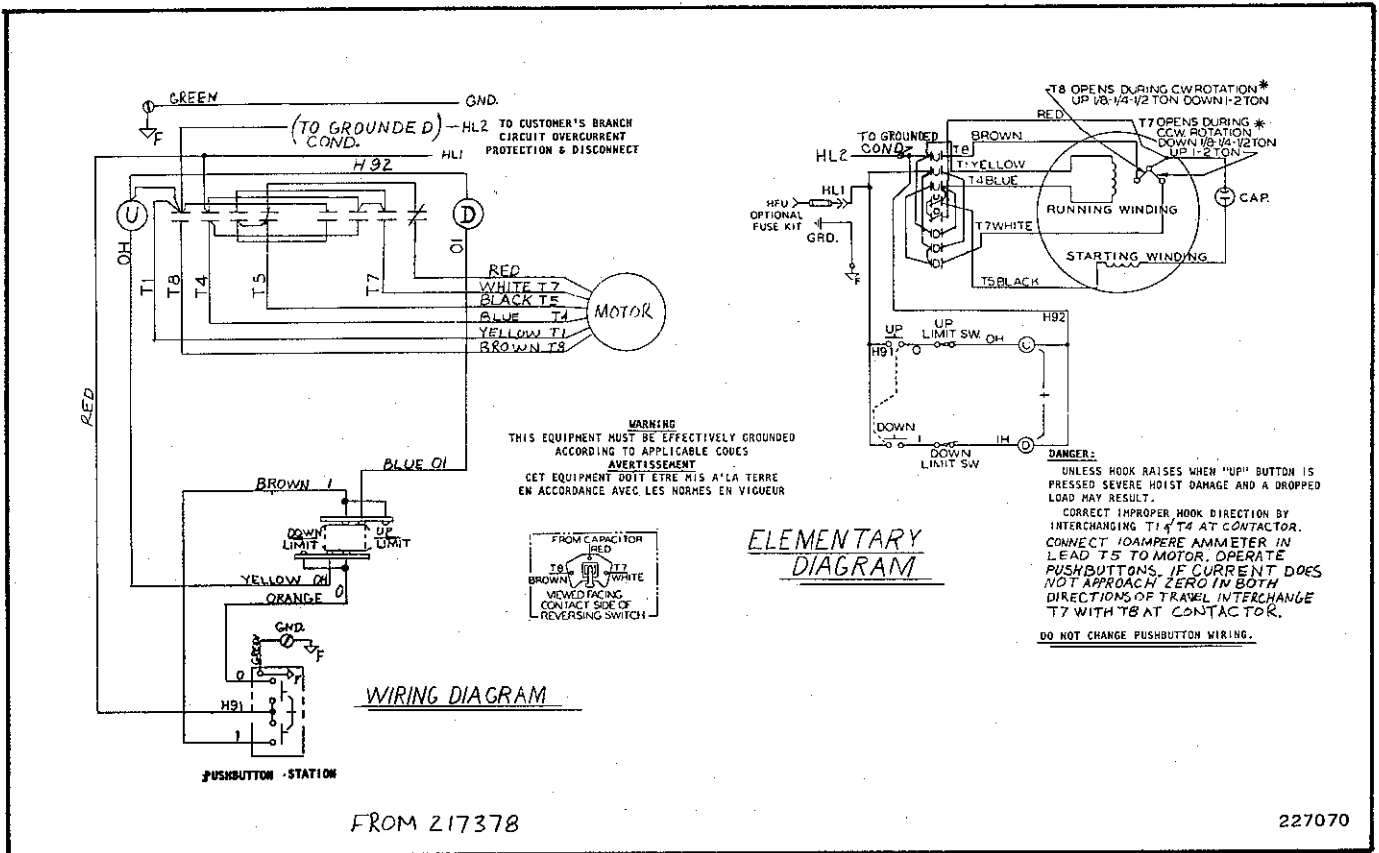

Figure 8-5. Electrical Diagrams for 115 Volt, 1-Phase, 60 Hertz, A.C. Hoists with Push Button Control and BH-2159 Contactor.

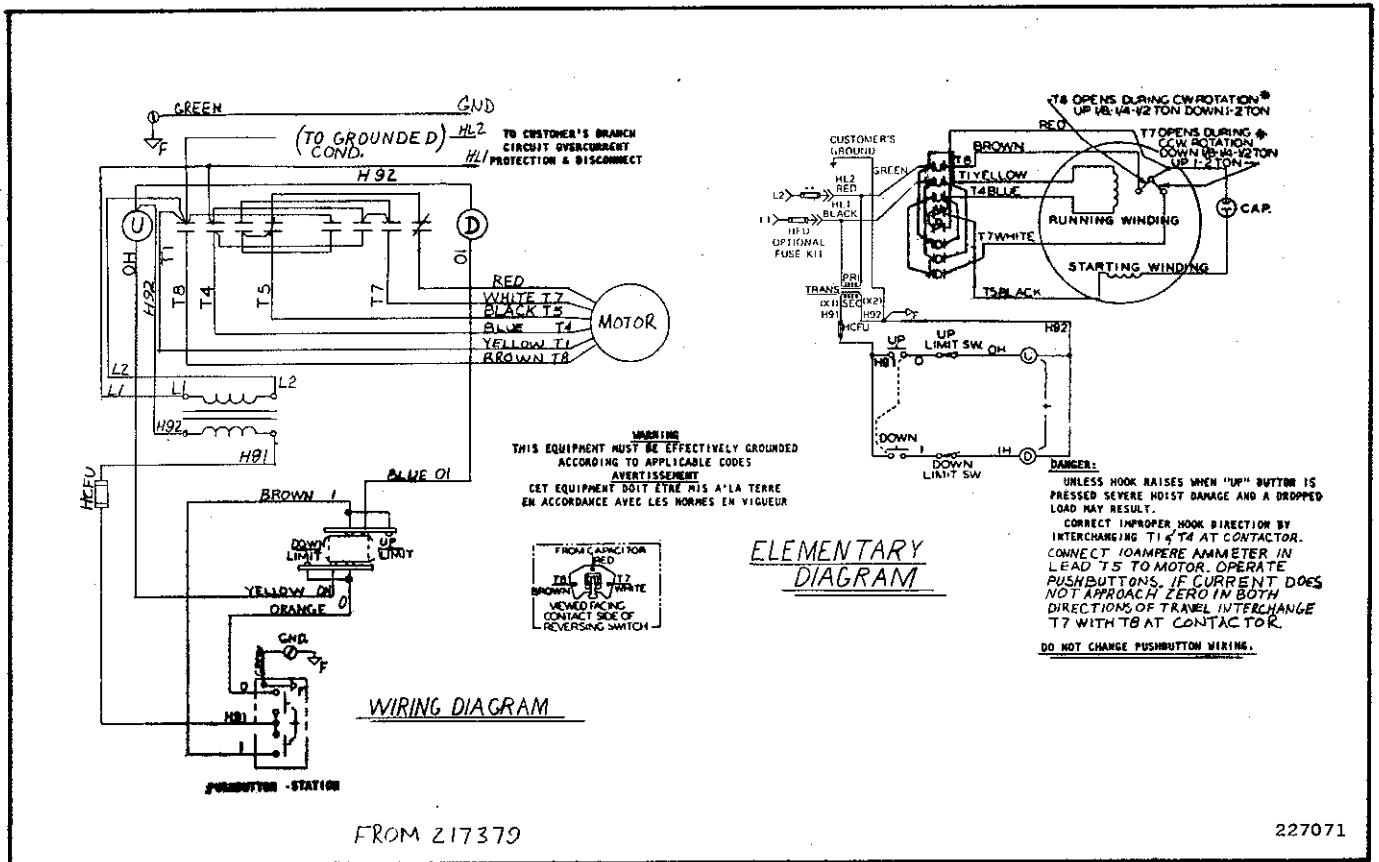

Figure 8-6. Electrical Diagrams for 230 Volt, 1-Phase, 60 Hertz, A.C. Hoists with Push Button Control and BH-2158 Contactor (Also for 115 Volt, 1-Phase Hoists with Special 24 Volt Control).

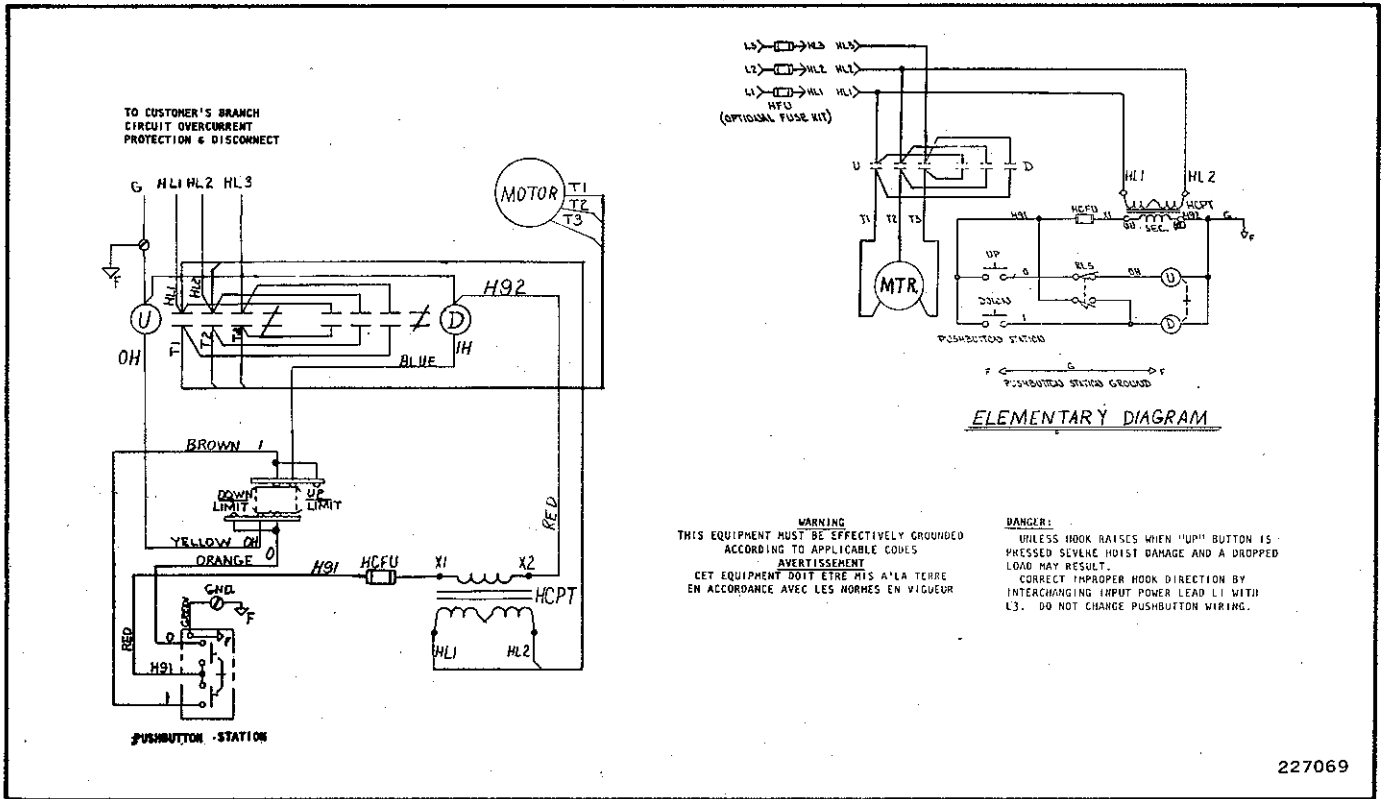

Figure 8-7. Electrical Diagrams for Single Voltage 208-230-460-575, 3 Phase, 60 Hertz, Single Speed A.C. Hoists with Push Button Control and BH-2156 Contactor.

NOTE: SEE FIGURE 8-8 ON FOLLOWING PAGE FOR WIRING DIAGRAM ON 230/460-3-60 RECONNECTABLE HOISTS WITH BH-2156 CONTACTOR.

NOTES

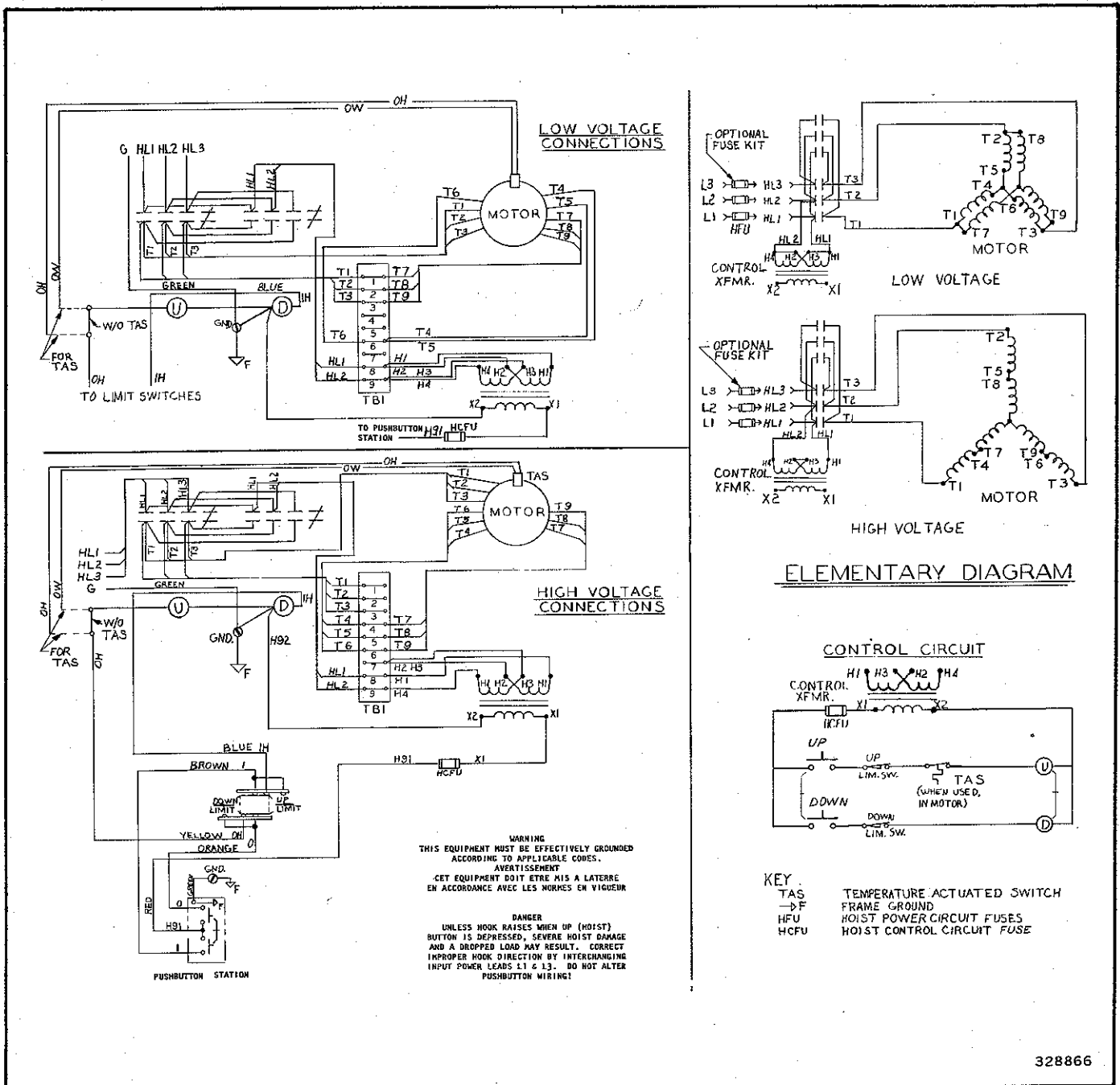
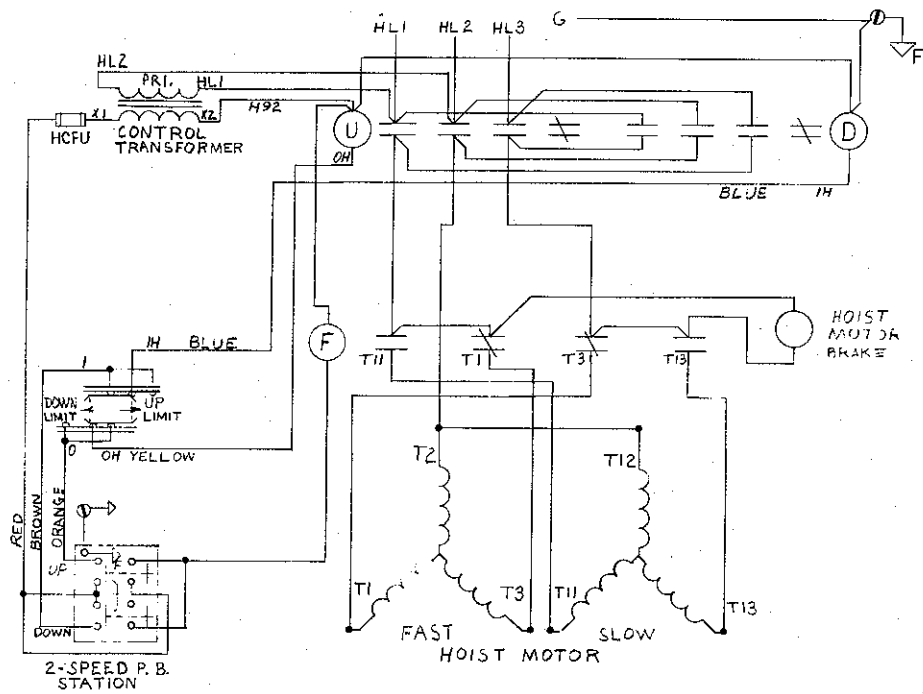

Figure 8-8. Electrical Diagrams for Reconnectable 230/460 Volt, 3 Phase, 60 Hertz, Single Speed A.C. Hoists with Push Button Control and BH-2156 Contactor.

NOTICE

BUDGIT Electric Hoist motors are designed as an integral part of the hoist and should not be serviced in any way beyond the instructions contained in this manual. Complete wound stator winding data and machining information is available to Authorized Repair Stations only.



DANGER
UNLESS HOOK RAISES WHEN UP (HOIST) BUTTON IS DEPRESSED, SEVERE HOIST DAMAGE AND A DROPPED LOAD MAY RESULT. CORRECT IMPROPER HOOK DIRECTION BY INTERCHANGING INPUT POWER LEADS L1 & L3. DO NOT ALTER PUSHBUTTON WIRING!

WARNING
THIS EQUIPMENT MUST BE EFFECTIVELY GROUNDED ACCORDING TO APPLICABLE CODES.
AVERTISSEMENT
CET EQUIPEMENT DOIT ETRE MIS A LA TERRE EN ACCORDANCE AVEC LES NORMES S1-N-VOLUEUP

TO CUSTOMER'S BRANCH
CIRCUIT OVERCURRENT
PROTECTION & DISCONNECT

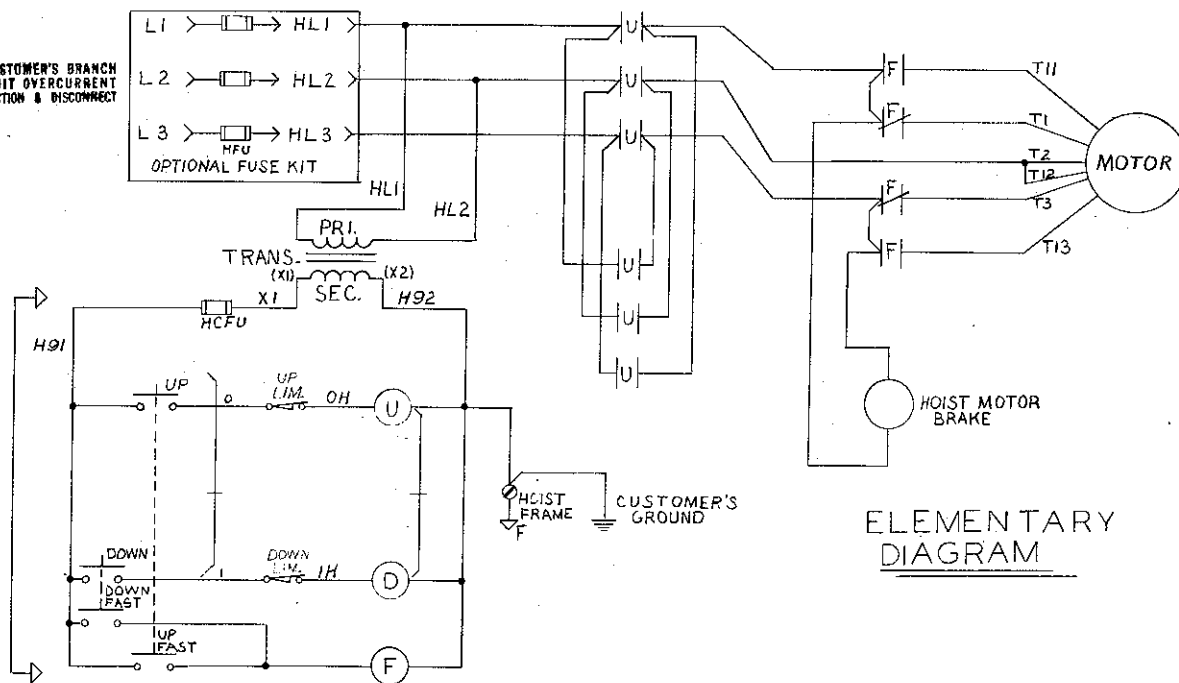

**ELEMENTARY
DIAGRAM**

329151

Figure 8-9. Electrical Diagrams for Single Voltage 208-230-460-575, 3 Phase, 60 Hertz, Two Speed A.C. Hoists with Push Button Control.

**Terminal Boards for Push Button
Hoists Showing Reconnectable Arrangements**

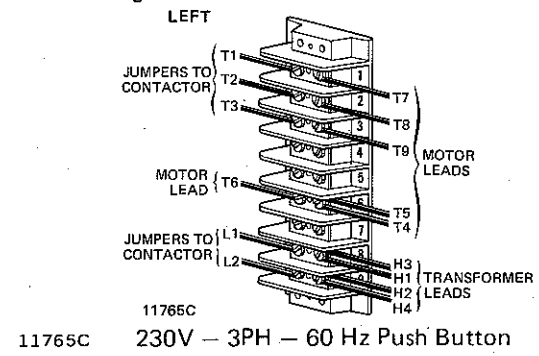
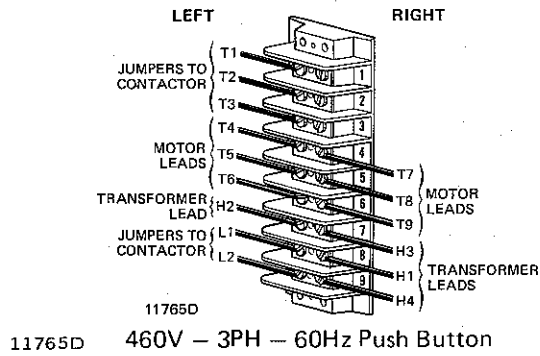

TO RECONNECT FROM 460 VOLTS TO 230 VOLTS:

- Move Lead T7 From Terminal 4-Right To 1-Right
- Move Lead T8 From Terminal 5-Right To 2-Right
- Move Lead T9 From Terminal 6-Right To 3-Right
- Move Lead T4 From Terminal 4-Left To 6-Right
- Move Lead T5 From Terminal 5-Left To 6-Right
- Move Lead H2 From Terminal 7-Left To 9-Right
- Move Lead H3 From Terminal 7-Right To 8-Right

TO RECONNECT FROM 230 VOLTS TO 460 VOLTS:

- Move Lead H3 From Terminal 8-Right To 7-Right
- Move Lead H2 From Terminal 9-Right To 7-Left
- Move Lead T5 From Terminal 6-Right To 5-Left
- Move Lead T4 From Terminal 6-Right To 4-Left
- Move Lead T9 From Terminal 3-Right To 6-Right
- Move Lead T8 From Terminal 2-Right To 5-Right
- Move Lead T7 From Terminal 1-Right To 4-Right

Figure 8-5. Terminal Board Connections For Reconnectable Dual Voltage 3 Phase Hoists
(Early model hoists have push-on contactors.)

SECTION IX - REPLACEMENT PARTS

This section contains complete replacement parts information for your new **BUDGIT** Electric Hoist. The parts are grouped and illustrated in exploded view photos to permit easy identification. Each part in an illustration is keyed by reference number to a corresponding parts table. In the table will be found the BH part number, description and quantity required.

When ordering replacement parts it will be necessary that you include, with your order, the BH part number of parts required, plus, hoist catalog number and model number, which will be found on the hoist nameplate attached to motor. For motors complete motor nameplate data is required. Complete inspection, maintenance and overhaul service is available for **BUDGIT** Electric Hoists at any of the

Authorized Repair Stations listed on the back cover: All are staffed by qualified factory-trained service men; have authorized testing equipment; and stock a complete inventory of genuine **BUDGIT** replacement parts.

NOTICE: Information herein is subject to change without notice. Parts must be ordered from an Authorized **BUDGIT** Repair Station or from a **BUDGIT** Hoist Distributor.

The numbers assigned to the parts of our various assemblies in our parts lists are not the part numbers used in manufacturing the part. They are identification numbers, that when given with the hoist serial number, permit us to identify, select or manufacture, and ship the correct part needed for any hoist.

INDEX OF EXPLODED VIEW PARTS ILLUSTRATIONS

Figure No.	Title	Page
9-1	Frame and External Parts	35-37
9-2	Upper Suspension, Load Chain and Lower Block Parts (2 Ton Hoists)	38-39
9-3	Upper Suspension, Load Chain and Lower Block Parts (3 Ton Hoists)	40-41
9-4	Gearing and Load Brake Parts (1/4 & 1/2 Ton Hoists)	42-43
9-5	Gearing and Load Brake Parts (1, 2 & 3 Ton Hoists)	44-45
9-6	Stator Operated Motor Brake Parts (3 Phase, Standard Model and Extra Heavy Duty Hoists)	46
9-6A	Solenoid Operated Motor Brake Parts (Two Speed Hoists Only)	47-48
9-7	Rotor Operated Motor Brake Parts (1 Phase, Standard Model Hoists)	49
9-8	Electrical Control Units (Early Model Hoists)	50-51
9-8A	Electrical Control Units (Late Model Hoists)	52-53
9-8B	Electrical Control Units (Two Speed Hoists Only)	54-55
9-9	Limit Lever and Switch Parts (Early Model Hoists)	56
9-9A	Limit Lever and Switch Parts (Late Model Hoists)	57
9-10	Push Button Station and Conductor Cable Assembly (Standard Models)	58-59
9-10A	Push Button Station and Conductor Cable Assembly (Two Speed Hoists Only)	60-61
9-11	Push Button Station and Conductor Cable Assembly (Extra Heavy Duty Models)	62
9-12	2 and 3 Ton Lower Block Assembly (Coil Chain Models Hoists)	63
9-13	2 Ton Lower Block Assembly (Roller Chain Models Hoists)	64
9-14	Single Phase Motor Assemblies	65
9-15	Three Phase Motor Assemblies - Single Speed	66
9-16	Replacement Motor Chart (Standard Model Hoists) - Single Speed	67
9-17	Replacement Motor Chart (Extra Heavy Duty Model Hoists)	67
9-18	Three Phase Motor Assembly - Two Speed	68-69

To enable us to expedite your parts order, always give Model and Catalog Number and Electric Current of Hoist. (See nameplate.)

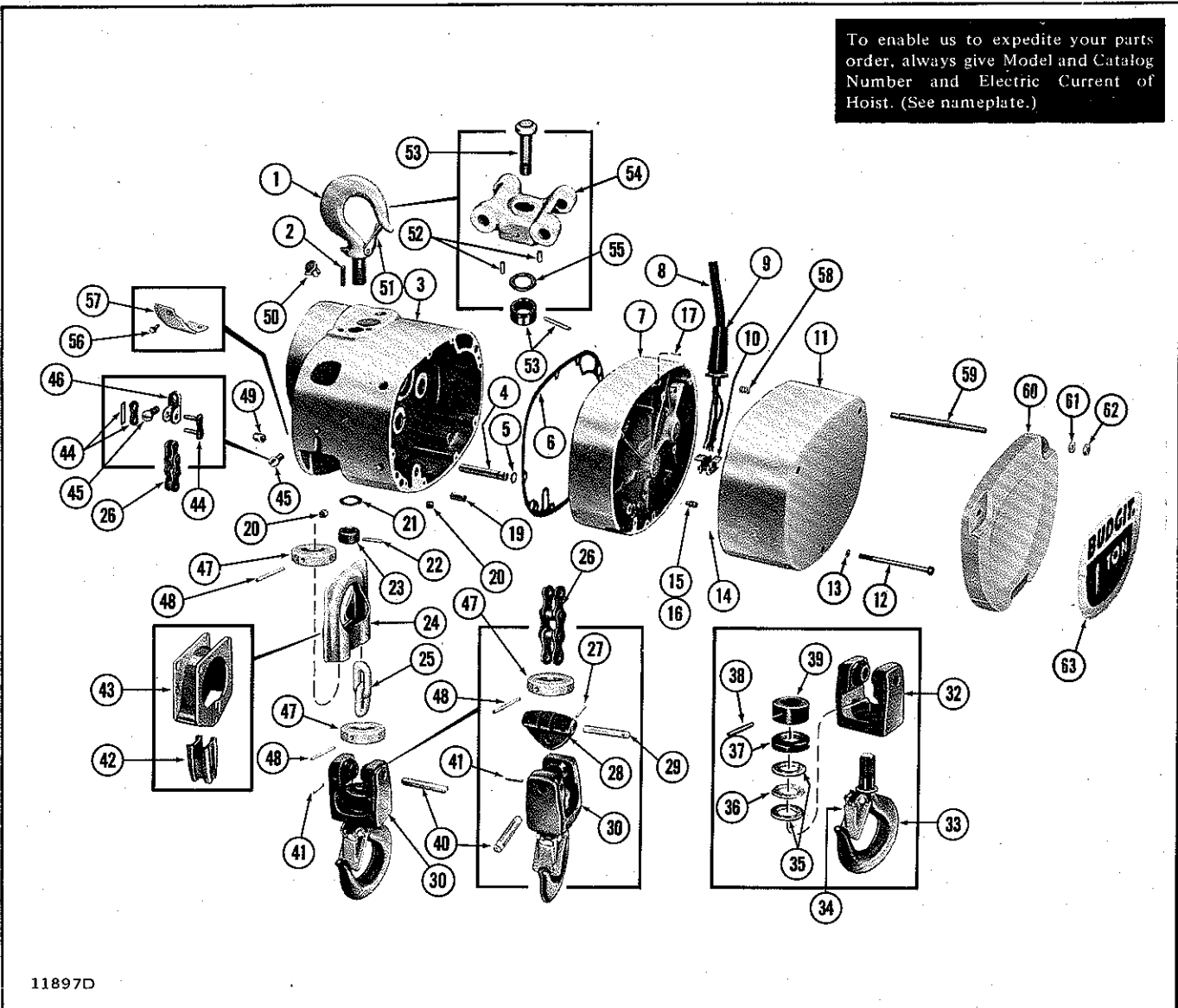

11897D

Figure 9-1. FRAME AND EXTERNAL PARTS
Standard & Extra Heavy Duty Hoists
(Except 2 & 3 Ton Model Upper Suspension, Load Chain & Lower Block)

Ref. No.	Part Number	Description	Qty. Req'd.
1	BH-1001	Hook Assembly – Upper with Latch (Includes Items 21, 22, 23 & 51)	1*
2	BH-1002	Pin – Stop, upper hook	1
3	BH-1003	Frame Assembly (For Hoists with Cat. No. prefix letters A, C, G, H & J. Includes 2 bushings, 1 needle bearing, 1 cup, 1 oil seal, 1 oil filler, 2 pipe plugs, and 2 dowel pins.)	1
	BH-1004	Frame Assembly (For Hoists with Cat. No. prefix letters D, K, L, P, M, S, & T. Includes 2 bushings, 2 needle bearings, 1 oil seal, 1 oil filler, 2 pipe plugs, and 2 dowel pins.)	1
	BH-1081	Frame Assembly (For ¼ & ½ ton capacity Extra Heavy Duty with suffix -4, -5). Includes sealed frame, 2 bushings, 1 needle bearing, 2 oil seals, 1 oil filler, 2 pipe plugs, and 2 dowel pins.	1
	BH-1094	Frame Assembly (For 1 & 2 ton Capacity Extra Heavy Duty with suffix -4, -5). Includes sealed frame, 2 bushings, 2 needle bearings, 2 oil seals, 1 oil filler, 2 pipe plugs, and 2 dowel pins.	1
	BH-1156	Frame Assembly (For Two Speed Hoists)	1
4	BH-1005	Pin – Support, chain guide	2
5	BH-1006	Gasket – "O" Ring	4
6	BH-1007	Gasket – Gearcase	1

(Continued on following page.)

Figure 9-1. FRAME AND EXTERNAL PARTS – Continued

Ref. No.	Part Number	Description	Qty. Req'd.
7	BH-1008	Cover Assembly – Gearcase (For Hoists with Cat. No. prefix letters A, C, G, H & J. Includes 1 needle bearing, 1 cup and 2 grooved pins).	1
	BH-1009	Cover Assembly – Gearcase (For Hoists with Cat. No. prefix letters D, K, L, P, M, S & T. Includes 2 needle bearings and 2 grooved pins).	1
	BH-1082	Cover Assembly – Gearcase (For ¼ & ½ Ton Extra Heavy Duty Hoists with suffix (-4, -5). Sealed and includes 1 needle bearing, 1 cup and 2 grooved pins.)	1
	BH-1095	Cover Assembly – Gearcase (For 1 & 2 ton Extra Heavy Duty Hoists with suffix (-4, -5). Sealed and includes 2 needle bearings and 2 grooved pins.	1
	BH-1157	Cover Assembly - Gearcase (For Two Speed Hoists)	1
8	BH-1010	Cable Assembly – Flexible, 5' (Incl. Items 9 & 10)	1
	BH-1011	(115 volt, 1 phase, 60 hertz hoists)	1
	BH-1012	(230 volt, 1 phase, 60 hertz hoists)	1
	BH-1013	(208/230/460/575 volt, 3 phase, 60 hertz hoists)	1
9	BH-1096	Grommet – Flexible Cable – 3 phase	1
	BH-1014	Grommet – Flexible Cable – 1 phase	1
10		Clamp – Flexible Cable	
11	BH-1016	Cover – Electrical Compartment	1
	BH-1017	(1/4 ton)	1
	BH-1018	(1/2 ton)	1
	BH-1019	(1 ton)	1
	BH-1085	(2 ton)	1
	BH-1020	(3 ton)	3
12	BH-1021	Screw – Fillister Head Machine	3
13	BH-1022	Lockwasher – Spring Type	3
14	BH-1023	Ring – Retaining	8
15	BH-1024	Lockwasher – Spring Type	8
16	BH-1025	Screw – Hex Socket Head	2
17	BH-1026	Pin – Grooved	1
18	BH-1027	Grommet – (Motor Driven Trolley Models) – Not Shown	2
19	BH-1028	Pin – Dowel, gearcase cover	2
20	BH-1029	Plug – Pipe, hex socket, 1/8"	1
21	BH-1030	Washer – Thrust, upper hook	1
22	**	Pin – Drive	1
23		Nut – Upper Hook	
24	BH-1031	Guide Assembly – Coil Load Chain	1
	BH-1032	(1/4 & 1/2 ton Hoists)	1
25	**	(1, 2 & 3 ton Hoists)	
	BH-1033	Chain Assembly – Coil, load	1
	BH-1034	(1/4" Dia. – 1/4 & 1/2 ton Hoists)	1*
	BH-1080	(5/16" Dia. – 1 ton Hoists)	1
	BH-1086	(1/4" Dia. – 1/4 & 1/2 ton Extra Heavy Duty Hoists – Zinc Plate)	1
26	***	(5/16" Dia. – 1 ton Extra Heavy Duty Hoist – Zinc Plate)	
	BH-1039	Chain Assembly – Roller, load	1
	BH-1040	(5/8" Pitch – For 1/4, and 1/2 ton hoists)	1*
	BH-1075	(3/4" Pitch – For 1 ton hoists)	1
	BH-1076	Repair Link – 5/8" Pitch Roller Chain (not shown)	1
	BH-1171	Repair Link – 3/4" Pitch Roller Chain (not shown)	1
27		Pin – Spring Drive	
28	BH-1172	Adapter Kit – Roller Load Chain (Incl. Items 27, 28, 29, 40 and 41)	1
	BH-1173	(5/8" Pitch – For 1/4, and 1/2 ton hoists)	1*
	BH-1043	(3/4" Pitch – For 1 ton hoists)	1
29	BH-1044	Pin – Adapter, roller load chain (5/8" Pitch)	1*
		Pin – Adapter, roller load chain (3/4" Pitch)	
30	BH-1035	Block Assembly – Lower, coil and roller chain (Incl. items 32 thru 39)	1
	BH-1035A	(For 1/4 ton hoists)	1
	BH-1036	(For 1/2 ton hoists)	1*
		(For 1 ton hoists)	
		Note: Lower block assemblies do not include attaching pins or roller chain adaptor. Order separately.	
32		Body – Lower Block, coil and roller chain	
	BH-1174	(1/4 and 1/2 ton hoists)	1
33	BH-1175	(1 ton hoists)	1*
		Hook, Nut and Latch Assembly – Lower Block	
	BH-1176	(1/4 and 1/2 ton Hoists)	1
	BH-1177	(1 ton Hoists)	1*

Figure 9-1. FRAME AND EXTERNAL PARTS – Continued

Ref. No.	Part Number	Description	Qty. Req'd.
34	BH-1182	Latch Kit – Hook, lower (1/4, and 1/2 ton Hoists)	1
	BH-1183	(1 ton Hoists)	1*
35	BH-1178	Washer – Thrust, needle bearing	2
36	BH-1179	Bearing Assembly – Needle, thrust	1
37	BH-1180	Shield – Bearing	1
38	BH-1181	Pin – Spring drive	1
39	**	Nut – Hook	1
40		Pin – Connecting, lower block (1/4 and 1/2 ton Hoists)	1
	BH-1037	(1 ton Hoists)	1*
41	BH-1045	Pin – Spring drive	1
42		Stripper – Roller Chain (1/4 and 1/2 ton Hoists)	1
	BH-1046	(1 & 2 ton Hoists)	1
43		Guide Assembly – Roller Chain (1/4 & 1/2 ton Hoists)	1
	BH-1048	(1 & 2 ton Hoists)	1
44		Link Assembly – Roller Chain (For connecting tail end of chain only – Must not be used to join chain.) (1/4 & 1/2 ton Hoists)	1
	BH-1050	(1 & 2 ton Hoists)	1
45	BH-1052	Screw – Fillister Head, Self Locking	1
46		Anchor – Link, roller load chain (1/4 & 1/2 ton Hoists)	1
	BH-1053	(1 & 2 ton Hoists)	1
	BH-1054	(1 & 2 ton Hoists)	1
47	††	Actuator – Limit Lever (For 1/4" Dia. Coil Chain and 5/8" Pitch Roller Chain)	2
	BH-1098	(For 5/16" Dia. Coil Chain and 3/4" Pitch Roller Chain)	2
48	BH-1184	Pin – Grooved (For Actuator BH-1098)	2
	BH-1185	Pin – Grooved (For Actuator BH-1099)	2
49	BH-1057	Bushing – Control Shaft	2
50	BH-1058	Filler Assembly – Oil	1
51	BH-1183	Latch Kit – Hook (upper) 1/4 thru 1 ton	1
52	BH-1089*	Pin – Spring drive	2
53	BH-1088*	Stud – Suspension, nut and pin (Includes item 55)	1
54	BH-1087*	Bracket – Suspension	1*
55	BH-1092	Washer (.0747 Thk.)	1
	BH-1186	Washer (.0478 Thk.)	As Req'd.
56	BH-1055	Screw & Integral Lockwasher – Round Head	2
57	BH-1056	Cover – Brake Opening	1
		The following items are for two speed hoists with 2-1/4 horsepower motor only:	
58	BH-1158	Insert - Coil	3
59		Support Stud	
	BH-1159	Top	2
	BH-1160	Bottom	1
60	BH-1161	Counterweight	1
61	BH-1162	Washer - Flat	3
62	BH-1163	Nut - Self-locking	3
63		Capacity Label	1
	BH-1164	1 Ton	
	BH-1165	2 Ton	
	BH-1166	3 Ton	

* Refer to Figure 9-2 for 2 Ton Model Upper Suspension, Load Chain and Lower Block Parts. Refer to Figure 9-3 for 3 Ton Model Upper Suspension, Load Chain and Lower Block Parts.

** Hook and suspension bolt nuts are not serviced separately. They are available only with hook or bolt as assemblies.

***	Load Chain Assemblies listed are for hoists with standard 10 ft. lifts. Bulk chain is available in 1 ft. increments and 50 ft. lengths as follows:	Type Chain	50' Lengths	Bulk
		Roller (5/8" Pitch)	BH-1064	BH-1065
		Roller (3/4" Pitch)	BH-1067	BH-1068
		Coil (1/4" Dia.)	Not Available	BH-1066
		Coil (5/16" Dia.)	Not Available	BH-1069
		Coil (1/4" Dia. cad.plate)	Not Available	BH-1083
		Coil (5/16" Dia. cad.plate)	Not Available	BH-1093

†† An urethane Bumper (BH-1063) is used over the top of the steel limit lever actuator at lower block on all high speed 64 fpm hoists, 32 fpm 1 Ton (2½ hp) hoists, and single phase 32 fpm hoists.

To enable us to expedite your parts order, always give Model and Catalog Number and Electric Current of Hoist. (See nameplate.)

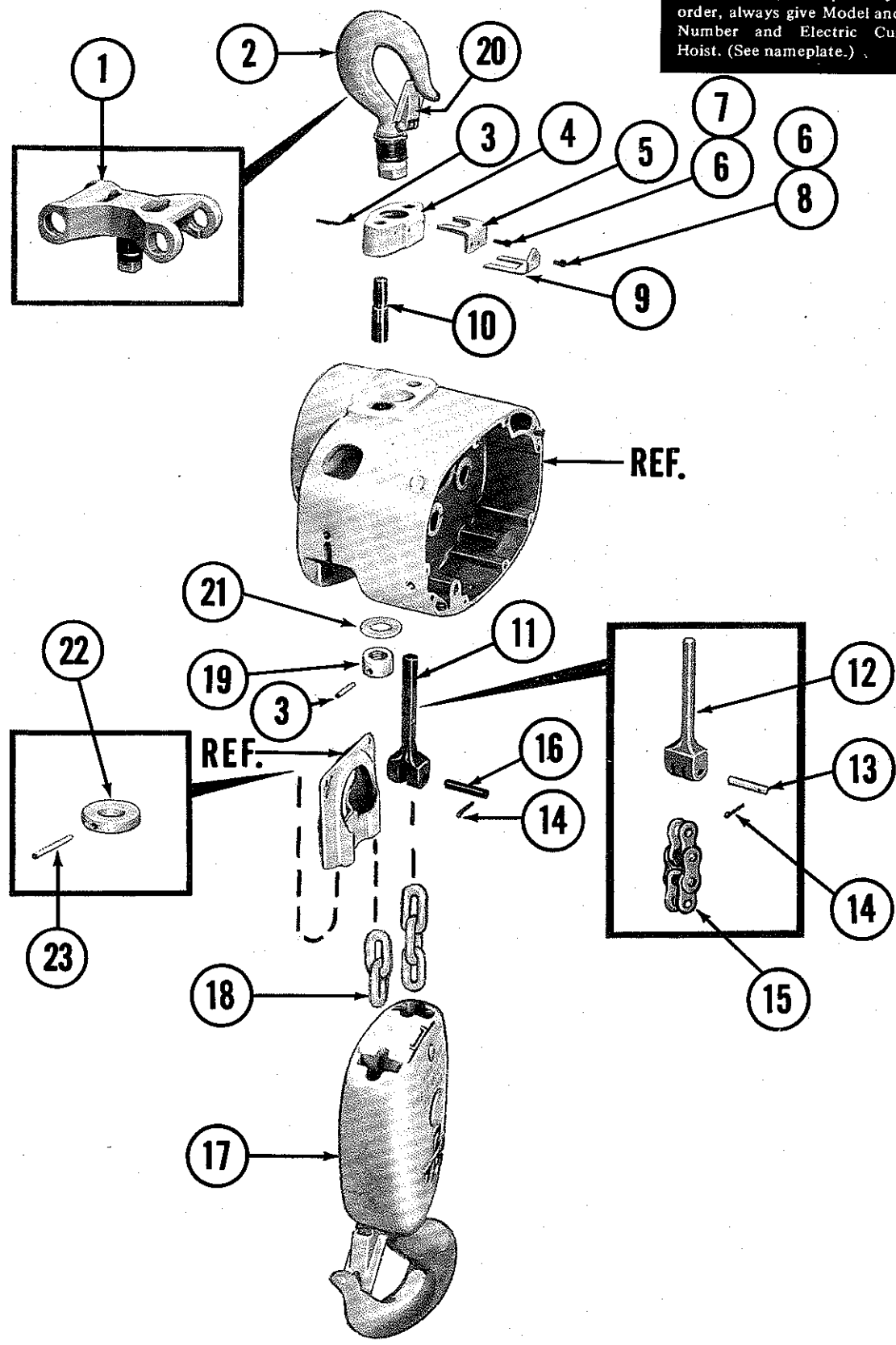

Figure 9-2. UPPER SUSPENSION, LOAD CHAIN AND LOWER BLOCK PARTS
(2 Ton Hoists)

10251B

Figure 9-2. UPPER SUSPENSION, LOAD CHAIN AND LOWER BLOCK PARTS - Continued

Ref. No.	Part Number	Description	Qty. Req'd.
1	905422	Bracket Assembly Kit - Lug Suspension (Coil Chain Model Only. Includes Items 6, 8 & 9).	1
2	BH-1102	Hook Assembly - Upper (Includes Item 5, 6, 7, & 20).	1
3	BH-1030	Pin - Drive	3
4	BH-1104	Block Assembly - Upper (Coil Chain Models. Includes Items 3, 10, 11, 14, 16, 19 & 21)	1
	BH-1105	(Roller Chain Models. Includes Items 3, 10 12, 13, 14, 19 & 21)	1
5	BH-1106	Lock Assembly - Suspension Bushing	1
6	BH-1107	Lockwasher	3
7	BH-1108	Screw - Hex. Socket Head	2
8	BH-1109	Screw - Hex. Socket Head	1
9	BH-1061	Plate - Lock (Coil Chain Lug Suspension Models Only)	1
10	*	Stud - Upper Block	1
11	*	Anchor - Coil Load Chain	1
12	*	Anchor - Roller Load Chain	1
13	BH-1110	Pin - Roller Chain Anchor	1
14	BH-1111	Pin - Cotter	1
15**	BH-1112	Chain Assembly - Roller Load (3/4" Pitch)	1
	BH-1076	Repair Link - 3/4" Pitch Roller Chain (Not Shown)	As Req'd.
16	BH-1113	Pin - Coil Chain Anchor	1
17	(See Fig. 9-12)	Block Assembly - Lower (Coil Chain Models)	1
	(See Fig. 9-13)	Block Assembly - Lower (Roller Chain Models)	1
18**	BH-1114	Chain Assembly - Coil Load	1
	BH-1115	Chain Assembly - Coil Load (Cad. Plated) Extra Heavy Duty Hoists	1
19	*	Nut - Upper Block Stud	1
20	BH-2213	Latch Kit - Hook	1
21	BH-1029	Washer - Thrust	1
22	BH-1099	Actuator - Limit Lever	1
23	BH-1185	Pin - Grooved	1

* Not available as individual parts. Order upper block assembly, Item 4.

** Load Chain Assemblies listed are for hoists with standard 10 ft. lifts. Bulk chain is available in 1 ft. increments and 50 ft. lengths as follows:

Type Chain	50' Lengths	Bulk
Roller (3/4" Pitch)	BH-1067	BH-1068
Coil (5/16" Dia.)	Not Available	BH-1069
Coil (6/16" Dia. cad. plate)	Not Available	BH-1093

To enable us to expedite your parts order, always give Model and Catalog Number and Electric Current of Hoist. (See nameplate.)

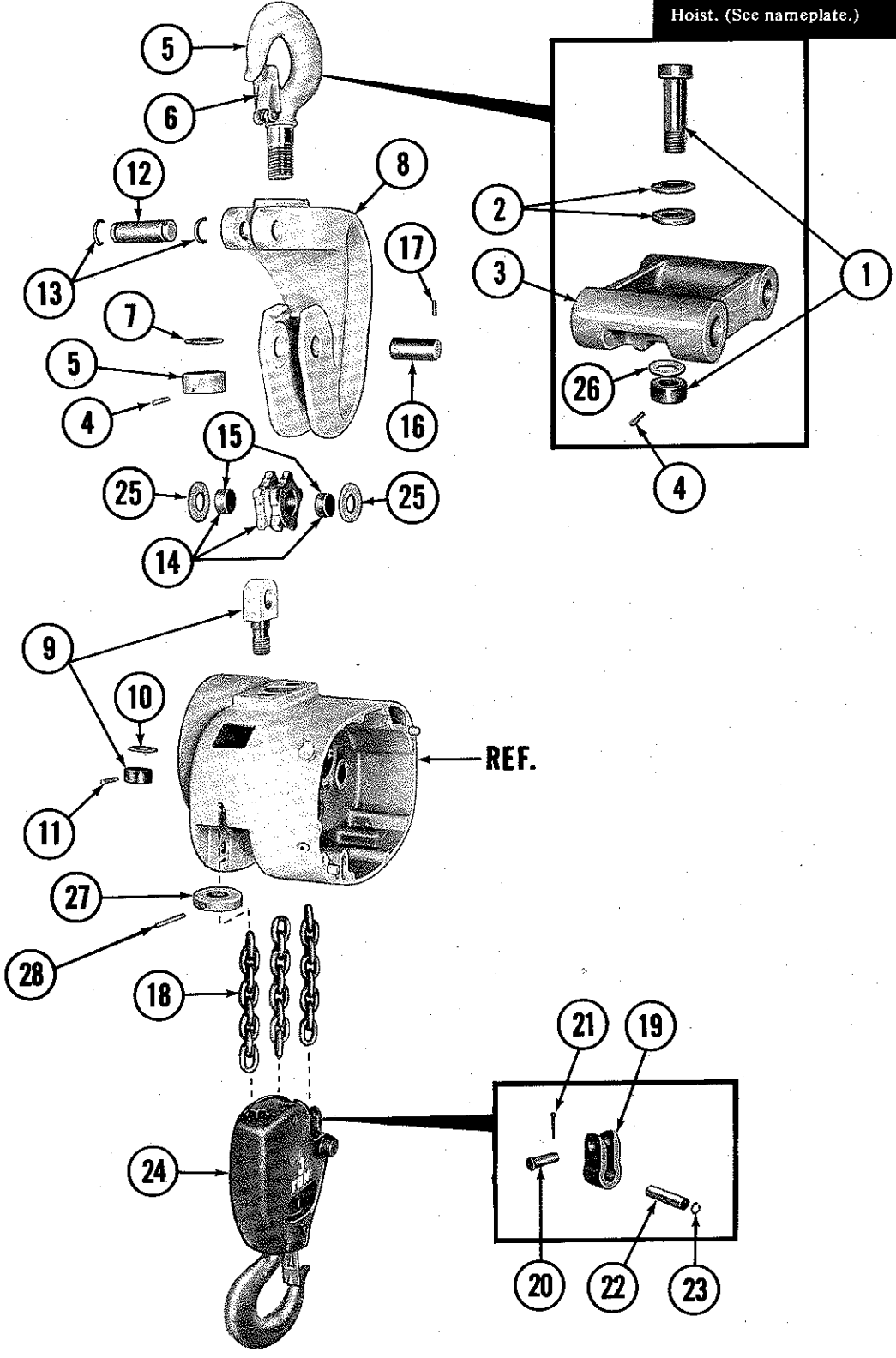

Figure 9-3. UPPER SUSPENSION, LOAD CHAIN AND LOWER BLOCK PARTS
(3 Ton Hoists)

11757B

Figure 9-3. UPPER SUSPENSION, LOAD CHAIN AND LOWER BLOCK PARTS - Continued

Ref. No.	Part Number	Description	Qty. Req'd.
1	BH-1131	Suspension Pin & Nut Assem.	1
2	BH-1132	Spherical Washer	1 Pr.
3	905424	Suspension Lug Kit (Includes Item 1, 2, 4 & 26)	1
4	BH-1134	Pin - Grooved	1
5	BH-1135	Hook/Latch & Nut (Includes Item 6)	1
6	BH-2214	Latch Kit, Hook	1
7	BH-2217	Washer, Thrust	1
8	BH-1138	Hanger	1
9	BH-1139	Connecting Rod Assem.	1
10	BH-1029	Washer, Thrust	1
11	BH-1030	Pin, Grooved	1
12	BH-1142	Pin, Connection	1
13	BH-1143	Ring, Retaining	2
14	BH-1144	Sprocket & Bushing Assem. (Includes Item 15)	1
15	BH-1145	Bushing	2
16	BH-1146	Pin, Sprocket	1
17	BH-1147	Pin, Grooved	1
18	BH-1148	Chain Assembly, Coil Load	1
19	BH-1149	Link, Connecting	1
20	BH-1150	Pin, Anchor	1
21	BH-1151	Pin, Cotter	1
22	BH-1152	Pin, Dowel	1
23	BH-1153	Ring, Retaining	1
24	(See Fig. 9-12)	Block Assembly, Lower, Coil Chain	
25	BH-2210	Washer, Thrust	2
26	BH-1154	Washer	1
27	BH-1099	Actuator - Limit Lever	1
28	BH-1185	Pin - Grooved	1

NOTICE

Always insist on factor approved **BUDGIT** Hoist replacement parts when servicing this equipment. Parts are available from your local Authorized Repair Station.

To enable us to expedite your parts order, always give Model and Catalog Number and Electric Current of Hoist. (See nameplate.)

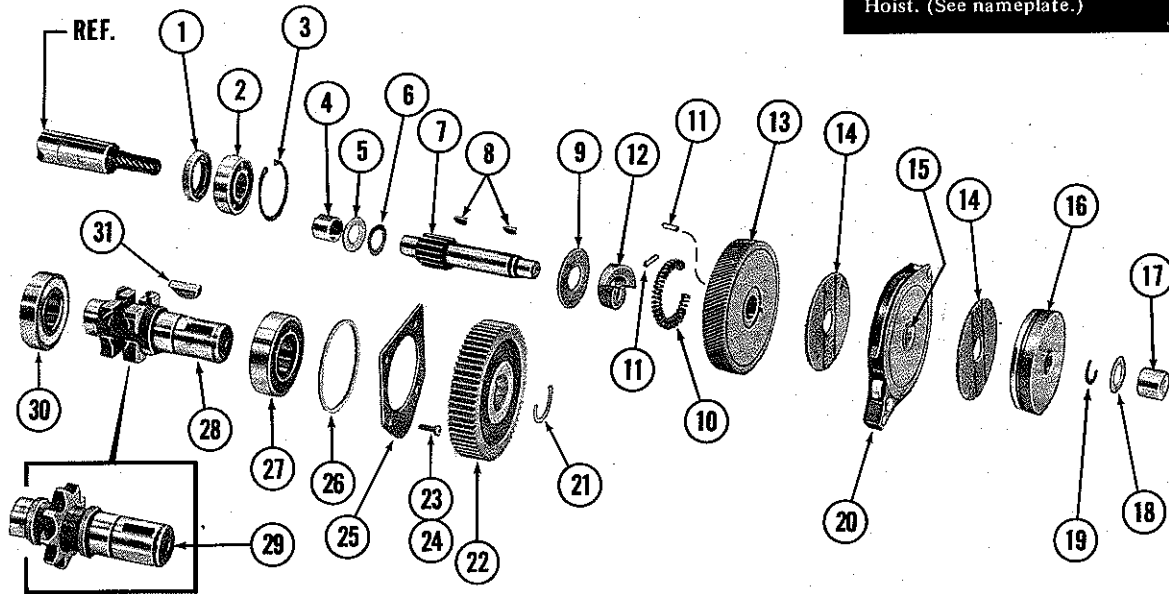

11898

Figure 9-4. GEARING AND LOAD BRAKE PARTS
(1/4 & 1/2 Ton Hoists)

Ref. No.	Part Number	Description	Qty. Req'd.
1	BH-1201	Seal – Oil, motor shaft	1
2	BH-1202	Bearing Assembly – Ball, motor shaft	1
3	BH-1203	Ring – Retaining, Internal	1
4	BH-1237	Bearing Assembly – Needle, 11/16" I.D. (36 rollers, grease retained)	1
5	BH-1205	Bearing – Thrust, bronze	1
6	BH-1206	Washer – Thrust, 11/16" I.D. (Used with 14 tooth Pinion Load Brake Shaft – BH-1207 below)	1
7	BH-1207	Shaft & Integral Pinion – load brake, 14 teeth	1
	BH-1208	23 teeth	1
	BH-1209	36 teeth	1
8	BH-1210	Key – Woodruff	2
9	BH-1239	Retainer – Spring, load brake	1
10	BH-1212	Spring – load brake (Plain – no color code)	1
	BH-1213	Spring – load brake (Yellow color code)	1
11	BH-1214	Pin – Grooved	2
12	BH-1216	Cam – load brake	1
13	*	Gear & Clutch Assembly – load brake	
	BH-1240	(For use with 1/4 H.P. Motor)	1
	BH-1241	(For use with 1/2 H.P. Motor)	1
	BH-1242	(For use with 1 H.P. Motor)	1
14	BH-1218	Disc – Friction, load brake	2
15	BH-1238	Bushing – Ratchet	2
16	BH-1219	Flange – load brake	1
17	BH-1220	Bearing Assembly – Needle, 5/8" I.D.	1
18	BH-1221	Washer – Thrust, 5/8" I.D.	1
19	BH-1222	Ring – Snap, brake flange	1
20	BH-1223	Pawl & Ratchet Assembly – load brake (includes item 15)	1
21	BH-1224	Ring – Snap, sprocket gear	1
22		Gear – Sprocket	
	BH-1225	74 teeth	1
	BH-1226	65 teeth	1
	BH-1227	52 teeth	1

(Continued on following page.)

Figure 9-4. GEARING AND LOAD BRAKE PARTS – Continued

Ref. No.	Part Number	Description	Qty. Req'd.
23	BH-1228	Screw – Fillister Head Machine	4
24	BH-1229	Lockwasher – Spring Type	4
25	BH-1230	Plate – Retainer, sprocket bearing	1
26	BH-1231	Gasket – Ring, sprocket bearing	1
27	BH-1232	Bearing Assembly – Ball, sprocket	1
28	BH-1233	Sprocket – Coil chain (1/4" Dia. Wire)	1
29	BH-1234	Sprocket – Roller chain (5/8" Pitch)	1
30	BH-1235	Bearing Assembly – Ball, sprocket	1
31	BH-1236	Key – Woodruff	1

* This gear and clutch assembly should not be field disassembled. Replace assembly only as clutch pressure is preset at factory based on hoist capacity and motor H.P.

NOTES

Horizontal lines provided for notes.

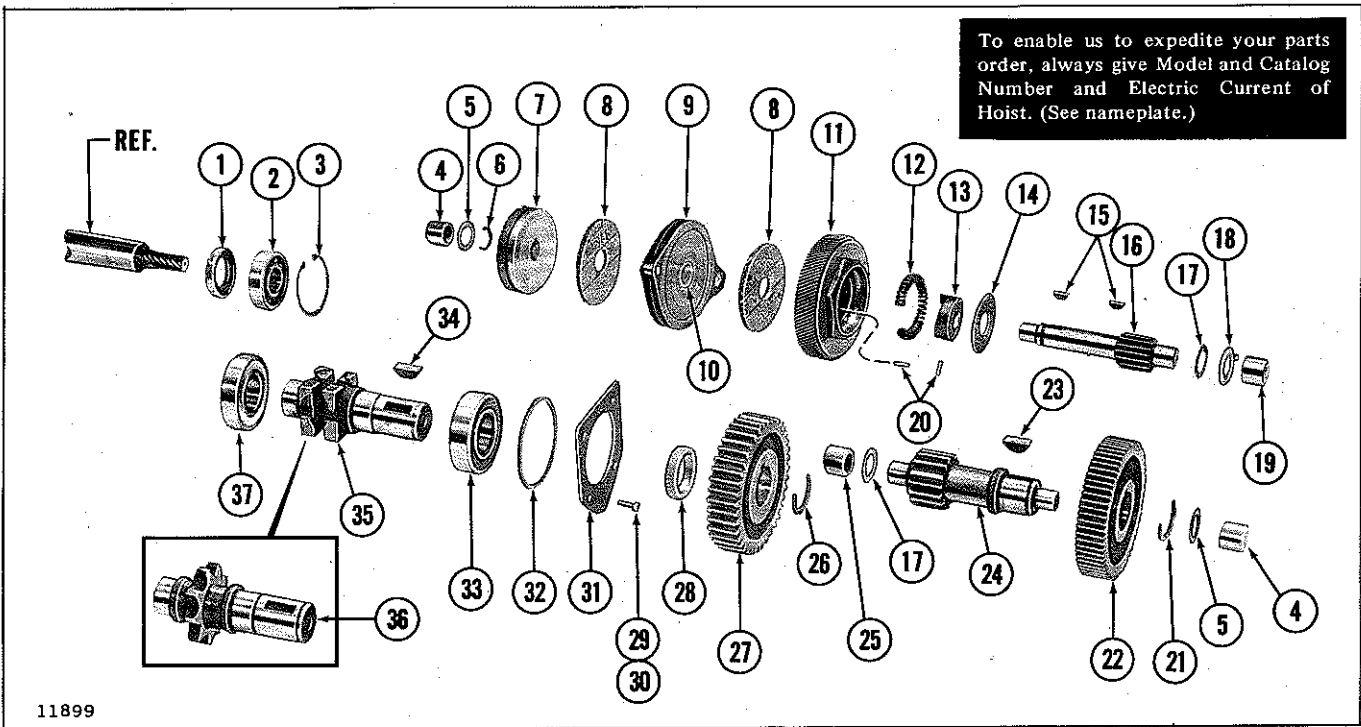

Figure 9-5. GEARING AND LOAD BRAKE PARTS – (1, 2 & 3 Ton Hoists)

Ref. No.	Part Number	Description	Qty. Req'd.
1	BH-1201	Seal – Oil, motor shaft	1
2	BH-1202	Bearing Assembly – Ball, motor shaft	1
3	BH-1203	Ring – Retaining, Internal	1
4	BH-1220	Bearing Assembly – Needle, 5/8" I.D.	2
5	BH-1221	Washer – Thrust, 5/8" I.D.	2
6	BH-1222	Ring – Snap, brake flange	1
7	BH-1219	Flange – Load Brake	1
8	BH-1218	Disc – Friction, load brake	2
9	BH-1223	Pawl & Ratchet Assembly – Load Brake (includes item 15)	1
10	BH-1238	Bushing – Ratchet	1
11	*	Gear & Clutch Assembly.– Load Brake	
	BH-1241	(For use with 1/2 H.P. Motor)	1
	BH-1242	(For use with 1 & 2-1/2 H.P. Motors)	1
12	BH-1212	Spring – Load Brake (Plain – no color code)	1
13	BH-1216	Cam – Load Brake	1
14	BH-1239	Retainer – Spring, Load Brake	1
15	BH-1210	Key – Woodruff	2
16		Shaft & Integral Pinion – Load Brake	
	BH-1207	14 teeth	1
	BH-1208	23 teeth	1
17	BH-1206	Washer – Thrust, 11/16" I.D.	2
18	BH-1205	Bearing – Thrust, bronze	1
19	BH-1204	Bearing Assembly – Needle, 11/16" I.D.	1
20	BH-1214	Pin – Grooved	2
21	BH-1224	Ring – Snap, intermediate gear	1
22		Gear – Intermediate	
	BH-1225	74 teeth	1
	BH-1226	65 teeth	1
23	BH-1236	Key – Woodruff	1
24	BH-1304	Shaft & Integral Pinion – Intermediate	1
25	BH-1237	Bearing Assembly – Needle, 11/16" I.D. (36 roller, greased retained)	1
26	BH-1305	Ring – Snap, sprocket gear	1
27	BH-1306	Gear – Sprocket	1
28	BH-1307	Spacer – Sprocket Gear	1
29	BH-1228	Screw – Fillister Head Machine	4

(Continued on following page.)

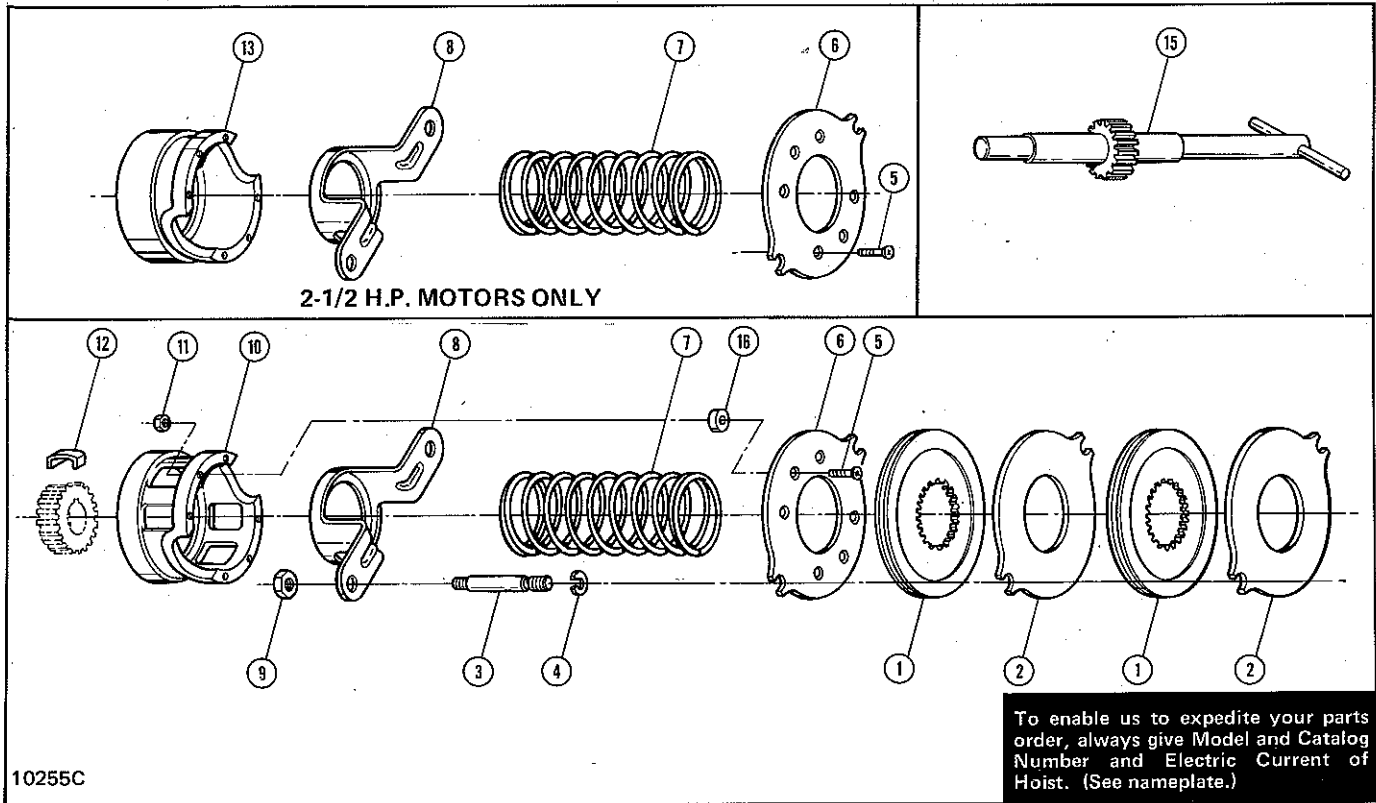

Figure 9-6. STATOR OPERATED MOTOR BRAKE PARTS
(3 Phase, Standard Model Hoists & Extra Heavy Duty Hoists)

Ref. No.	Part Number	Description	Quantity Required		
			¼ & ½ HP Motors with 1 Brake Disc Assembly Only	¼, ½, 1 & 2½ HP Motors	2½ HP Motors for Hoists with Model Numbers Beginning with 115307 Only
1	BH-1405	Disc Assembly – Friction	1	2	2
2	BH-1404	Plate – Friction	1	2	2
3	BH-1501	Pin – Support, plate	2	2	2
4	BH-1407	Ring – Retaining	2	2	2
5	BH-1502	Screw – Flat Socket Head	–	6	6
	BH-1515	Screw – Flat Socket Head	6	–	–
6	*	Plate – Compression	1	1	1
7	BH-1504	Spring – Compression (1/4 & 1/2 HP Motors)	–	1	–
	BH-1505	Spring – Compression (Color Coded Green)	1	1	1
8	*	Cage – Spring	1	1	1
9	BH-1507	Nut – Hex, self locking	2	2	2
10	*	Plunger (1/4, 1/2 & 1 HP Motors)	1	1	–
11	BH-1509	Nut – Hex, self locking	6	6	–
12	BH-1435	Spring – Friction Disc (Not Used on Extra Heavy Duty Hoists)	1	1	1
13	*	Plunger (2½ H.P. Motor)	–	1	–
	*	Plunger	–	–	1
15	224704-1	Tool – Brake Disc Alignment	1	1	1
16	BH-1516	Spacer – Brake Plunger	6	–	–

*These items not available separately (for assemblies see below)

- BH-1513 Cage & Plunger Assembly (Includes Ref. Nos. 5, 6, 8, 10, 11 & 16)
For ¼ & ½ HP Motors with 1 Brake Disc Assembly Only.
- BH-1511 Cage & Plunger Assembly (Includes Ref. Nos. 5, 6, 8, 10 & 11)
For 1/4 (Except Above), ½ (Except Above) & 1 HP Motors.
- BH-1512 Cage & Plunger Assembly (Includes Ref. Nos. 5, 6, 8 & 13)
For 2-1/2 (Except Below) HP Motors.
- BH-1514 Cage & Plunger Assembly (Includes Ref. Nos. 5, 6, 8 & 13)
For 2-1/2 HP Motors For Hoists With Model Numbers Beginning With 115307 Only.

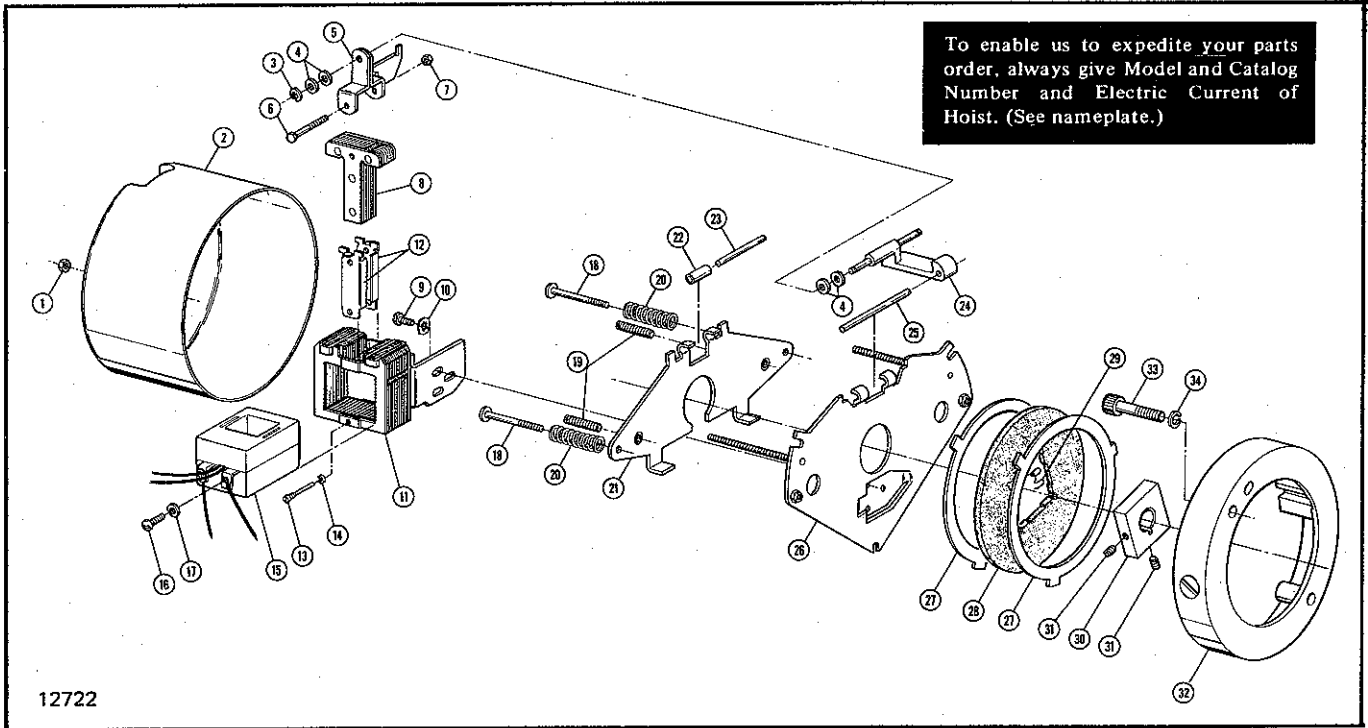

Figure 9-6A. SOLENOID OPERATED MOTOR BRAKE PARTS
(Two Speed Hoists Only)

Ref. No.	Part Number	Description	Qty. Req'd.
		Brake Assembly (Includes Ref. Nos. 1 thru 32) 230V/460V and 208V/416V	1
	BH-1550	240V/480V	
	BH-1551	575V	
	BH-1552	Housing Kit (Includes Ref. Nos. 1 and 2)	1
1		Nut	2
2		Housing	1
3	BH-1554	Ring-Retaining	1
4	BH-1555	Spacer	4
	BH-1556	Solenoid Kit (Includes Ref. Nos. 5 thru 11)	1
5		Link-Solenoid	1
6		Screw-Cap	1
7		Nut	1
8		Plunger	1
9		Screw-Mounting	3
10		Lockwasher	3
11		Frame	1
		Coil Kit (Includes Ref. Nos. 12 thru 17)	1
	BH-1557	230V/460V and 208V/416V	
	BH-1558	240V/480V	
	BH-1559	575V	
12		Guide - Plunger	2
13		Screw - Guide	1
14		Lockwasher	1
15		Coil	1
16		Screw-Terminal	2
17		Lockwasher	2
18	BH-1560	Screw - Torque Adjustment	2
19	BH-1561	Screw - Wear Adjustment	2
20	BH-1562	Spring - Pressure	2
21	BH-1563	Plate - Lever Arm	1
22	BH-1564	Bearing	1

(Continued on following page.)

Figure 9-6A. EXTERNAL MOTOR BRAKE PART - Continued

Ref. No.	Part Number	Description	Qty. Req'd.
23	BH-1565	Pin - Bearing	1
24	BH-1566	Lever - Solenoid	1
25	BH-1567	Pin - Pivot	1
26	BH-1568	Plate - Support	1
27	BH-1569	Stationary Disc	2
	BH-1570	Friction Disc and Spring Kit (Each Kit Includes 3 Friction Discs and 6 Springs) (Includes Ref. Nos. 28 and 29)	1
		Friction Disc	1
		Spring	2
	BH-1571	Hub Kit (Includes Ref. Nos. 30 and 31)	1
		Hub	1
		Screw - Set	2
	BH-1572	Endplate	1
	BH-1573	Screw - Socket Head Cap	2
	BH-1574	Lockwasher	2

NOTES

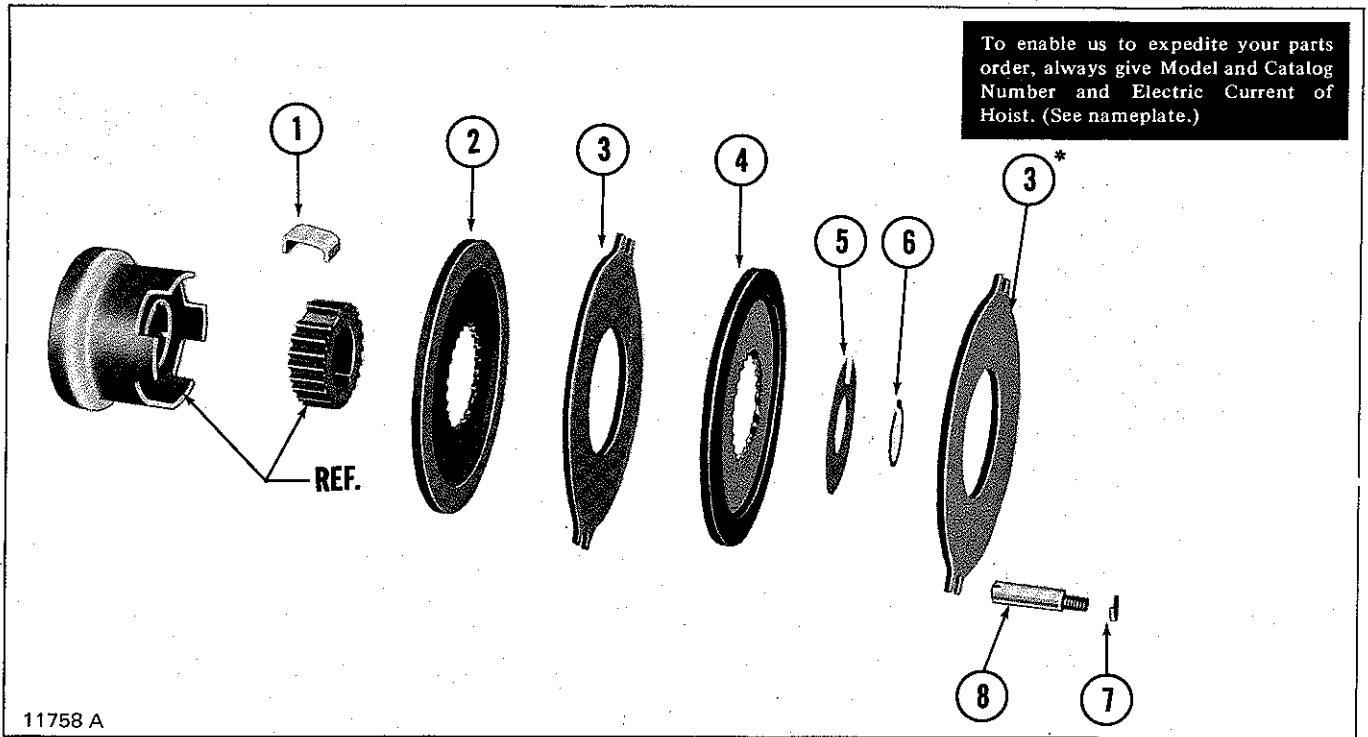

Figure 9-7. ROTOR OPERATED MOTOR BRAKE PARTS
(Single Phase, Standard Model Hoists)

Ref. No.	Part Number	Description	Qty. Req'd.
1	BH-1435	Spring, Friction Disc.	1
2	BH-1610	Disc Assembly - Brake	1
3	BH-1404	Plate - Friction	2
4	BH-1405	Disc Assembly - Friction	1
5	BH-1611	Washer - Retainer	1
6	BH-1604	Ring - Retaining	1
7	BH-1407	Ring - Retaining	2
8	BH-1605	Pin - Support, brake plate	2

*Above plate not mounted on splined hub, it lies loose over support pins in frame.

NOTES

To enable us to expedite your parts order, always give Model and Catalog Number, and Electric Current of Hoist. (See nameplate.)

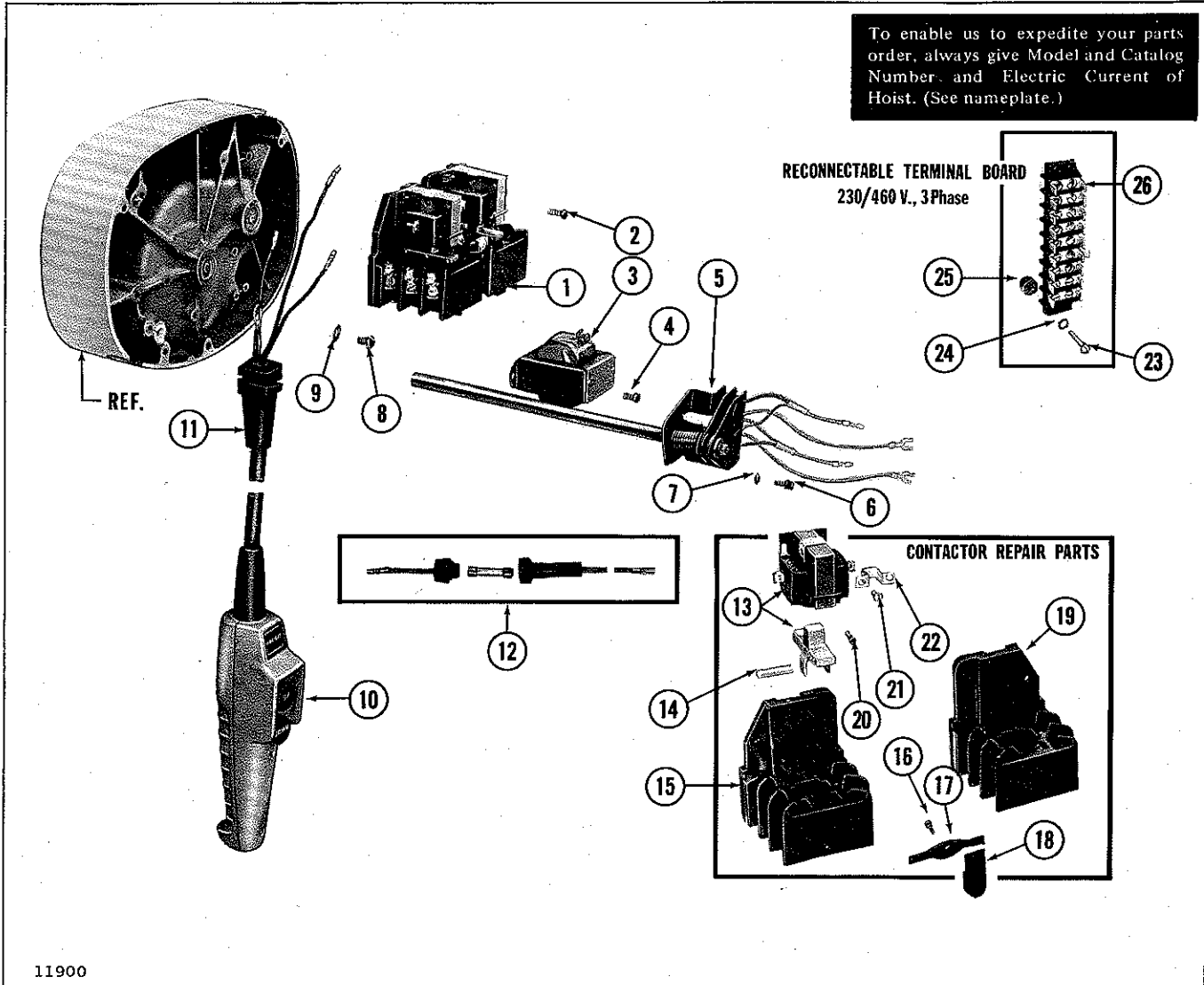

11900

Figure 9-8. ELECTRICAL CONTROL UNITS
(Early Model Hoists)

Ref. No.	Part Number	Description	Quantity Required			
			115/1/60	230/1/60	All 3 Phase	
1	BH-2101	Contactors Assembly – Complete, 115 v. Coil	1	1	—	
	BH-2102	Contactors Assembly – Complete, 24 v. Coil	1	1	—	
	BH-2103	Contactors Assembly – Complete, 24 v. Coil	—	—	1	
	BH-2145	Contactors Assembly – Complete, 115v. Coil	—	—	1	
2	BH-1701	Screw & Integral Lockwasher – Rd. Hd.	2	2	2	
	BH-1706	Transformer – 115v./24v.	1	—	—	
3	BH-1703	Transformer – 230v./24v.	—	1	—	
	BH-1716	Transformer – 230v./115v.	—	1	—	
	BH-1702	Transformer – 208v./24v.	—	—	1	
	BH-1715	Transformer – 208v./115v.	—	—	1	
	BH-1705	Transformer – 575v./24v.	—	—	1	
	BH-1718	Transformer – 575v./115v.	—	—	1	
	BH-1707	Transformer – 230-460v./24v.	—	—	1	
	BH-1719	Transformer – 230-460v./115v.	—	—	1	
	4	BH-1708	Screw & Integral Lockwasher – Round Head	2	2	2
	5	(See Fig. 9-9)	Switch & Shaft Assembly – Limit	1	1	1
6	BH-1709	Screw – Hex Socket Head	2	2	2	
7	BH-1710	Lockwasher	2	2	2	
8	BH-1711	Screw – Round Head Machine	1	1	1	
9	BH-1712	Washer – Flat	2	2	2	

(Continued on following page.)

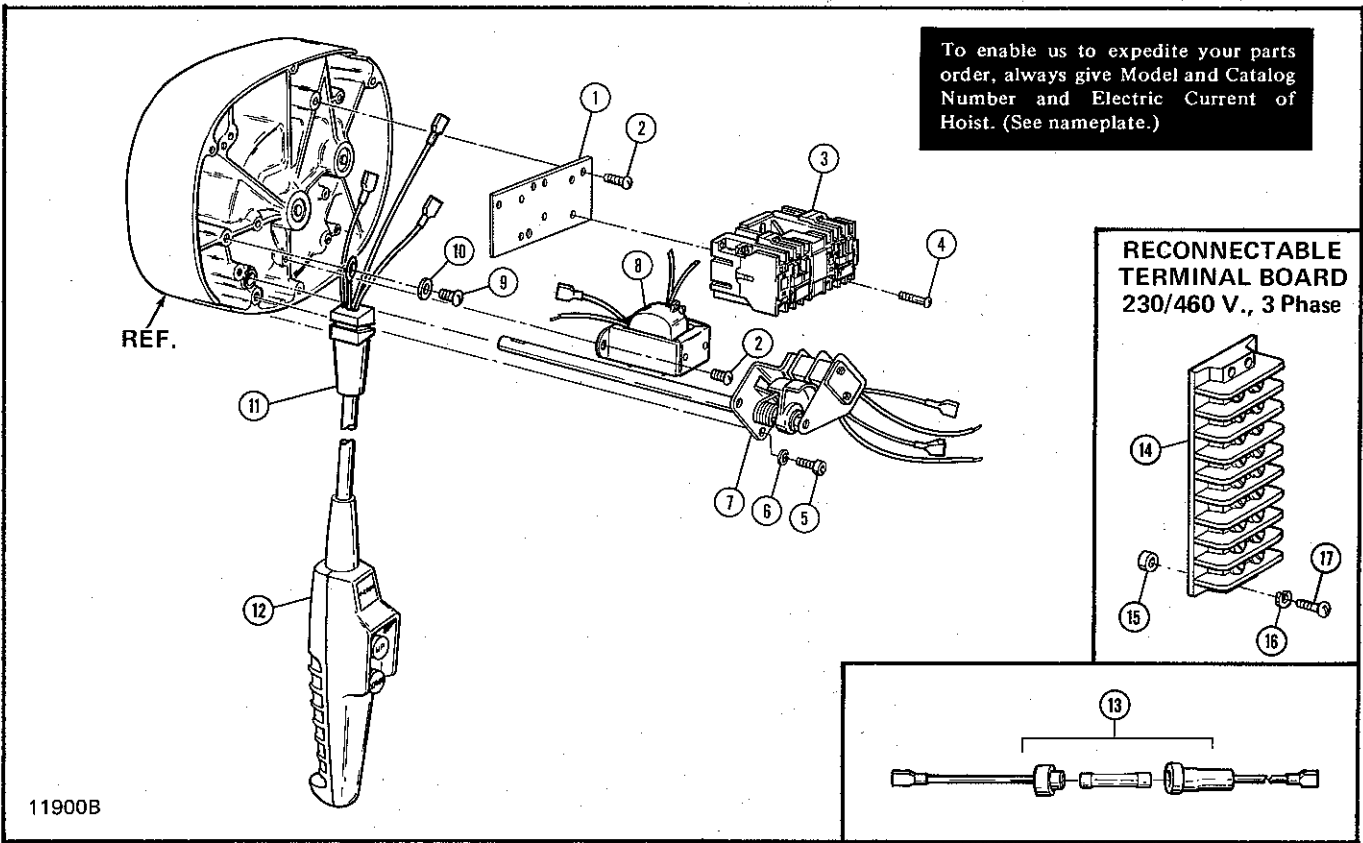

Figure 9-8A. ELECTRICAL CONTROL UNITS
(Late Model Hoists)

Ref. No.	Part Number	Description	Qty. Req'd.	
1	BH-2150	Contactor and Mounting Plate Assembly (Includes Ref. Nos. 1, 3 and 4)	1	
	BH-2151	Three Phase 24V Control		
	BH-2152	Three Phase 115V Control		
	BH-2153	Single Phase 24V Control		
	BH-2153	Single Phase 115V Control		
	BH-2154	Mounting Plate - Contactor	1	
	2	BH-2155	Screw - Round Head Machine	4
		BH-2156	Contactor Assembly	1
		BH-2156	Three Phase 24V Control	
		BH-2157	Three Phase 115V Control	
	3	BH-2158	Single Phase 24V Control	
		BH-2159	Single Phase 115V Control	
		BH-2160	Screw - Round Head Machine	2
BH-2161		Screw - Hex Socket Head	2	
4	BH-2162	Lockwasher	2	
5	See Fig. 9-9A	Limit Switch and Shaft Assembly	1	
6		Transformer	1	
7	BH-2163	Single Phase 115V/24V		
8	BH-2164	Single Phase 230V/24V		
	BH-2165	Single Phase 230V/115V		
	BH-2166	Three Phase 208V/24V		
	BH-2164	Three Phase 230V/24V		
	BH-2167	Three Phase 460V/24V		
	BH-2168	Three Phase 575V/24V		
	BH-2169	Three Phase 208V/115V		
	BH-2170	Three Phase 230V/115V		
	BH-2171	Three Phase 460V/115V		
	BH-2172	Three Phase 575V/115V		

(Continued on following page.)

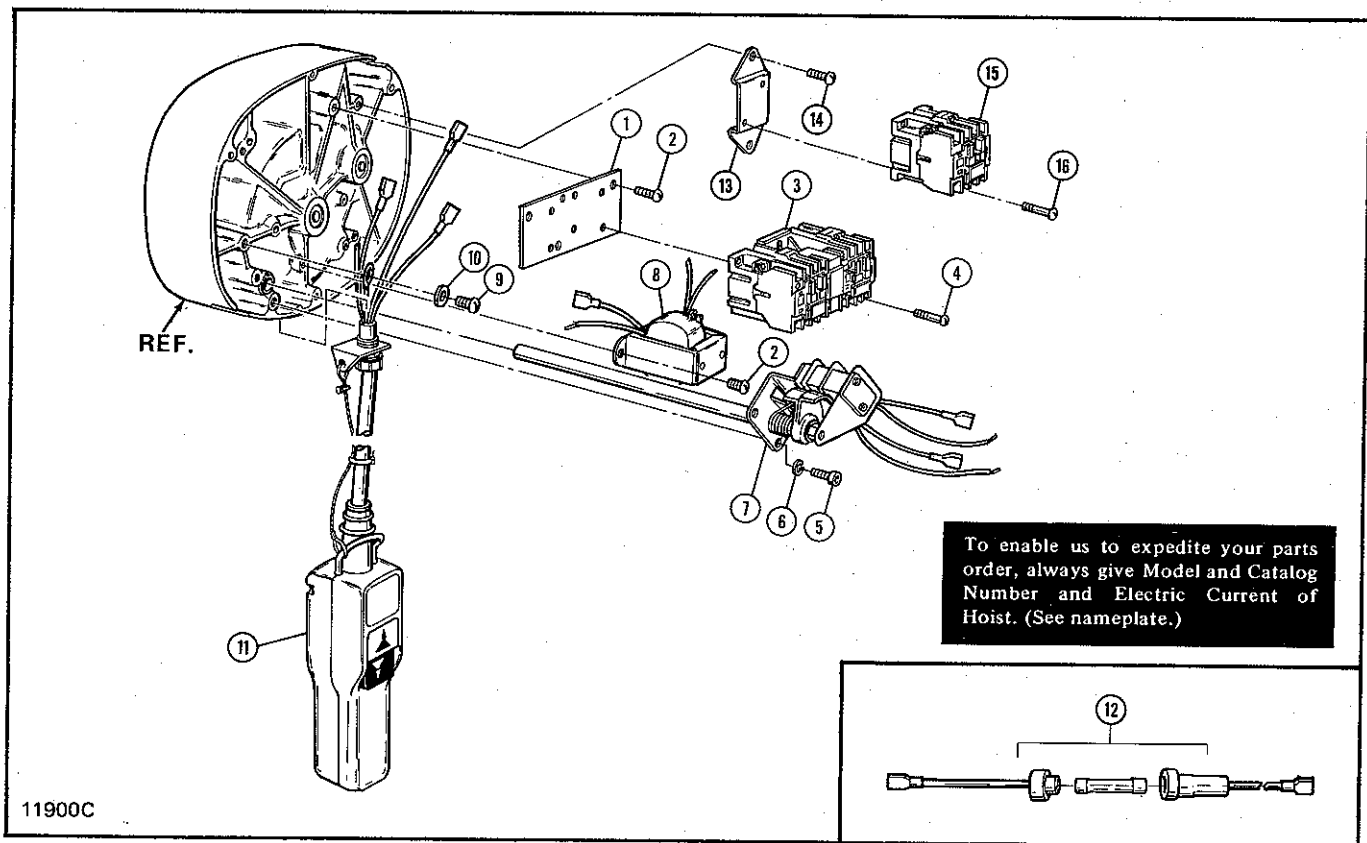
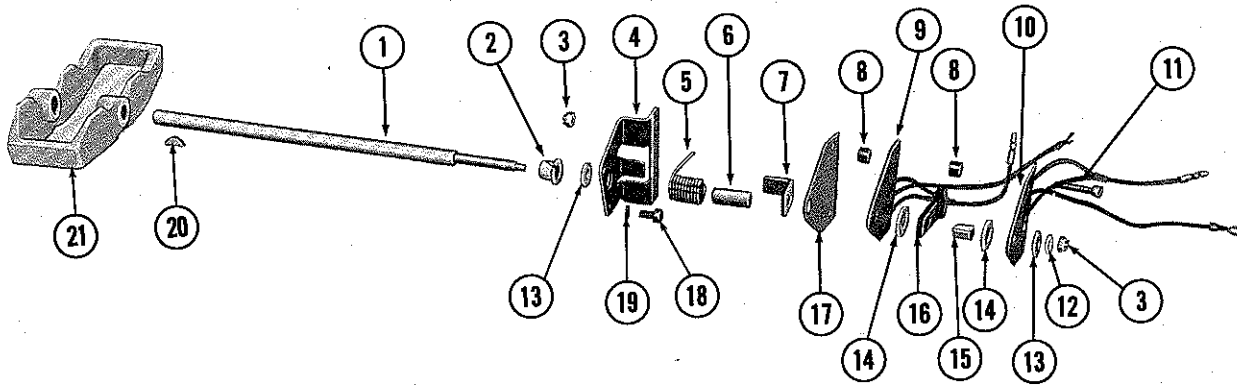

Figure 9-8B. ELECTRICAL CONTROL UNITS
(Two Speed Hoists Only.)

Ref. No.	Part Number	Description	Qty. Req'd.	
1	BH-2150	Contactor and Mounting Plate Assembly (Includes Ref. Nos. 1, 3 and 4)	1	
	BH-2151	Three Phase 24V Control		
	BH-2152	Three Phase 115V Control		
	BH-2153	Single Phase 24V Control		
	BH-2154	Single Phase 115V Control		
	2	BH-2154	Mounting Plate - Contactor	1
	3	BH-2155	Screw - Round Head Machine	4
			Contactor Assembly	1
		BH-2156	Three Phase 24V Control	
		BH-2157	Three Phase 115V Control	
		BH-2158	Single Phase 24V Control	
		BH-2159	Single Phase 115V Control	
	4	BH-2160	Screw - Round Head Machine	2
	5	BH-2161	Screw - Hex Socket Head	2
	6	BH-2162	Lockwasher	2
	7	See Fig. 9-9A	Limit Switch and Shaft Assembly	1
8		Transformer	1	
	BH-2163	Single Phase 115V/24V		
	BH-2164	Single Phase 230V/24V		
	BH-2165	Single Phase 230V/115V		
	BH-2166	Three Phase 208V/24V		
	BH-2164	Three Phase 230V/24V		
	BH-2167	Three Phase 460V/24V		
	BH-2168	Three Phase 575V/24V		
	BH-2169	Three Phase 208V/115V		
	BH-2170	Three Phase 230V/115V		
	BH-2171	Three Phase 460V/115V		
	BH-2172	Three Phase 575V/115V		

(Continued on following page.)

To enable us to expedite your parts order, always give Model and Catalog Number and Electric Current of Hoist. (See nameplate.)



11901

Figure 9-9. LIMIT LEVER AND SWITCH PARTS
(Early Model Hoists)

Ref. No.	Part Number	Description	Qty. Req'd.
1	BH-1825	Switch & Shaft Assembly – Limit (Includes Items 1 & 3 thru 17)	1
1	BH-1802	Shaft – Control	1
2	BH-1422	Bearing – Flanged Sleeve	1
3	*	Nut – Hex, self locking	3
4	*	Bracket – Retainer	1
5	BH-1417	Spring – Centering	1
6	*	Tube – Spacer	1
7	*	Lever – Centering	1
8	*	Spacer	4
9	BH-1828	Contact Board & Wire Assembly – “Up” Limit Switch	1
10	BH-1829	Contact Board & Wire Assembly – “Down” Limit Switch	1
11	*	Screw – Round Head Cap	2
12	BH-1819	Washer – Flat	1
13	*	Washer – Spacer	2
14	*	Washer – Spacer, contact slide arm	2
15	*	Spacer – Drive, contact slide arm	1
16	BH-1815	Arm Assembly, contact slide	1
17	*	Insulation Strip	1
18	BH-1419	Screw – Hex Socket Head	2
19	BH-1420	Lockwasher – Spring Type	2
20	BH-1424	Key – Woodruff	1
21	BH-1830	Lever – Limit	1
22	BH-1822	Jumper Wire Assem. – 115 volt without Transformer (not illustrated)	1
**23	BH-1823	Fuse, Fuse Holder and Wire Assem. (w/½A. Fuse) for 115V. Transformer	1
**24	BH-1824	Fuse, Fuse Holder and Wire Assem. (w/3A. Fuse) for 24V. Transformer	1
25	BH-1826	Connector – Wire, Insulated (Not Illustrated)	3

Note: Replacement fuses are standard automotive type and should be purchased locally.

*Furnished only with limit switch and shaft assembly.

**See Fig. 9-8 for illustration.

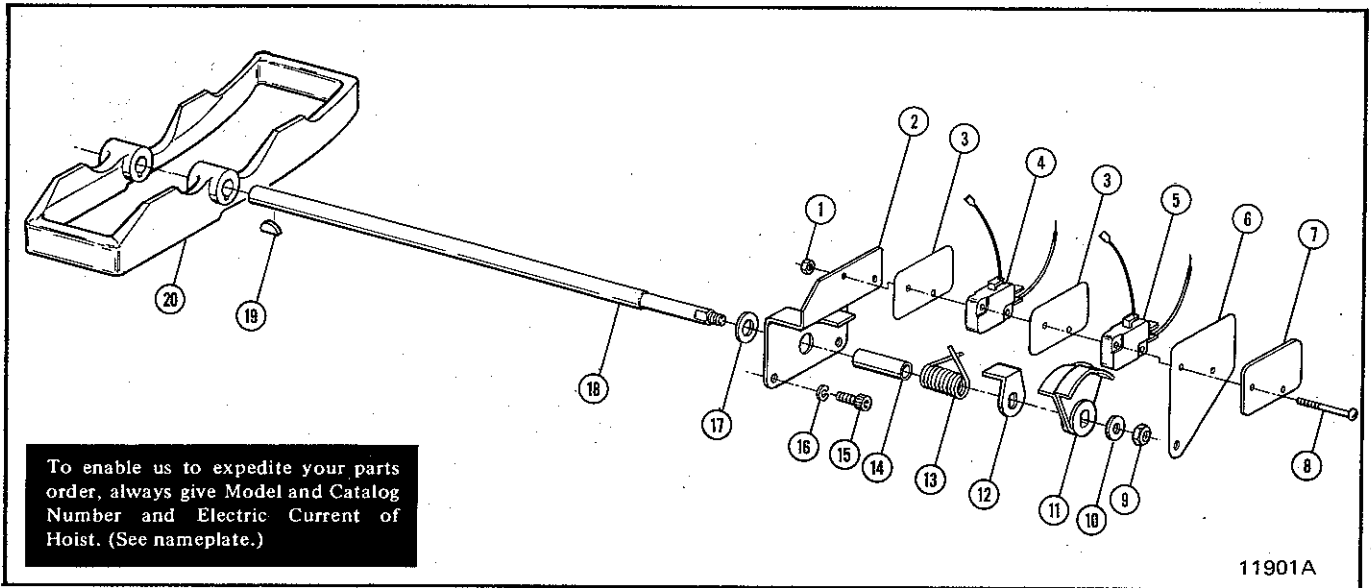

Figure 9-9A. LIMIT LEVER AND SWITCH PARTS
(Late Model Hoists)

Ref. No.	Part Number	Description	Qty. Req'd.
	BH-1850	Limit Switch and Shaft Assembly (Includes Ref. Nos. 1 thru 14 and 17 and 18)	1
1	BH-1851	Nut - Self-locking	2
2	BH-1852	Retainer	1
3	BH-1853	Insulation	2
4	BH-1854	Limit Switch - Upper	1
5	BH-1855	Limit Switch - Lower	1
6	BH-1856	Insulation	1
7	BH-1857	Plate - Cover	1
8	BH-1858	Screw - Round Head Machine	1
9	BH-1859	Nut - Self-locking	2
10	BH-1860	Washer - Flat	1
11	BH-1861	Switch Actuator	1
12	BH-1862	Centering Lever	1
13	BH-1863	Spring - Control	1
14	BH-1864	Spacer	1
15	BH-1865	Screw - Hex Socket Head	2
16	BH-1866	Lockwasher	2
17	BH-1867	Washer - Flat	1
18	BH-1868	Control Shaft	1
19	BH-1869	Key - Woodruff	1
20	BH-1870	Limit Lever	1

To enable us to expedite your parts order, always give Model and Catalog Number and Electric Current of Hoist. (See nameplate.)

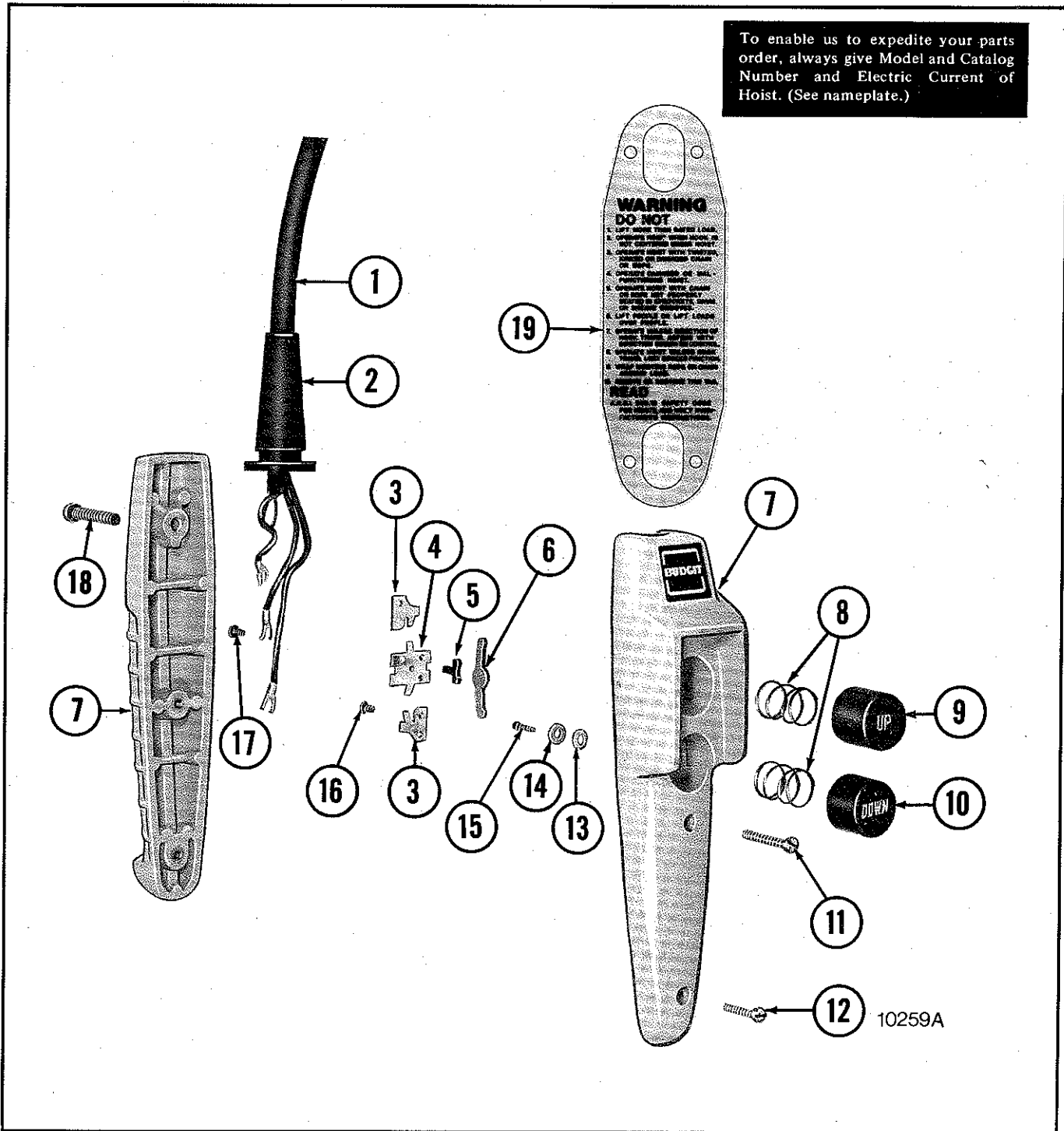

Figure 9-10. PUSH BUTTON STATION & CONDUCTOR CABLE ASSEMBLY
(Standard Model Hoists)

Figure 9-10. PUSH BUTTON STATION & CONDUCTOR CABLE ASSEMBLY - Continued

Ref. No.	Part Number	Description	Qty. Req'd.
* 1*	BH-1901 BH-1902	Push Button Station & Conductor Cable Assembly Cable Assembly - Conductor, flexible (Includes upper and lower grommets)	1 1
2	BH-1903 BH-1904	Grommet - Strain Reliever, lower Station Assembly - Push Button (Includes Items 3 thru 19)	1 1
3	**	Contact - Stationary	2
4	**	Contact - Stationary, center	1
5	**	Retainer - Interlock Bar	2
6	**	Bar - Interlock	2
7	BH-1909	Body Assembly (Front & Rear Halves)	1
8	BH-1910	Spring - Push Button	2
9	BH-1911	Button - Push, "Up"	1
10	BH-1912	Button - Push, "Down"	1
11	BH-1913	Screw - Fillister Head Machine	1
12	BH-1914	Screw - Fillister Head Machine	1
13	**	Spring - Contact	2
14	**	Contact - Movable	2
15	**	Screw - Shoulder	2
16	**	Screw - Round Head Machine	6
17	**	Screw - Pan Head Machine, plated	3
18	BH-1921	Screw - Fillister Head Machine	1
19	BH-1923	Label - Operator Warning (A.N.S.I.)	1

* These assemblies are for standard 10' lift hoists. When ordering replacements for hoists with other than standard lifts, specify lift.

** These parts not available separately. Order Contact Kit - BH-1922.

Later model push button stations use a brass standoff (not shown, BH-1940) to hold the strain cable to the station body front. Ref. No. 18 then threads into the standoff (new number, BH-1941).

NOTES

To enable us to expedite your parts order, always give Model and Catalog Number and Electric Current of Hoist. (See nameplate.)

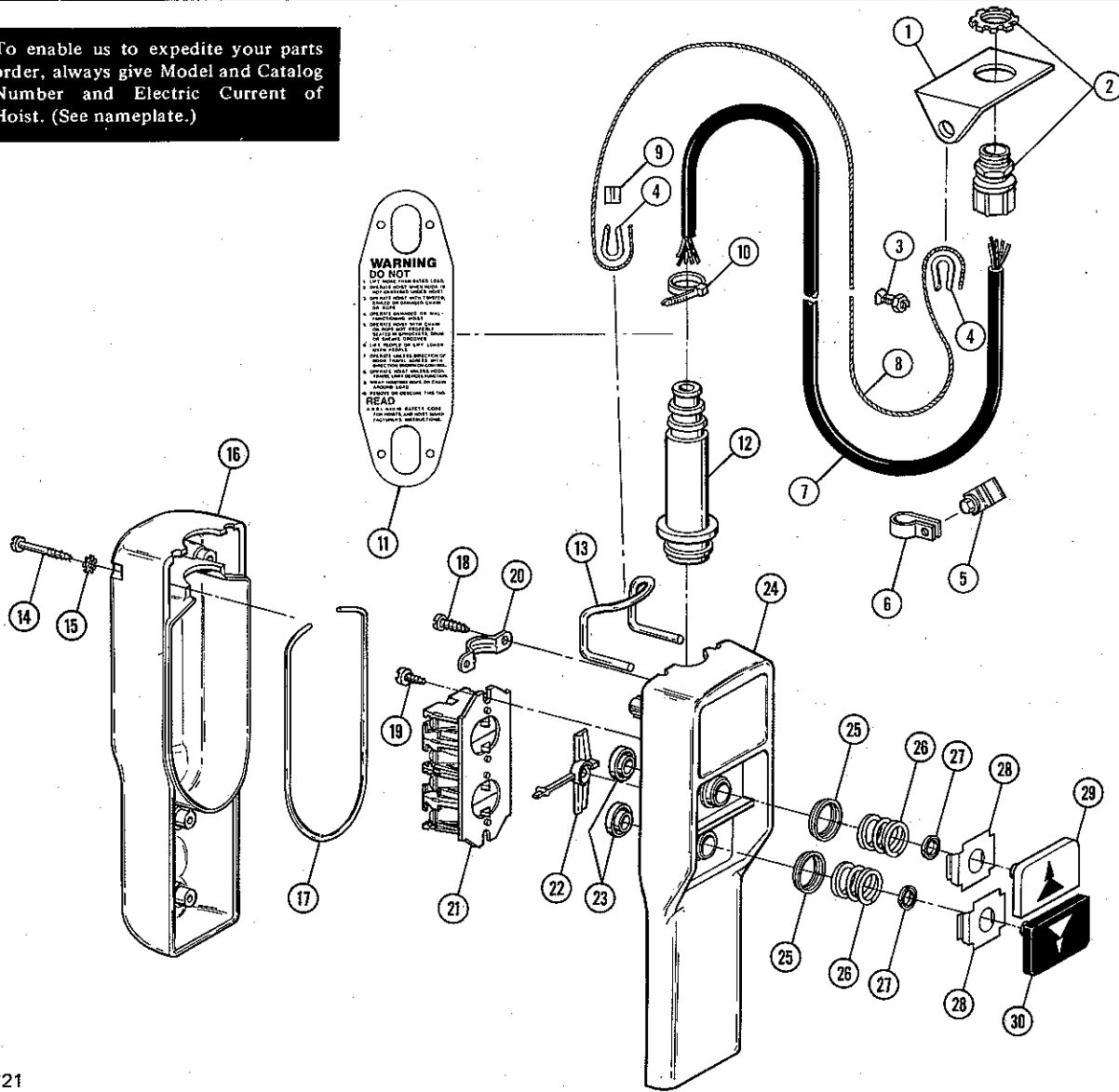

12721

Figure 9-10A. PUSH BUTTON STATION AND CONDUCTOR CABLE ASSEMBLY (Two Speed Hoists Only)

Ref. No.	Part Number	Description	Qty. Req'd.
	BH-1960	Push Button Station and Conductor Cable Assembly (Includes Ref. Nos. 1 thru 30)	1
1	BH-1961	Anchor Bracket - Strain Cable	1
2	BH-1962	Grip Assembly - Conductor	1
3	BH-1963	Connector - Strain Cable	1
4	BH-1964	Thimble - Strain Cable	2
5	BH-1965	Connector - Conductor to Strain Cable	1
6	BH-1966	Clamp - Conductor	1
7	BH-1967	Conductor Cable	1
8	BH-1968	Strain Cable	1
9	BH-1969	Sleeve - Pressure	1
10	BH-1970	Tie - Conductor	As Req'd.
11	BH-1971	Operator Warning Label	1
	BH-1972	Push Button Station (Includes Ref. Nos. 12 thru 30)	1

(Continued on following page.)

To enable us to expedite your parts order, always give Model and Catalog Number and Electric Current of Hoist. (See nameplate.)

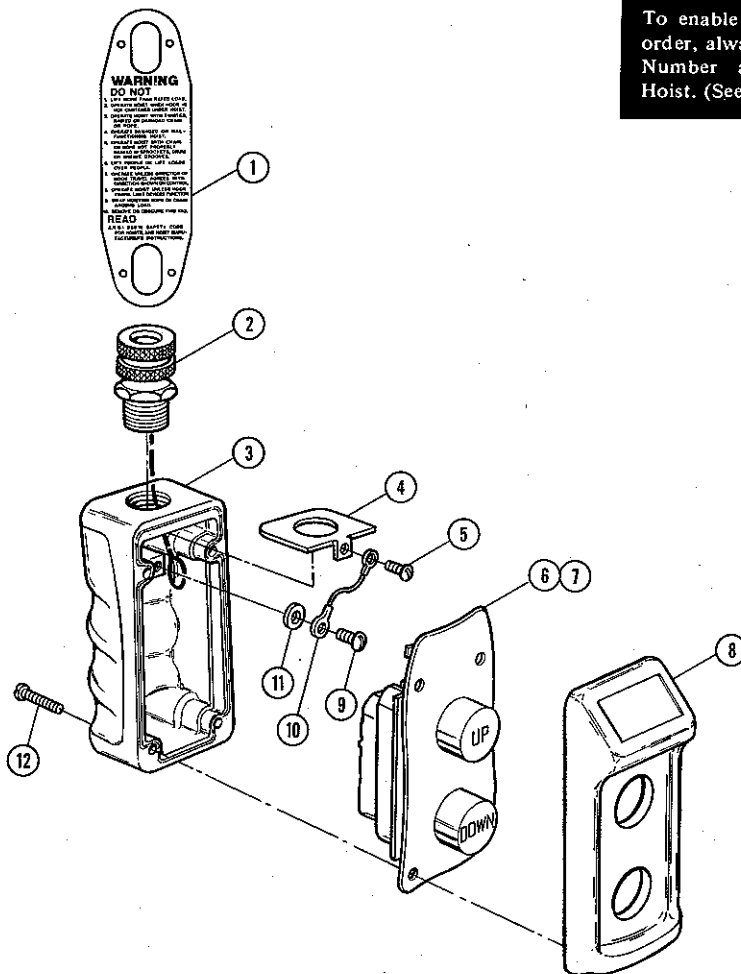

11300A

Figure 9-11. PUSH BUTTON STATION & CONDUCTOR CABLE ASSEMBLY
(Extra Heavy Duty Hoist – Watertight Service)

Ref. No.	Part Number	Description	Qty. Req'd.
*	BH-1939	Push Button Station & Conductor Cable Assembly	1
*	BH-1926	Conductor Cable Assembly (Not Shown)	1
1	BH-1923	Label - Operator Warning (A.N.S.I.)	1
2	BH-1940	Cord Grip	1
	BH-1941	Push Button Station Assembly (Includes Items 3 thru 8 & 12)	1
3	BH-1942	Body - Push Button Station	1
4	BH-1943	Anchor - Cord Grip	1
5	BH-1944	Screw - Grounding	1
6	BH-1945	Interior Assembly Complete	1
7	BH-1946	Gasket - Cover	1
8	BH-1947	Cover - Push Button Station	1
9	BH-1948	Screw - Grounding	1
10	BH-1949	Wire - Jumper	1
11	BH-1950	Washer - Flat	1
12	BH-1951	Screw - Cover	4

* These assemblies are for standard 10' lift hoists. When ordering replacements for hoists with other than standard lifts, specify lift.

To enable us to expedite your parts order, always give Model and Catalog Number and Electric Current of Hoist. (See nameplate.)

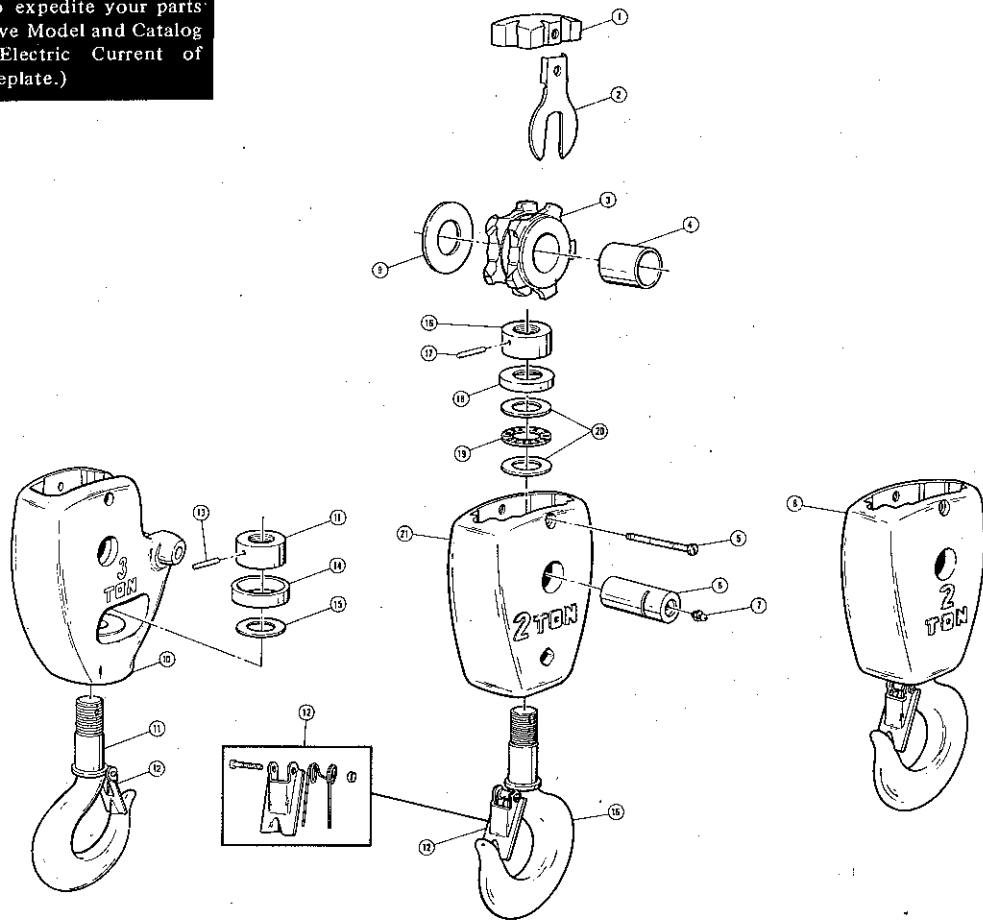

12444

Figure 9-12. 2 & 3 TON LOWER BLOCK ASSEMBLIES (Coil Chain Model Hoists)

Ref. No.	Part Number	Description	Quantity Required	
			2 Ton	3 Ton
	BH-2201	Block Assembly – Lower Complete (Early Model)	1	–
	BH-2219	Block Assembly – Lower Complete	1	–
	BH-2218	Block Assembly – Lower Complete	–	1
1	BH-2202	Guide – Center	1	1
2	BH-2203	Lock – Sprocket Pin	1	1
3	BH-2204	Sprocket – Coil Chain	1	1
4	BH-2205	Bushing – Sprocket	1	1
5	BH-2206	Screw – Fillister Head, Self locking	1	1
6	BH-2207	Pin – Sprocket	1	1
7	BH-2208	Fitting – Hydraulic Drive	1	1
8	BH-2209	Body & Hook Assembly – Lower Block (Early Model)	1	–
9	BH-2210	Washer, Thrust	1	1
10	BH-2211	Body Assembly – Lower Block	–	1
11	BH-2212	Hook/Latch & Nut (Includes Items 12, 13 and 15)	–	1
12	BH-2213	Latch Kit, Hook	1	–
	BH-2214	Latch Kit, Hook	–	1
13	BH-2215	Pin, Grooved	–	1
14	BH-2216	Shroud	–	1
15	BH-2217	Washer, Thrust	–	1
16	BH-2220	Hook/Latch & Nut (Includes Items 12 and 17)	1	–
17	BH-2221	Pin, Grooved	1	–
18	BH-2222	Shield, Bearing	1	–
19	BH-2223	Bearing Assembly – Needle, Thrust	1	–
20	BH-2224	Washer, Thrust	2	–
21	BH-2225	Body – Lower Block	1	–

To enable us to expedite your parts order, always give Model and Catalog Number and Electric Current of Hoist. (See nameplate.)

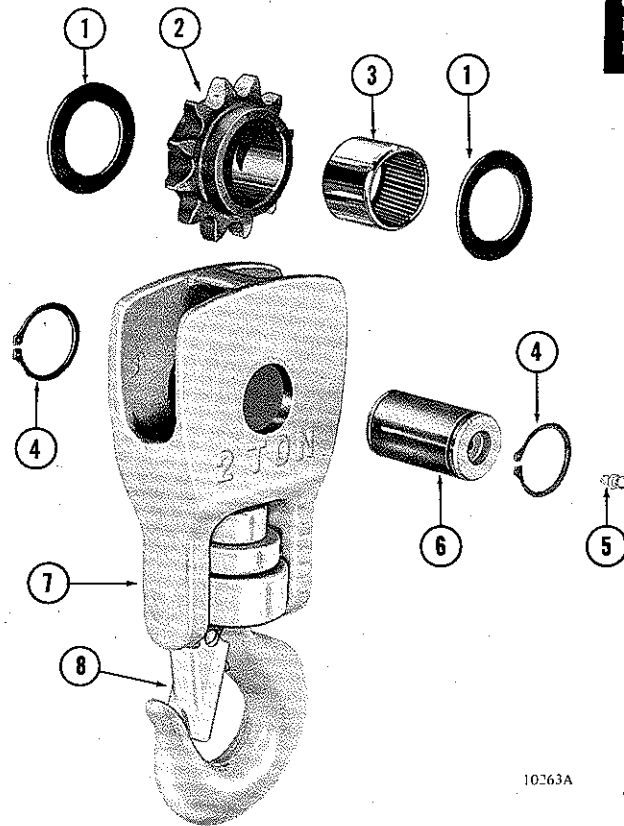

10263A

Figure 9-13. 2 TON LOWER BLOCK ASSEMBLY — (Roller Chain Model Hoists)

Ref. No.	Part Number	Description	Qty. Req'd.
1	BH-2301	Block Assembly — lower, complete	1
2	BH-2302	Washer — Spring Thrust	2
3	BH-2303	Sprocket — Chain	1
4	BH-2304	Bearing Assembly — Needle	1
5	BH-2305	Ring — Retaining, external	2
6	BH-2208	Fitting — Hydraulic Drive	1
7	BH-2307	Pin — Sprocket	1
8	BH-2308	Body and Hook Assembly — Lower Block (Includes Item 8 below)	1
	BH-2213	Latch Kit — Hook	1

NOTICE

Always insist on factory approved **BUDGIT** Hoist replacement parts when servicing this equipment. Parts are available from your local Authorized Repair Station.

To enable us to expedite your parts order, always give Model and Catalog Number and Electric Current of Hoist. (See nameplate.)

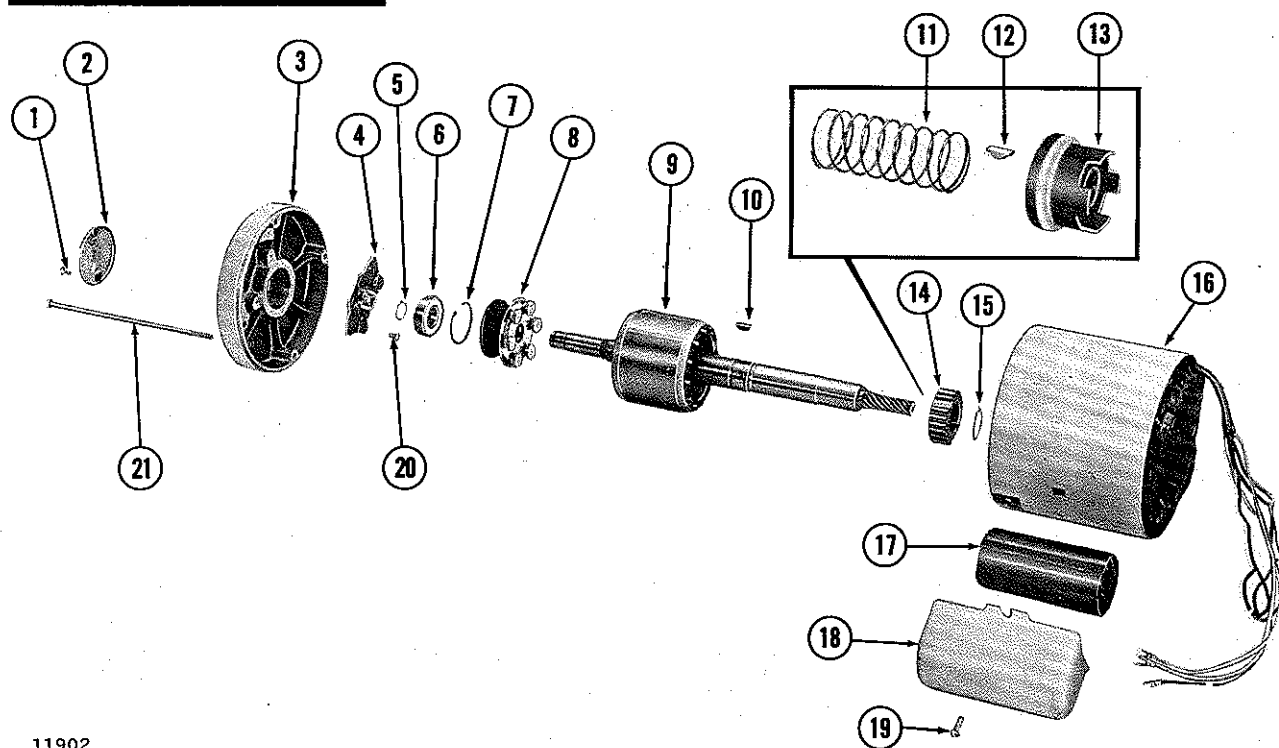

11902

Figure 9-14. SINGLE PHASE MOTOR ASSEMBLIES

Ref. No.	Part Number	Description	Quantity Required		
			1/4 H.P.	1/2 H.P.	1 H.P.
	(See Fig. 9-16)	Motor Assembly - Complete	1	1	-
1	BH-2401	Screw - Round Head Self Tapping	2	2	2
2	BH-2402	Cover - Motor Shaft	1	1	1
3	BH-2405	Bell - End	1	1	1
4	BH-2406	Switch Assembly - Stationary	1	1	1
5	BH-2407	Ring - Retaining, external	2	2	2
6	BH-2408	Bearing Assembly - Ball	1	1	1
7	BH-2409	Ring - Retaining, Internal	1	1	1
8	BH-2410	Switch Assembly - Centrifugal	1	1	1
9	(See Fig. 9-16)	Rotor & Shaft Assembly	1	1	1
10	BH-2411	Key - Woodruff (For Ref. No. 14)	1	1	1
11	BH-2444	Spring - Motor Brake	1	-	-
	BH-2449	Spring - Motor Brake	-	1	-
	BH-2445	Spring - Motor Brake	-	-	1
12	BH-2447	Key - Woodruff - Hi - Pro	1	1	1
13	BH-2446	Plunger, Motor Brake	1	1	1
14	BH-2412	Hub - Motor Brake, splined	1	1	1
15	BH-2413	Ring - Retaining	1	1	1
16	(See Fig. 9-16)	Stator Assembly (Includes Items 6, 16, 17 & 18)	1	1	1
17	BH-2414	Capacitor Assembly - 115 volt	1	-	-
	BH-2415	Capacitor Assembly - 230 volt	1	-	-
	BH-2416	Capacitor Assembly - 115 volt	-	1	-
	BH-2417	Capacitor Assembly - 230 volt	-	1	-
	BH-2418	Capacitor Assembly - 230 volt	-	-	1
18	BH-2419	Cover - Capacitor	1	1	1
	BH-2420	End Cap - Capacitor (Not Shown)	1	1	1
19	BH-2421	Screw - Truss Head Self Tapping	2	2	2
20	BH-2448	Screw - Hex Washer-Head Self Tapping	4	4	4
21	BH-2440	Bolt - Motor Mounting	4	4	-
	BH-2441	Bolt - Motor Mounting	-	-	4

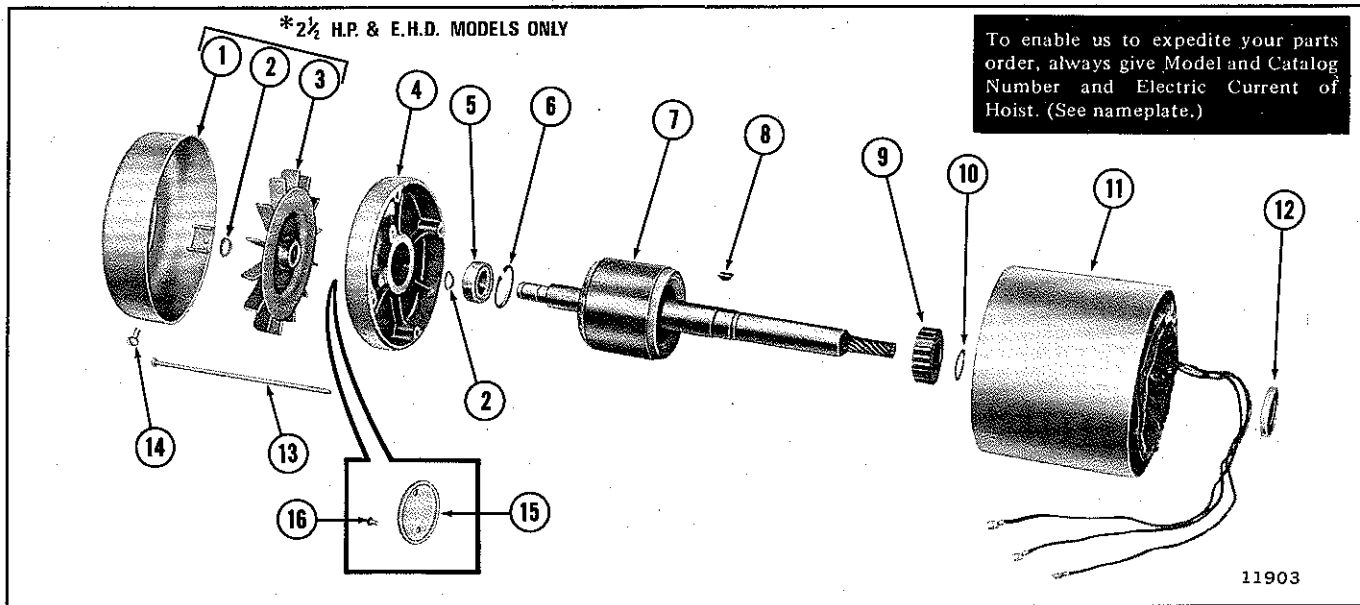

Figure 9-15. THREE PHASE MOTOR ASSEMBLY – SINGLE SPEED

Ref. No.	Part Number	Description	Qty. Req'd.
	(Fig. 9-16&9-17)	Motor Assembly – Complete	1
1*	BH-2504	Guard – Fan	1
2**	BH-2407	Ring – Retaining, external	2
3*	BH-2505	Fan	1
4	BH-2506	Bell – End (With Tapped Holes for Fan Guard)	1
	BH-2405	Bell – End (Without Tapped Holes)	1
5	BH-2507	Bearing Assembly – Ball (2½ H.P. Motors & Extra Heavy Duty Hoist Motors)	1
	BH-2408	Bearing Assembly – Ball (¼, ½ & 1 H.P. Std. Hoist Motors)	1
6	BH-2409	Ring – Retaining, internal	1
7	(Fig. 9-16&9-17)	Rotor & Shaft Assembly	1
8	BH-2411	Key – Woodruff	1
9	BH-2412	Hub – Motor Brake, splined	1
10	BH-2413	Ring – Retaining, external	1
11	(Fig. 9-16&9-17)	Stator Assembly	1
12	BH-2532	Seal – Oil, Motor shaft (¼, ½ & 1 H.P. Extra Heavy Duty Hoist Motors)	1
13	BH-2502	Bolt – Motor Mounting (All ¼, ½ & 1 H.P. Motors)	4
	BH-2442	Bolt – Motor Mounting (2½ H.P. Motors)	4
14*	BH-2533	Screw – Self tapping	3
15	BH-2402	Cover – Motor Shaft (Motors Without Fan)	1
16	BH-2401	Screw – Round Head Self Tapping	2

*Used only on 2½ H.P. motors and ¼, ½ and 1 H.P. extra heavy duty hoist motors.

**Quantity of 1 used on motors without fan.

NOTES

Figure 9-16. REPLACEMENT MOTOR TABLE – STANDARD SINGLE SPEED MODEL HOISTS.
(Includes: Motor Assemblies, Rotor and Shaft Assemblies and Stator Assembly)

Motor H.P.	Hoist Model Used On	A.C. Voltage	Part Number		
			Motor Assembly	Rotor & Shaft Assembly	*** Stator Assembly
1/4	STANDARD MODEL HOISTS	115-1-60 230-1-60 208-3-60 575-3-60 230/460-3-60	BH-2603* BH-2604* BH-2706 BH-2709 BH-2710	BH-2612** BH-2613** BH-2740 BH-2740 BH-2740	BH-2621 BH-2622 BH-2766 BH-2769 BH-2770
1/2	STANDARD MODEL HOISTS	115-1-60 230-1-60 208-3-60 575-3-60 230/460-3-60	BH-2607* BH-2608* BH-2716 BH-2719 BH-2720	BH-2616** BH-2617** BH-2750 BH-2750 BH-2750	BH-2625 BH-2626 BH-2776 BH-2779 BH-2780
1	STANDARD MODEL HOISTS	230-1-60 208-3-60 575-3-60 230/460-3-60	BH-2630* BH-2726 BH-2729 BH-2730	BH-2631** BH-2760 BH-2760 BH-2760	BH-2632 BH-2786 BH-2789 BH-2790
2-1/2	HOISTS WITH 316828 MOTORS	208-3-60 575-3-60 230/460-3-60	BH-2791 BH-2793 BH-2792	BH-2795 BH-2795 BH-2795	BH-2797 BH-2799 BH-2798
2-1/2	HOISTS WITH 115307 MODEL NUMBERS, WITH 316822 MOTORS	208-3-60 575-3-60 230/460-3-60	BH-2801 BH-2802 BH-2803	BH-2804 BH-2804 BH-2804	BH-2805 BH-2806 BH-2807

*Motor Assemblies include brake discs and plates.

**Above single phase rotor and shaft assemblies include the centrifugal switch, brake spring, brake plunger, brake hub, and retaining ring.

***Stator Assemblies for single phase motors include stationary switch, capacitor, capacitor cover and cover mounting screws.

Figure 9-17. REPLACEMENT MOTOR TABLE – EXTRA HEAVY DUTY MODEL HOISTS

Motor H.P.	Hoist Model Used On	A. C. Voltage	Part Number		
			Motor Assembly	Rotor & Shaft Assembly	Stator Assembly
1/4	Extra Heavy Duty Hoist	575-3-60 208-3-60 230/460-3-60	BH-2536 BH-2537 BH-2538	BH-2549 BH-2549 BH-2549	BH-2522 BH-2523 BH-2552
1/2	Extra Heavy Duty Hoist	575-3-60 208-3-60 230/460-3-60	BH-2541 BH-2542 BH-2543	BH-2550 BH-2550 BH-2550	BH-2526 BH-2527 BH-2553
1	Extra Heavy Duty Hoist	575-3-60 208-3-60 230/460-3-60	BH-2546 BH-2547 BH-2548	BH-2551 BH-2551 BH-2551	BH-2530 BH-2531 BH-2554

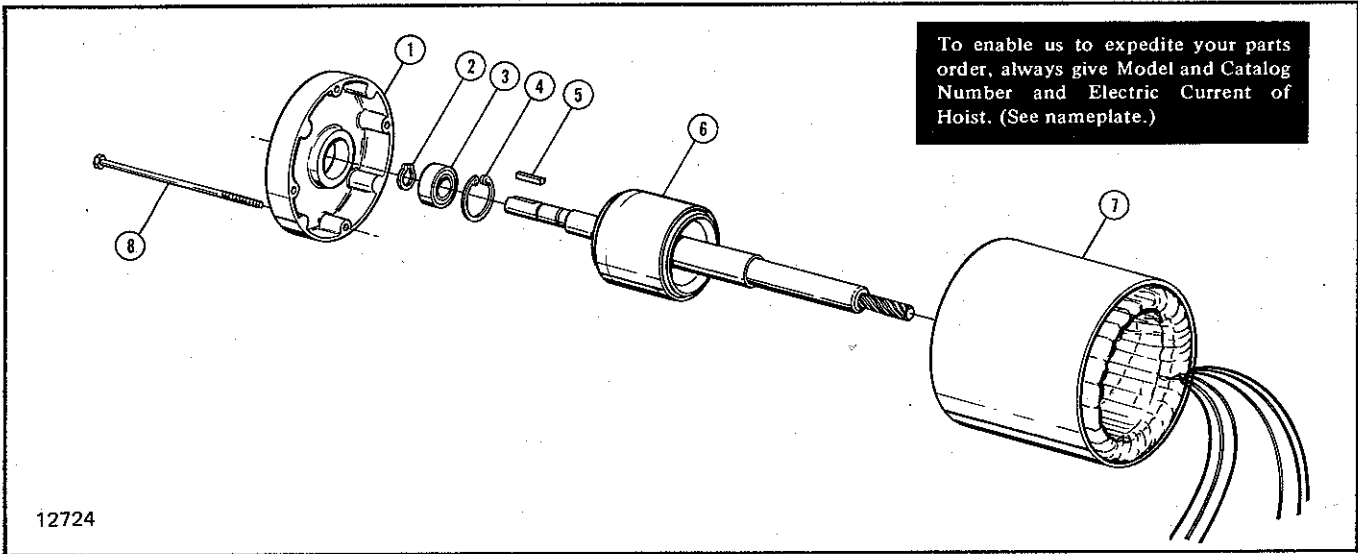
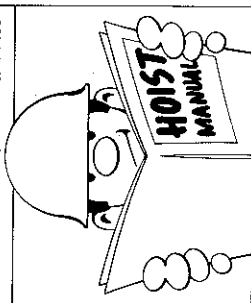

Figure 9-18. THREE PHASE MOTOR ASSEMBLY – TWO SPEED

Ref. No.	Part Number	Description	Qty. Req'd.
		Motor Assembly (Includes Ref. Nos. 1 thru 8)	1
		1/2 - 1/6 Horsepower	
	BH-2901	208 Volt	
	BH-2902	230 Volt	
	BH-2903	460 Volt	
	BH-2904	575 Volt	
		1 - 1/3 Horsepower	
	BH-2905	208 Volt	
	BH-2906	230 Volt	
	BH-2907	460 Volt	
	BH-2908	575 Volt	
		2-1/4 - 3/4 Horsepower	
	BH-2909	208 Volt	
	BH-2910	230 Volt	
	BH-2911	460 Volt	
	BH-2912	575 Volt	
1	BH-2913	Bell - End	1
2	BH-2914	Ring - Retaining	1
3	BH-2915	Bearing - Ball	1
4	BH-2916	Ring - Retaining	1
5	BH-2917	Key - Brake	1
6		Rotor and Shaft Assembly	1
		1/2 - 1/6 Horsepower	
	BH-2918	208 Volt	
	BH-2919	230 Volt	
	BH-2920	460 Volt	
	BH-2921	575 Volt	
		1 - 1/3 Horsepower	
	BH-2922	208 Volt	
	BH-2923	230 Volt	
	BH-2924	460 Volt	
	BH-2925	575 Volt	
		2-1/4 - 3/4 Horsepower	
	BH-2926	208 Volt	
	BH-2927	230 Volt	
	BH-2928	460 Volt	
	BH-2929	575 Volt	

(Continued on following page.)

SAFE IS ... BEING SMART!
STUDY MANUFACTURER'S INSTRUCTION MANUAL. BE A SKILLED HOIST OPERATOR!



WRONG WAY!

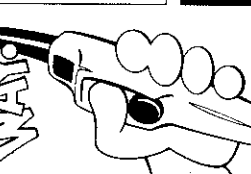

SAFE IS... A CORRECTLY CONNECTED HOIST!

IF A 3-PHASE HOIST "LOWERS" WHEN "UP" CONTROL IS ACTUATED - IMMEDIATELY RECONNECT ANY TWO POWER LEADS AT HOIST POWER SOURCE!

FAILURE TO DO SO WOULD BE DANGEROUS!

SAFE IS ... ALWAYS CENTERING HOIST OVER LOAD BEFORE LIFTING!
EXCESSIVE SIDE PULL CAN DAMAGE HOIST, TROLLEY, OR ROPE (CHAIN)... DON'T SIDE-PULL LOADS!

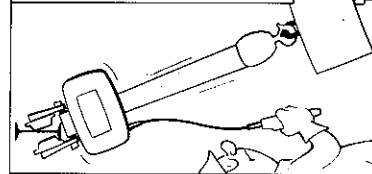

SAFE IS... NEVER TWISTING CHAIN OR ROPE BY CAPSIZING LOWER BLOCK!

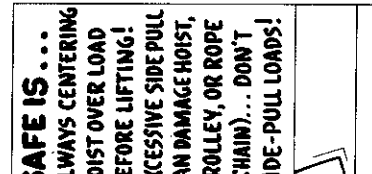

ALSO... NEVER KINK A ROLLER CHAIN!

SAFE IS... ALWAYS CHECKING HOIST BEFORE SHIFT. CHECK HOOKS, LOAD CHAIN (ROPE), LIMIT SWITCHES & BRAKES. - MAKE CERTAIN OF THEIR CONDITION!

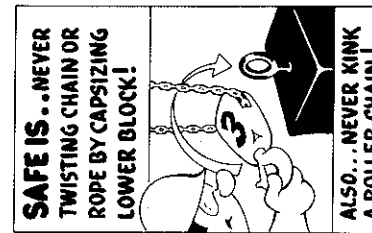

SAFE IS... NEVER USING HOIST AS A SLING. ALWAYS USE APPROVED SLING!

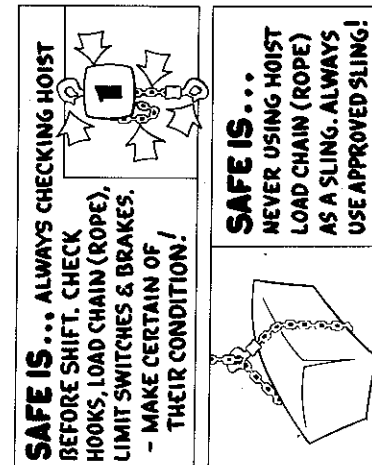

SAFE IS... NEVER OVERLOADING A HOIST!
USE PROPER CAPACITY HOIST TO FIT THE JOB. IN DOUBTFUL WEIGHT SITUATIONS HOISTS WITH OVERLOAD PROTECTION DEVICES WILL REJECT DANGEROUS OVERLOADS ... USE THEM!
CAUTION: BE SURE OVERHEAD SUSPENSION WILL HOLD THE LOAD!

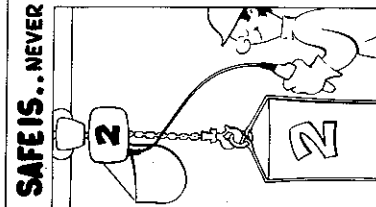

SAFE IS... NOT OPERATING A HOIST TO EXTREME LIMITS OF THE ROPE (CHAIN)!

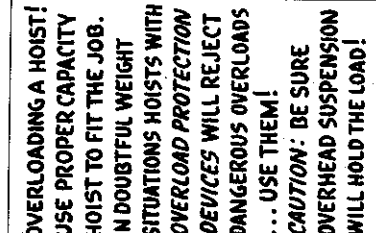

LIMIT SWITCHES ARE ONLY FOR EMERGENCY STOPS!

SAFE IS... MAKING SURE NEVER LEAVING LOADS SUSPENDED IN AIR UNATTENDED!



SAFE IS... USING A CHAIN CONTAINER ON ELECTRIC CHAIN HOIST WHERE NEEDED!

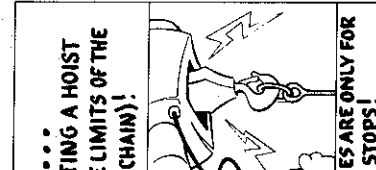

SAFE IS... NEVER BANGING HOIST INTO OTHER HOISTS OR OBJECTS!

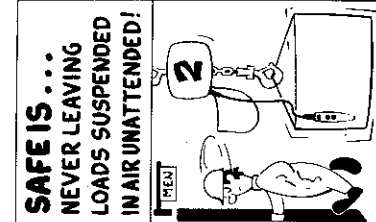

SAFE IS... NEVER TRAVELING LOADS OVER PEOPLE!

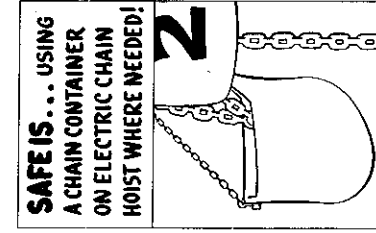

SAFE IS... ALSO

- USING COMMON SENSE IN TRAVELING LOADS! WATCH WHERE YOU'RE GOING!
- BEING SURE THAT LOAD SLING IS PROPERLY SEATED IN SADDLE OF HOOK WITH LATCH CLOSED!
- BEING A THOUGHTFUL AND COURTEOUS HOIST OPERATOR!

Safe is Beautiful!

SAFE IS... CAREFULLY TAKING UP SLACK IN LOAD CHAIN (ROPE). NEVER APPLY SHOCK LOADS!

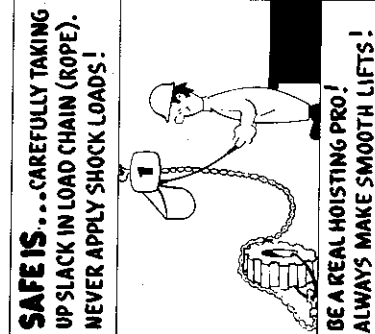

BE A REAL HOISTING PRO! ALWAYS MAKE SMOOTH LIFTS!

SAFE IS... NEVER OPERATING A HOIST BEYOND ITS DESIGNED DUTY CYCLE!

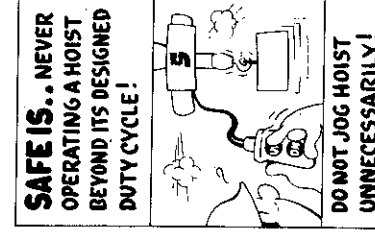

DO NOT JOG HOIST UNNECESSARILY!

SAFE IS... MAKING SURE LOAD IS FREE TO MOVE IN UNOBSTRUCTED AREA!

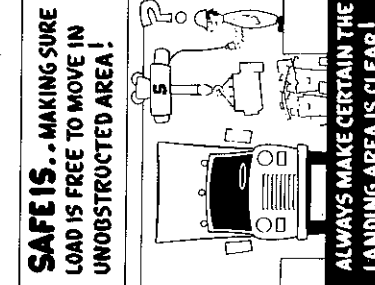

ALWAYS MAKE CERTAIN THE LANDING AREA IS CLEAR!

SAFE IS... MAKING SURE LOAD IS EVENLY BALANCED AND SECURE IN LOAD SLING!



DON'T TAKE CHANCES!

SAFE IS... ALSO

- USING COMMON SENSE IN TRAVELING LOADS! WATCH WHERE YOU'RE GOING!
- BEING SURE THAT LOAD SLING IS PROPERLY SEATED IN SADDLE OF HOOK WITH LATCH CLOSED!
- BEING A THOUGHTFUL AND COURTEOUS HOIST OPERATOR!

Safe is Beautiful!

**Recommended Spare Parts
for Your BUDGIT Hoist**

Certain parts of your hoist will, in time, require replacement under normal wear conditions. It is suggested that the following parts be purchased for your hoist as spares for future use.

Set of Gaskets

Set of Bearings

Set of Oil Seals

Lower Block Assembly

Load Chain

Set of Brake Discs for Load Brake

Set of Brake Discs for Motor Brake

Push Button Station & Cable Assembly

Transformer

Solenoid for Contactor (Two)

Transformer Fuse

Limit Lever

Limit Switch Assembly

Stator

NOTE: When ordering parts always furnish Model and Catalog Number of Hoist and lift of hoist on which the parts are to be used.

Parts for your hoist are available from your local authorized BUDGIT/TUGIT repair station. For the location of your nearest repair station, write:

**Crane & Hoist Division
Dresser Industries, Inc.
P.O. Box 769
Muskegon, Michigan 49443**

or phone:

616/733-0821

WARRANTY

WARRANTY AND LIMITATION OF LIABILITY

A. Seller warrants that its products and parts, when shipped, and its work (including installation, construction and start-up), when performed, will meet applicable specifications, will be of good quality and will be free from defects in material and workmanship. All claims for defective products or parts under this warranty must be made in writing immediately upon discovery and, in any event, within one (1) year from shipment of the applicable item unless Seller specifically assumes installation, construction or start-up responsibility. All claims for defective products or parts when Seller specifically assumes installation, construction or start-up responsibility, and all claims for defective work must be made in writing immediately upon discovery and, in any event, within one (1) year from completion of the applicable work by Seller, provided, however, all claims for defective products and parts must be made in writing no later than eighteen (18) months after shipment. Defective items must be held for Seller's inspection and returned to the original f.o.b. point upon request. THE FOREGOING IS EXPRESSLY IN LIEU OF ALL OTHER WARRANTIES WHATSOEVER, EXPRESS, IMPLIED AND STATUTORY, INCLUDING, WITHOUT LIMITATION, THE IMPLIED WARRANTIES OF MERCHANTABILITY AND FITNESS.

B. Upon Buyer's submission of a claim as provided above and its substantiation, Seller shall at its option either (i) repair or replace its product, part or work at either the original f.o.b. point of delivery or at Seller's authorized service station nearest Buyer or (ii) refund an equitable portion of the purchase price.

C. This warranty is contingent upon Buyer's proper maintenance and care of Seller's products, and does not extend to fair wear and tear. Seller reserves the right to void warranty in event of Buyer's use of inappropriate materials in the course of repair or maintenance, or if Seller's products have been dismantled prior to submission to Seller for warranty inspection.

D. The foregoing is Seller's only obligation and Buyer's exclusive remedy for breach of warranty, and is Buyer's exclusive remedy hereunder by way of breach of contract, tort, strict liability or otherwise. In no event shall Buyer be entitled to or Seller liable for incidental or consequential damages. Any action for breach of this agreement must be commenced within one (1) year after the cause of action has accrued.

BUDGIT 

**CRANE & HOIST DIVISION • DRESSER INDUSTRIES, INC.
MUSKEGON, MICHIGAN 49443**