

DOL 53

Ammonia sensor



For other language variants of this document we refer to www.dol-sensors.com or your local dealer.

1 Product description

The DOL 53 is an electrochemical sensor designed to measure ammonia levels in livestock houses. The sensor consists of a sensor element, a house, and a dust filter. The sensor element (sensor head) and filter can be replaced as required, and the sensor element is supplied in a can for additional protection. Cable is included.

The sensor is meant for stationary mounting to measure the ammonia concentration continuously.

2 Product survey



140247 DOL 53 Ammonia sensor

DOL 53 measures the ammonia in the house's air.

Can be used for monitoring the ammonia level in the air.



140248 DOL 53 Replacement sensor head

Sensor element for DOL 53.



140236 DOL 53 dust filter (5 pcs.)

Dust filters for DOL 51 and DOL 53. Set of 5 pieces.



140238 DOL 53 protection against water

Kit for protection against water spray for DOL 53.



140284 DOL 53 cable with connector (2 m)

2 meter wire with plug for DOL 53.



140299 DOL 53 – test gas adapter

Used for gas test of DOL 51 and DOL 53.

3 Installation

Mount the sensor in the mounting lug at the top of the sensor, filter facing down. The offset from vertical must be max. 15° (see the illustration). DOL 53 must be mounted so that it is accessible in connection with maintenance and must not be subjected to splash water.

Ensure free air passage around the sensor filter. Do not expose it to direct sunlight as this will affect the measurements.

DOL 53 must warm up for half an hour before being ready to measure (see the section of LED indication).

The sensor must be placed in middle of the livestock house or in the center between walls/filters when used in an air cleaner. Make sure there is an adequate distance to walls and air inlets.



DOL 53 must not be suspended from the electric cable.

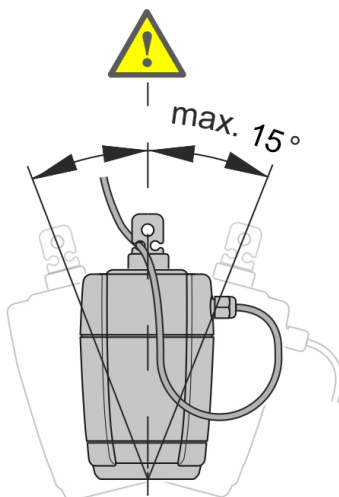

Figure 1: DOL 53 must be mounted vertically with the sensor pointing down; +/- 15° at a location with low vibration and, as far as possible, stable temperatures.

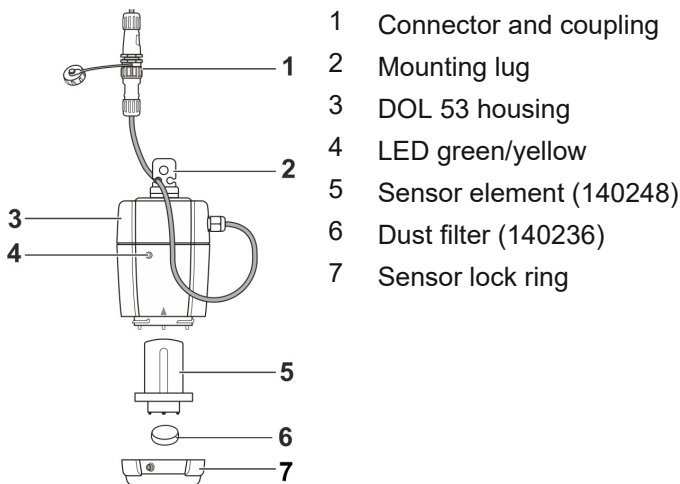

Figure 2: DOL 53.

4 Connection



Installation, servicing and troubleshooting of all electrical equipment must be carried out by qualified personnel in compliance with the applicable national and international standard EN 60204-1 and any other EU standards that are applicable in Europe.

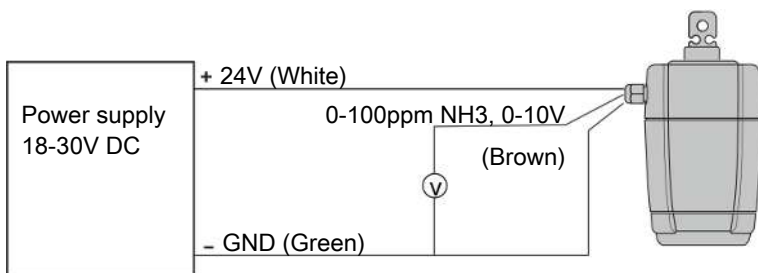

Figure 3: Connections.

Name	Wire color	Pin	Connector
24V supply voltage	White	1	
0-100ppm NH3	Brown	2	
GND	Green	3	
N/A	N/A	4	

5 Functionality

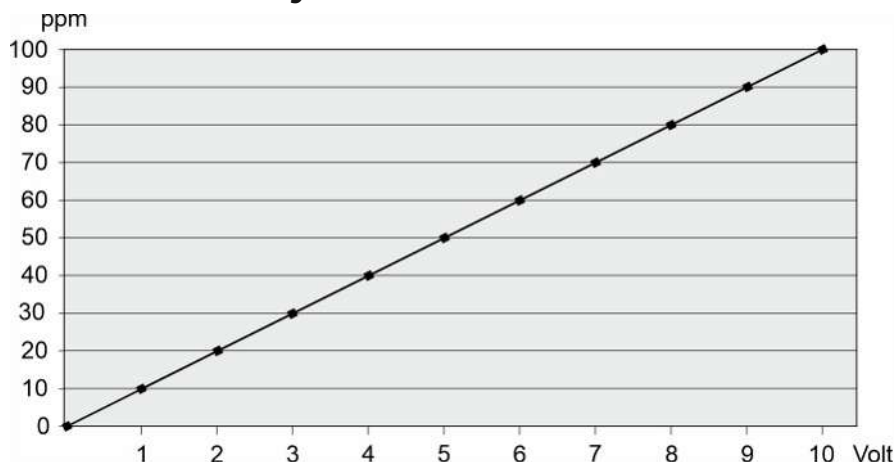









Figure 4: Functional graph.

6 LED indication

LED indication	Sensor status	Action
 YELLOW flashing slowly	Incorrect electrical supply or interrupted supply.	Check installation for cable break. Check the power supply unit of the control unit. Check electric voltage in the junction box or at the sensor element with a multi-meter.
	Short circuit in supply cable.	Check installation for short circuit.
	Overtoltage or undervoltage at the sensor.	Check electric supply voltage at the sensor with a multi-meter.
	Incorrect voltage (e.g. 230 V AC) applied, electronics damaged.	Replace the DOL 53 housing.
	DOL 53 housing is defective.	Replace the DOL 53 housing, contact the supplier.
 Alternating GREEN and YELLOW	Sensor is warming up to be ready for measurements, signal level 0 V.	No activity. Flashing stops after max. 30 minutes.
 Constant GREEN	Normal operation.	
 GREEN flashing quickly	The concentration of ammonia is between 40-60ppm which is used for testing the sensor. The sensor is working but it thinks it is in test mode.	No activity. Flashing stops after max. 5 minutes.
 Constant YELLOW	Internal fault detected by electronics, signal level 0 V.	Replace the DOL 53 housing.
 YELLOW flashing	There is very little ammonia in the livestock house - under -5ppm, the sensor output is 0V.	Replace the sensor element, if the fault continues for more than one day.
 GREEN flashing	Concentration measurement is above 105ppm outside the measuring range.	Ventilate with fresh air.

LED indication	Sensor status	Action
 GREEN/GREEN/ GREEN/YELLOW	Age monitoring, sensor element is older than 3 years, service life is expired, see date on sensor element type plate.	Replace the sensor element.

7 Trouble shooting instructions

Error	Cause	Action
Packaging is damaged.	Damage in transit.	Contact the supplier in case the sensor element is damaged.
No measurement on the control unit.	Electrical connection faulty or interrupted.	Check installation for cable break.
	DOL 53 aligned incorrectly, not vertical.	Install the sensor in accordance with mounting instructions, vertical +/- 15°.
	Sensor element is faulty or used up.	Replace the sensor element.
	DOL 53 housing is defective.	Replace the DOL 53 house.
Incorrect measurement on the control unit.	The dust filter is clogged.	Replace the dust filter. Check the sensitivity with test gas.
Unexpected measurement on the control unit.	Brief interference pulses <5 seconds.	Interference caused by electrical equipment, e.g. lighting, fans or heaters. Identify device and suppress interference.
Unstable measured value.	Dynamic signal fluctuations with a period of more than 5 seconds can arise from turbulence with fresh air.	No activity, continue to monitor.
Wet sensor.	DOL 53 was cleaned with water.	Wipe DOL 53 dry.
	Condensation.	
Black fluid is leaking from the sensor element.	The sensor element is defective.	Replace the sensor element.

8 Maintenance

The sensor element must be replaced after 3 years of operation at the latest, see date on the sensor element type plate.

Carry out the daily visual inspection to detect operation readiness.

Have specialists carry out the annual inspection and sensitivity check.



Replace the dust filter in front of the sensor element, if clogged. A clogged filter prolongs the response time of the sensor element. This affects the sensitivity. The dust filter must always be replaced prior to checking the sensitivity.



DOL 53 must be removed during cleaning and disinfection. After removing the connector, screw on the sealing plug. A missing sealing plug leads to corrosion of the connector.

Cleaning

Clean the sensor surface with lukewarm water. Check for mechanical damage.

Transport



The sensor must be transported in the original packing in air traffic. Otherwise the sensor may lose its measuring sensitivity.

9 Technical data

		DOL 53, 0-10V, 0-100 ppm NH₃	
Specification		Parameter	Unit
Output	Voltage range	0 - 10	VDC
NH ₃	Measuring range	0 - 100	ppm NH ₃
	Voltage resolution	0.1	V/ppm NH ₃
	Signal transmission resolution	0.5	ppm NH ₃
	Accuracy	1.5 ppm or $\pm 10\%$ of the measured value	ppm NH ₃
	Long term drift	$< \pm 10\%$ of the measured value	%
	Time constant: T50	≤ 30	sec.
Supply voltage		18 – 30	VDC
Supply current		< 10	mA
Temperature, operation		0 - +50	°C
Temperature, storage		-20 - +60	°C
Humidity		15 - 95	%RH
Pressure		700 - 1300	hPa
Max. storage time (sensor element)	See date on sensor can		
Warranty sensor element		2	years
Expected lifetime of sensor element	Not beyond the date on the sensor element type plate	3	years
IP classification		IP65 (DIN 40050-9)	
Cable length		2	m
Cable conductor size		3 x 0.25 (3 x AWG23)	mm ²
Max. cable length at 0.75 mm ²		100	m
Max. cable length at 1.5 mm ²		200	m
Dimensions (diameter/width)		75	mm
Dimensions (length)		155	mm
Weight		500	g
Approvals		CE UKCA	

9.1 Dimensioned sketch

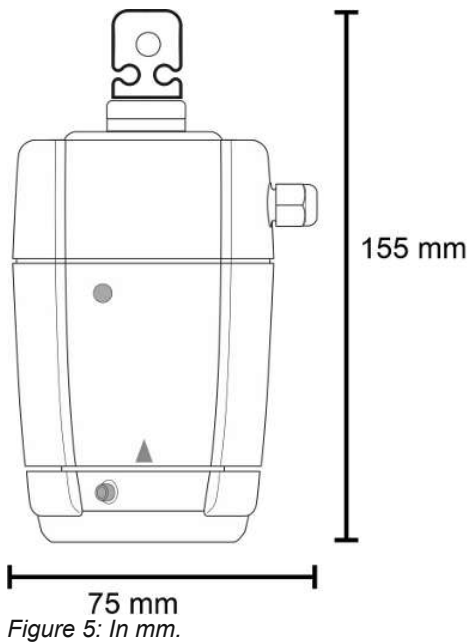

Figure 5: In mm.