

SDM-6RO

Expansion Module – 6 relay outputs

Version 1.1

User Manual



Manufactured for



Thank you for choosing our product.

This manual will help you with proper support and proper operation of the device.

The information contained in this manual have been prepared with utmost care by our professionals and serve as a description of the product without incurring any liability for the purposes of commercial law.

This information does not release you from the obligation of own judgement and verification.

We reserve the right to change product specifications without notice.

Please read the instructions carefully and follow the recommendations contained therein.



WARNING!

Failure to follow instructions can result in equipment damage or impede the use of the hardware or software.

1. Safety rules

- Before first use, refer to this manual
- Before first use, make sure that all cables are connected properly
- Please ensure proper working conditions, according to the device specifications (eg: supply voltage, temperature, maximum power consumption)
- Before making any modifications to wiring connections, turn off the power supply

2. Module Features

2.1. Purpose and description of the module

The SDM-6RO module is an innovative device that provides a simple and cost-effective extension of the number of lines of output with high current-carrying capacity.

The module has 6 relay outputs. Each relay has three terminals: common (COM), normally open (NO) or normally closed (NC), so that the unit is very flexible.

This module is connected to the RS485 bus with twisted-pair wire. Communication is via MODBUS RTU or MODBUS ASCII. The use of 32-bit ARM core processor provides fast processing and quick communication. The baud rate is configurable from 2400 to 115200.

The module is designed for mounting on a DIN rail in accordance with DIN EN 5002.

The module is equipped with a set of LEDs used to indicate the status of inputs and outputs useful for diagnostic purposes and helping to find errors.

Module configuration is done via USB by using a dedicated computer program. You can also change the parameters using the MODBUS protocol.

2.2. Technical Specifications

Power Supply	Voltage	10-30 VDC; 10-28VAC
	Maximum Current*	DC: 200 mA @ 24VDC AC: 250 mA @ 24VAC
	Maximum power consumption	DC: 4.8W; AC: 6VA
Relay outputs	No of outputs	6
	The maximum current and voltage (resistive load)	5A 250V AC 10A 24V DC
Temperature	Work	-10 °C - +50°C
	Storage	-40 °C - +85°C
Connectors	Power Supply	2 pins
	Communication	3 pins
	Outputs	2x 10 pins
	Configuration	Mini USB
Size	Height	110 mm
	Length	62 mm
	Width	88 mm
Interface	RS485	Up to 128 devices

* Maximum current with active Modbus transmission, all outputs on

2.3. Dimensions of the product

Look and dimensions of the module are shown below. The module is mounted directly to the rail in the DIN industry standard. Power connectors, communication and IOs are at the bottom and top of the module. USB connector configuration and indicators located on the front of the module.

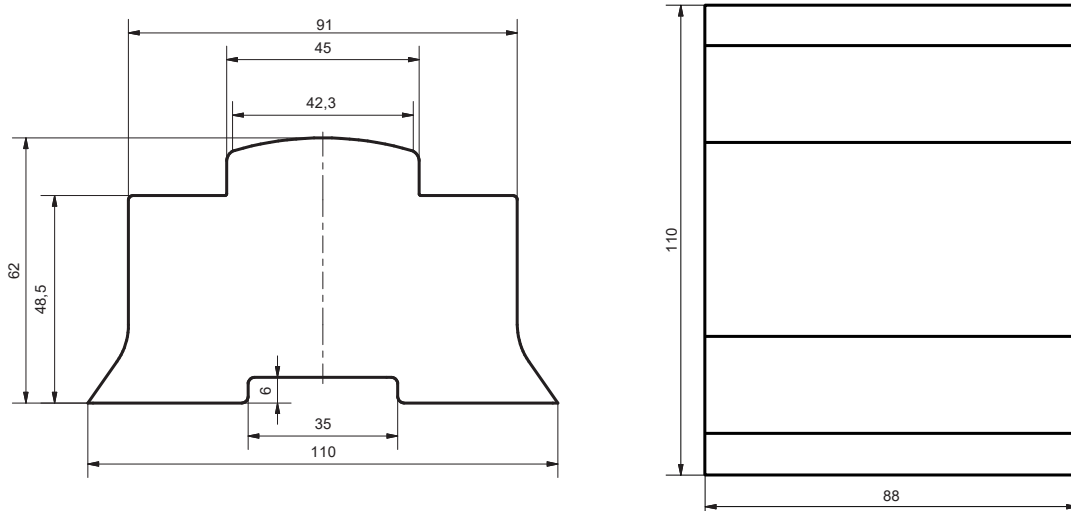

3. Communication configuration

3.1. Grounding and shielding

In most cases, IO modules will be installed in an enclosure along with other devices which generate electromagnetic radiation. Examples of these devices are relays and contactors, transformers, motor controllers etc. This electromagnetic radiation can induce electrical noise into both power and signal lines, as well as direct radiation into the module causing negative effects on the system. Appropriate grounding, shielding and other protective steps should be taken at the installation stage to prevent these effects. These protective steps include control cabinet grounding, module grounding, cable shield grounding, protective elements for electromagnetic switching devices, correct wiring as well as consideration of cable types and their cross sections.

3.2. Network Termination

Transmission line effects often present a problem on data communication networks. These problems include reflections and signal attenuation.

To eliminate the presence of reflections from the end of the cable, the cable must be terminated at both ends with a resistor across the line equal to its characteristic impedance. Both ends must be terminated since the direction of propagation is bi-directional. In the case of an RS485 twisted pair cable this termination is typically 120 Ω.

3.3. Setting Module Address in RS485 Modbus Network

The following table shows how to set switch to determine the address of the module. The module address is set with the switches in the range of 0 to 127. Addresses From 128 to 255 can be set via RS485 or USB.

Switch	Address
SW1	+1
SW2	+2
SW3	+4
SW4	+8
SW5	+16
SW6	+32
SW7	+64

Ex. if switches 1, 3 and 5 are on then module address is:

$$\text{Address} = 1 + 4 + 16 = 21$$

3.4. Types of Modbus Registers

There are 4 types of variables available in the module.

Type	Beginning address	Variable	Access	Modbus Command
1	00001	Digital Outputs	Bit Read & Write	1, 5, 15
2	10001	Digital Inputs	Bit Read	2
3	30001	Input Registers	Registered Read	3
4	40001	Output Registers	Registered Read & Write	4, 6, 16

3.5. Communication settings

You can restore the default configuration by the switch SW8 (see 3.5.2 - Restore the default configuration)

3.5.1. Default settings

You can restore the default configuration by the switch SW8 (see 3.5.2 - Restore the default configuration)

Boud rate	19200
Pariti	Nie
Data bits	8
Stop bits	1
Reply Delay [ms]	0
Modbus Type	RTU

3.5.2. Restore the default configuration

To restore the default configuration:

- turn off the power
- turn on the switch SW8
- turn on the power
- when power and communication LED start blinking alternately than turn off the switch SW8

Caution! After restoring the default configuration all values stored in the registers will be cleared as well.

3.5.3. Configuration registers

Modbus	Dec	Hex	Name	Values
40003	2	0x02	Baud rate	0 – 2400 1 – 4800 2 – 9600 3 – 19200 4 – 38400 5 – 57600 6 – 115200 other – value * 10
40005	4	0x04	Parity	0 – none 1 – odd 2 – even 3 – always 1 4 – always 0
40004	3	0x03	Stop Bits LSB	1 – one stop bit 2 – two stop bit
40004	3	0x03	Data Bits MSB	7 – 7 data bits 8 – 8 data bits
40006	5	0x05	Response delay	Time in ms
40007	6	0x06	Modbus Mode	0 – RTU 1 – ASCII

4. Switches

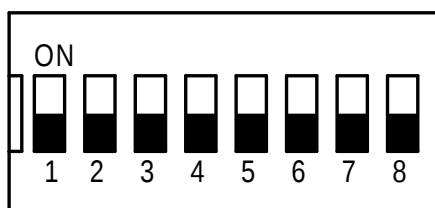

Switch	Function	Description
1	Module address +1	Setting module address from 0 to 127
2	Module address +2	
3	Module address +4	
4	Module address +8	
5	Module address +16	
6	Module address +32	
7	Module address +64	
8	Restoring default settings	Restoring default settings (see 3.5.1 - Default settings i 3.5.2 - Restore the default configuration).

5. Front panel removing

To remove the panel and gain access to the switch, you must pry open the panel using a thin tool (eg a small screwdriver) as in the picture below.



6. Indicators

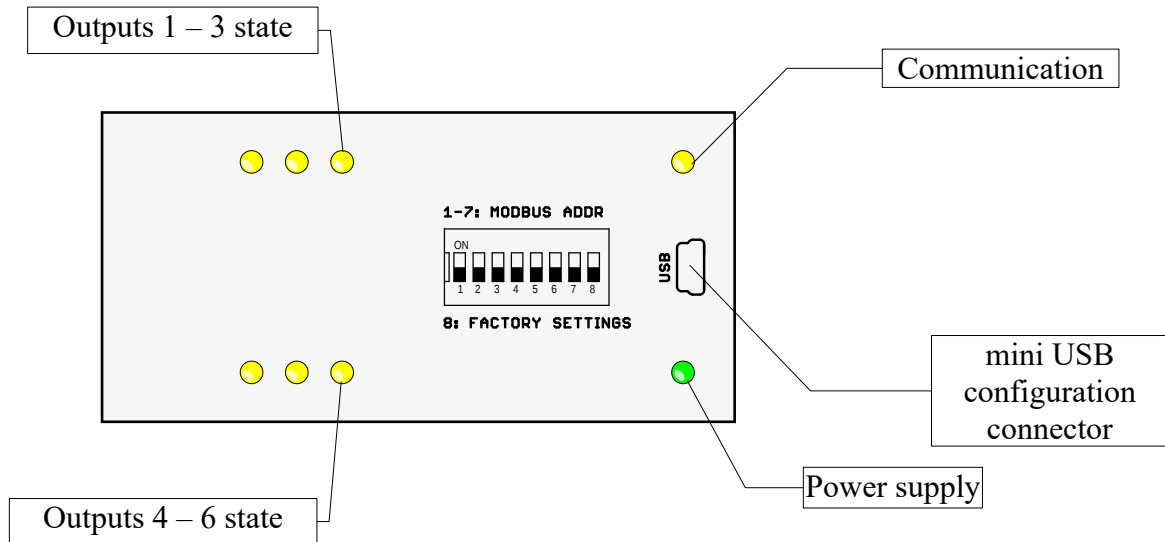

Indicators	Description
Power supply	LED indicates that the module is correctly powered.
Communication	The LED lights up when the unit received the correct packet and sends the answer.
Outputs state	LED indicates that the output is on.

7. Module Connection

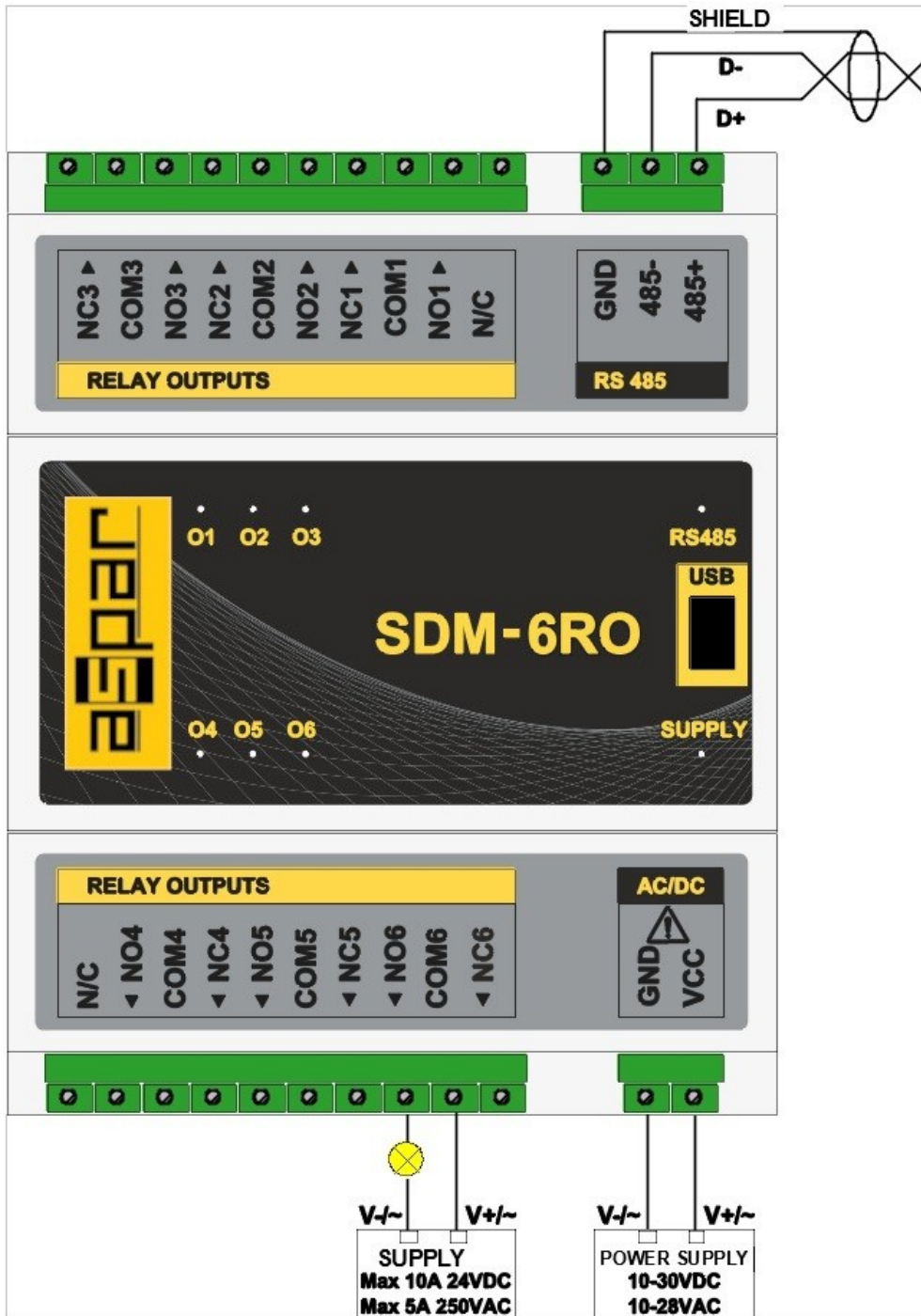

8. Modules Registers

8.1. Registered access

Modbus	Dec	Hex	Register Name	Access	Description
30001	0	0x00	Version/Type	Read	Version and Type of the device
30002	1	0x01	Switches	Read	Switches state
40003	2	0x02	Baud rate	Read & Write	RS485 baud rate
40004	3	0x03	Stop Bits & Data Bits	Read & Write	No of Stop bits & Data Bits
40005	4	0x04	Parity	Read & Write	Parity bit
40006	5	0x05	Response Delay	Read & Write	Response delay in ms
40007	6	0x06	Modbus Mode	Read & Write	Modbus Mode (ASCII or RTU)
40009	8	0x08	Watchdog	Read & Write	Watchdog
40013	12	0x0C	Default Output State	Read & Write	Default output state (after power on or watchdog reset)
40033	32	0x20	Received packets LSB	Read & Write	No of received packets
40034	33	0x21	Received packets MSB	Read & Write	
40035	34	0x22	Incorrect packets LSB	Read & Write	No of received packets with error
40036	35	0x23	Incorrect packets MSB	Read & Write	
40037	36	0x24	Sent packets LSB	Read & Write	No of sent packets
40038	37	0x25	Sent packets MSB	Read & Write	
40052	51	0x33	Outputs	Read & Write	Output state

8.2. Bit access

Modbus Address	Dec Address	Hex Address	Register name	Access	Description
193	192	0x0C0	Default state of output 1	Read & Write	Default state of output 1
194	193	0x0C1	Default state of output 2	Read & Write	Default state of output 2
195	194	0x0C2	Default state of output 3	Read & Write	Default state of output 3
196	195	0x0C3	Default state of output 4	Read & Write	Default state of output 4
197	196	0x0C4	Default state of output 5	Read & Write	Default state of output 5
198	197	0x0C5	Default state of output 6	Read & Write	Default state of output 6
817	816	0x330	Output 1	Read & Write	Output 1 state
818	817	0x331	Output 2	Read & Write	Output 2 state
819	818	0x332	Output 3	Read & Write	Output 3 state
820	819	0x333	Output 4	Read & Write	Output 4 state
821	820	0x334	Output 5	Read & Write	Output 5 state
822	821	0x335	Output 6	Read & Write	Output 6 state

9. Configuration software

Modbus Configurator is software that is designed to set the module registers responsible for communication over Modbus network as well as to read and write the current value of other registers of the module. This program can be a convenient way to test the system as well as to observe real-time changes in the registers.

Communication with the module is done via the USB cable. The module does not require any drivers.

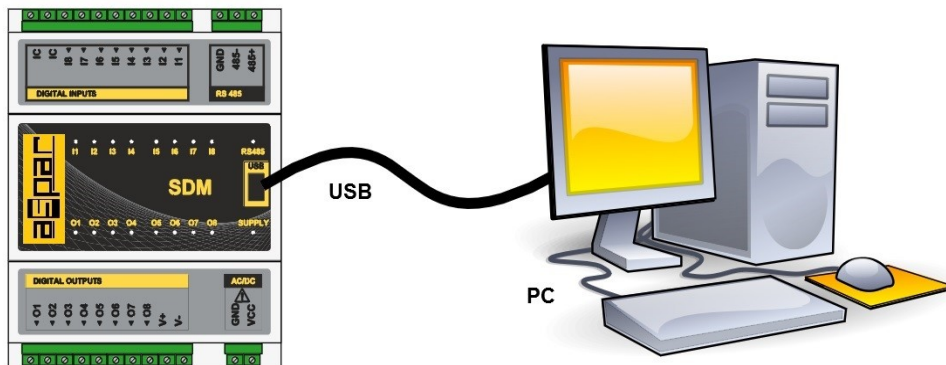

Communication with the module is done via the USB cable. The module does not require any drivers.

Configurator is a universal program, whereby it is possible to configure all available modules.

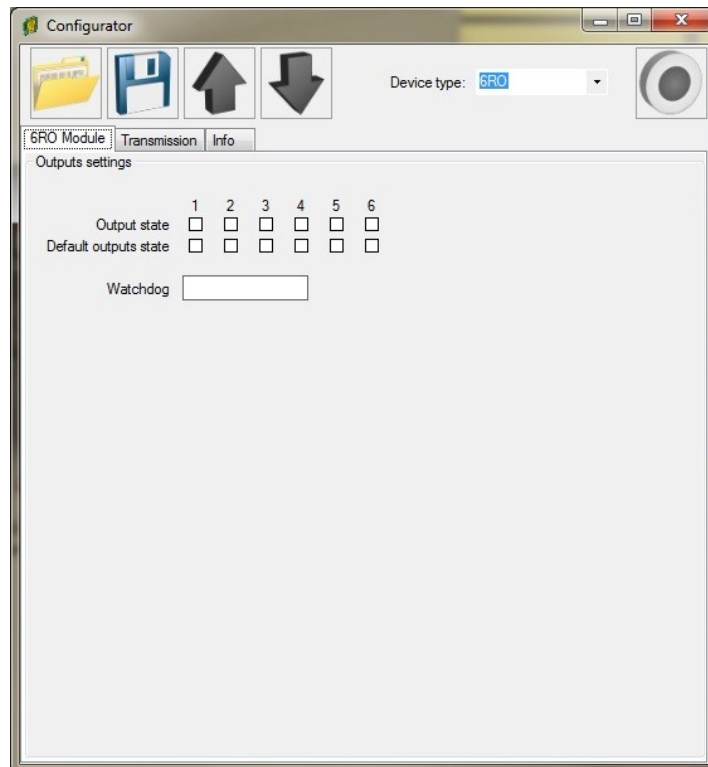

Table of content

1. Safety rules.....	3
2. Module Features.....	3
2.1. Purpose and description of the module.....	3
2.2. Technical Specifications.....	4
2.3. Dimensions of the product.....	5
3. Communication configuration.....	6
3.1. Grounding and shielding.....	6
3.2. Network Termination.....	6
3.3. Setting Module Address in RS485 Modbus Network.....	6
3.4. Types of Modbus Registers.....	7
3.5. Communication settings.....	7
3.5.1. Default settings.....	7
3.5.2. Restore the default configuration.....	7
3.5.3. Configuration registers.....	8
4. Switches.....	9
5. Front panel removing.....	10
6. Indicators.....	11
7. Module Connection.....	12
8. Modules Registers.....	13
8.1. Registered access.....	13
8.2. Bit access.....	14
9. Configuration software.....	15



Manufactured for:
Aspar s.c.
ul. Kapitańska 9
81-331 Gdynia
POLAND

ampero@ampero.eu
www.ampero.eu

tel. +48 58 351 39 89; +48 58 732 71 73

