

FREEDOM FR001 & FR002 INSTRUCTION MANUAL

IMPORTANT SAFETY INSTRUCTIONS



CAUTION

This symbol indicates information on how to avoid damaging the unit.



WARNING

This symbol indicates information concerning your personal safety.



IMPORTANT

This symbol indicates tips and information about setting up FR002 (Charging Base).



CAUTION / WARNING

- Read all instructions before using the product.
- To reduce risk of injury, close supervision is necessary when the product is used near children.
- Use of an attachment not recommended or sold by power bank manufacture may result in a risk of fire, electric shock, or injury to persons.
- To reduce risk of damage to the electric plug and cord, pull the plug rather than the cord when disconnecting power pack.
- Do not operate the unit with a damaged cord or plug, or a damaged output cabled.
- Do not use if the unit has been damaged or modified. Damaged or modified batteries may exhibit unpredictable behaviour resulting in fire, explosion or rick of injury.
- Do not disassemble the power bank, take it to a qualified service person when a service or repair is required. Incorrect assembly may result in a risk of fire or electric shock.
- Do not exposed to water.
- This unit may become hot when recharging, handle with care.
- Do not leave in hot conditions 60C or above e.g., left sitting in hot car.
- Do not operate unit outside of specified conditions.
- This unit contains Li-ion 18650 or equivalent cells.
- Do not expose to heat or throw in fire.
- Do not attempt to modify.
- Be careful when unpackaging the unit. Do not use sharp objects when removing the packaging as this may cause scratches to the unit.

SAVE THESE INSTRUCTIONS

Contents

Specification.....	3
Product Overview	
FR001.....	3
FR002.....	4
Setting up FR002	4
Setting up & Recharging	4
Using the power bank	5
User Maintenance Instructions	5
Moving and Storage Instructions	5
Disposal of Product.....	5
Trouble Shooting.....	6

Specification FR001

Model: FR001

Battery cells: Li-ion 18650

Battery Capacity: 18900mAh*(+/- 5%)

Input (Power in contacts): DC 20V/1.25A (max)

Type-C output: DC 5V/3A, 9V/3A, 15V/3A, 20V/3A (PD3.0 60W)

Type-A output: DC 5V/3A, 9V/2A, 12V/1.5A (QC3.0 18W)

Total output: 78W (Both ports combined)

Dimensions: 136mm diameter x 33mm tall

Weight: 0.46KG

Operation Temperature: 5~35C

Packaging Content: 1 x FR001

Specification FR002

Model: FR002

Power Input: 20V/7.5A

Power output: 19.5V/7.5A

Dimensions: 145mm diameter x 21.5mm tall

Weight: 0.34KG

Packaging content: 1 x FR002, 1 x AC Power Cord, 1 x Power Supply (20V/7.5A)

Product Overview – FR001

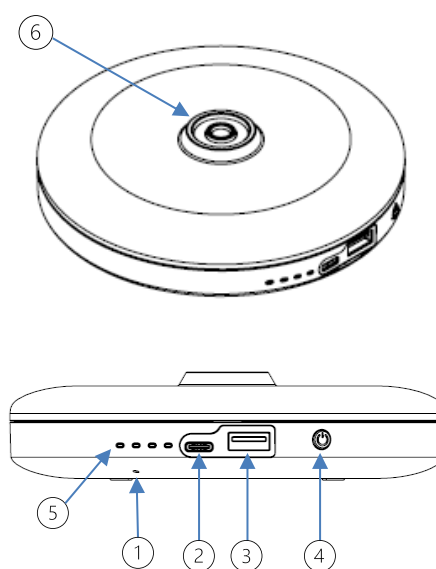

- ① Reset button location
- ② USB C Port
- ③ USB A Port
- ④ Power Button
- ⑤ LED Charge level indicator
- ⑥ Power Contact Rings

Product Overview – FR002

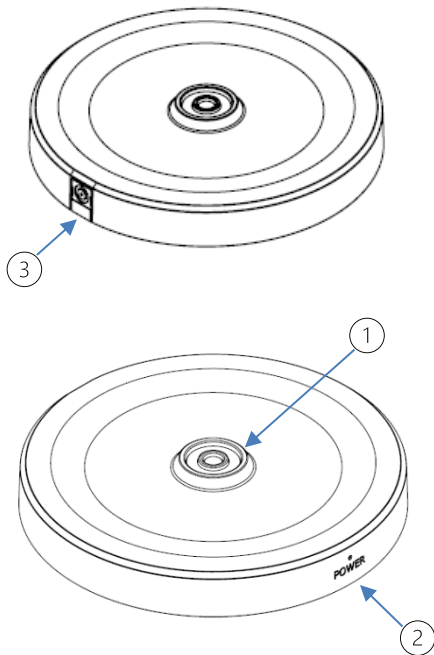

- ① Power Out Contact Rings
- ② Power Indicator
- ③ D.C. Jack – Power In

Setting Up FR002

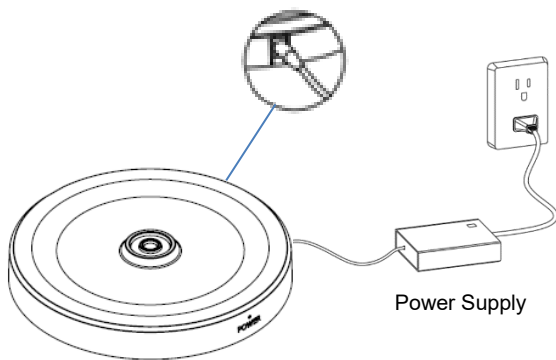

1. Plug the AC cord into the power supply.
2. Plug the AC plug into an outlet.
3. Plug the power out lead from the power supply into the DC jack on at the back of FR002. Power indicator will illuminate green.

Setting Up & Recharging FR001



Setting up

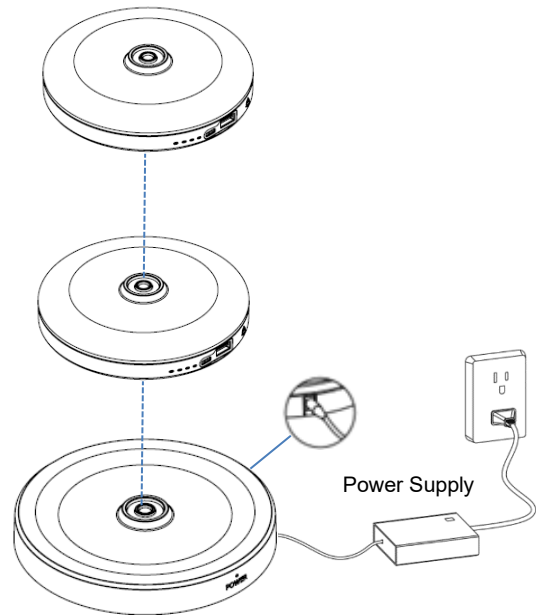

To recharge the power bank, place it onto the dedicated charging base (FR002). The power bank will be recharged via the contact pins on the base of each unit. Multiple power banks can be stacked on top of one another when recharging.

The dedicated charge base (FR002) can support 5 units with recharge times around 3.3 hours, or 5 plus units at extended recharge times. *

☀ ☀ ☀ ☀	100%
☀ ☀ ☀ ☀	76% - 99%
● ☀ ☀ ☀	51% - 75%
● ● ☀ ☀	26% - 50%
● ● ● ☀	1% - 25%

☀ ..FLASH ☀ ..ON ● ..OFF

A white LED will flash to indicate the power bank is recharging. As the unit charges the additional LED(s) will remain on until all four LEDs are on constantly.

Using the Power Bank

FR001 can recharge any USB C or USB A compatible device(s). Simply plug in the device and press the power button on freedom to turn it on. Four white LED's will illuminate.

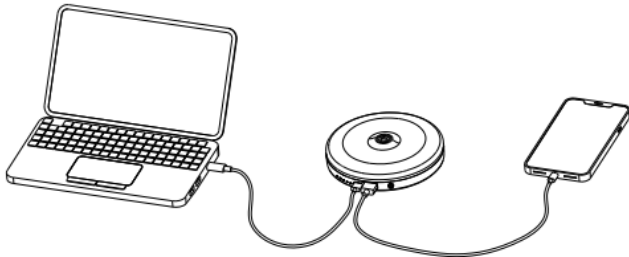

As FR001 discharges your device each LED will go out systematically until the unit is depleted.

☀ ☀ ☀ ☀	100% - 75%
● ☀ ☀ ☀	74% - 50%
● ● ☀ ☀	49% - 25%
● ● ● ☀	24% - 1%
● ● ● ☀	1 - 0%

☀ ..FLASH

☀ ..ON

● ..OFF

User Maintenance

Instructions



Important – Cleaning

When cleaning FR001 do not spray cleaner directly onto unit. Spray onto cloth and wipe down the unit. Only spray enough cleaner that the cloth is just damp to the touch.

When cleaning FR002 disconnect from mains power before wiping down. Do not spray cleaner directly onto unit. Spray onto cloth and wipe down the unit. Only spray enough cleaner that the cloth is just damp to the touch.

Moving & Storage

Instructions



Important - Long Term Storage

When storing FR001 for extended periods of time you MUST discharge and recharge the unit at least every 6 months to maintain the integrity of the batteries.

Disposal of Product

This product contains lithium-ion batteries. At the end of the product life cycle the freedom unit must be disposed off at an appropriate waste facility.

Do not dispose of Freedom Unit in general waste.



Troubleshooting

Issue	Cause	Solution
All four LEDs flashing simultaneous	The over-current protection is activated during discharging.	Remove the over-loading device
	The over-temperature protection is activated during charging.	The Unit stopped charging as the device operating temperature has been exceeded. The unit will resume function after returning to operating temperature range.
The power bank cannot be charged.	The firmware is shutdown.	press the reset button.
	Contact pins are not making good contact with the charging plates.	Check that no debris is impeding recharging via the contact rings/pins and try again
your plugged-in device(s) are not charging.	There is no capacity left.	Re-charge the power bank.
	The firmware is shutdown.	Press the reset button.
	The power bank isn't turned on.	Press the power button
	The connection cable is not good.	Make sure the cable is in good condition and undamaged. You may need to try with another cable.
Unit run time is low	The capacity left is low	Re-charge the power bank.
	The working current of devices is larger.	Battery degradation over time/usage
	Battery is close to end of life	Battery degradation over time/usage
Unit is Unresponsive	The Unit software is frozen/unresponsive	Press and hold RESET button for 10 seconds (Rest Button located on the underside of the unit).