

ASSEMBLY INSTRUCTION MANUAL

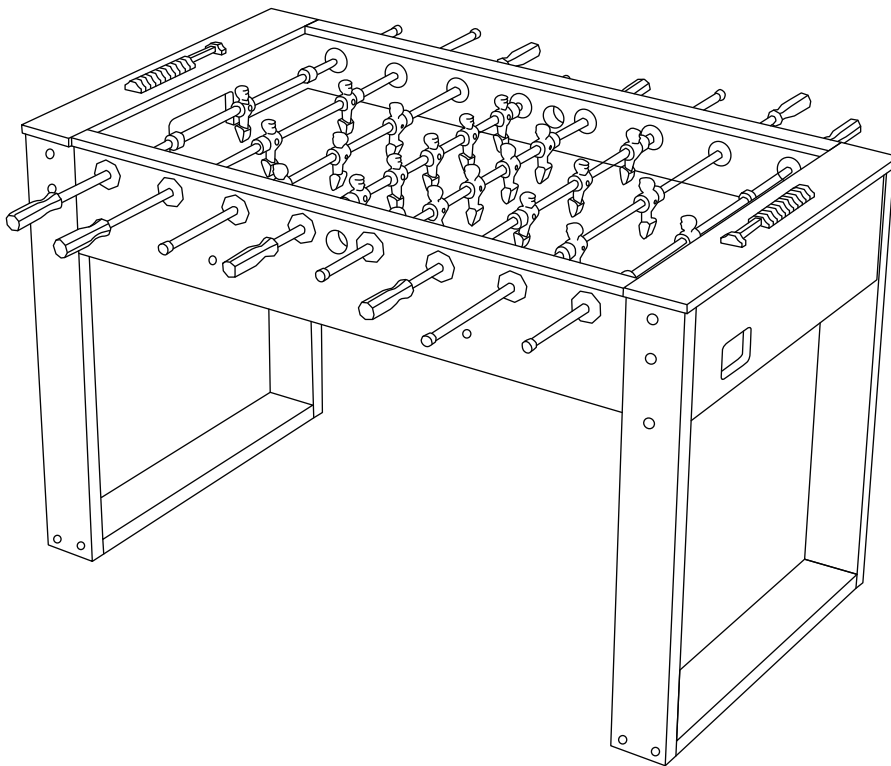

STRIKER FOOSBALL TABLE













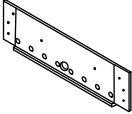
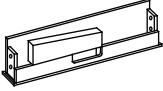
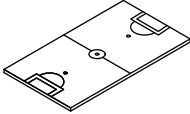
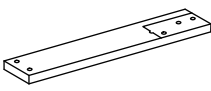

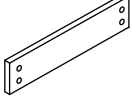



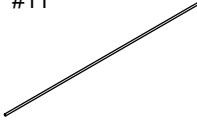
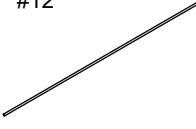









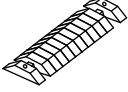



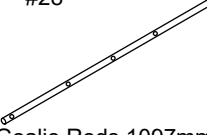
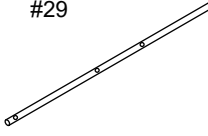
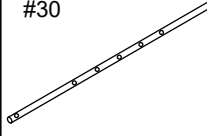
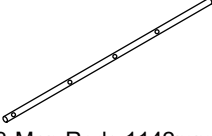

ITEM NO. 51906534000
REV. 1 DATE: Feb. 2021

Congratulations! we hope you will have many hours to use your new Foosball table and enjoy the pleasure it brings to you!

Please carefully read all safety instructions and directions before proceeding

- 1) Your table is designed for use indoor only. Damage can occur if the table is exposed to water, dampness, high humidity, freezing temperatures, etc.
- 2) The foosball table is heavy. Two or more people are required for assembly.
- 3) Only use the table for its intended purpose.
- 4) Damaged or worn parts may be dangerous for users and the integrity of the table. Replace worn or damaged components immediately and do not use the table until any issues have been resolved. For best results, use only spare parts supplied by Supplier.
- 5) Unauthorized repairs or altering the table's design or functions may be dangerous and will void the warranty.
- 6) Check all screws, bolts, etc. on a regular basis to ensure that they are in good working condition and have not loosened over time.
- 7) Please keep the balls, lubricant and other parts out of reach of children and pets.
- 8) This is not a toy. Adult supervision is recommended when being used by children.
- 9) Please use care when pushing or pulling the rods so people or objects nearby do not get injured or damaged.

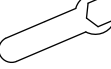
Part List

<p>#1</p>  <p>Side Apron 2PCS</p>	<p>#2</p>  <p>End Apron 2PCS</p>	<p>#3</p>  <p>Playfield 1PC</p>	<p>#4</p>  <p>Legs 4PCS</p>	<p>#5</p>  <p>Leg Panels-1 2PCS</p>	<p>#6</p>  <p>Leg Panels-2 2PCS</p>
<p>#7</p>  <p>Playfield Support Beam 2PCS</p>	<p>#8</p>  <p>F4x1"Screws 4PCS</p>	<p>#9</p>  <p>F3.5x35mmScrews 8PCS</p>	<p>#10</p>  <p>M8x22mm Bolts 12PCS</p>	<p>#11</p>  <p>Connecting Long Bolt 744mm 2PCS</p>	<p>#12</p>  <p>Connecting Long Bolt 752mm 4PCS</p>
<p>#13</p>  <p>5/16"x2-3/4" Bolts 4PCS</p>	<p>#14</p>  <p>5/16"x3/4" Washers 8PCS</p>	<p>#15</p>  <p>5/16" Lock Nuts 4PCS</p>	<p>#16</p>  <p>5/16"x1-1/2" Bolts 4PCS</p>	<p>#17</p>  <p>5/16" Spring Washers 4PCS</p>	<p>#18</p>  <p>1/4"x2-1/2" Bolts 8PCS</p>
<p>#19</p>  <p>1/4"x5/8" Washers 8PCS</p>	<p>#20</p>  <p>1/4" Horizontal Nuts 8PCS</p>	<p>#21</p>  <p>Bracket 4PCS</p>	<p>#22</p>  <p>T4x12mm Screws 16PCS</p>	<p>#23</p>  <p>Counters 2PCS</p>	<p>#24</p>  <p>8#x1-1/4" Bolts 22PCS</p>
<p>#25</p>  <p>8#x1 Bolts 4PCS</p>	<p>#26</p>  <p>Nuts 26PCS</p>	<p>#27</p>  <p>Players 22PCS</p>	<p>#28</p>  <p>Goalie Rods 1097mm 2PCS</p>	<p>#29</p>  <p>2-Man Rods 1271mm 2PCS</p>	<p>#30</p>  <p>5-Man Rods 1028mm 2PCS</p>
<p>#31</p>  <p>3-Man Rods 1142mm 2PCS</p>	<p>#32</p>  <p>Rod End Caps 8PCS</p>	<p>#33</p>  <p>Bushings 4PCS</p>	<p>#34</p>  <p>Bumpers 16PCS</p>	<p>#35</p>  <p>Plastic Washers 16PCS</p>	<p>#36</p>  <p>Triangle Blocks 4PCS</p>
<p>#37</p>  <p>Rod Handles 8PCS</p>	<p>#38</p>  <p>Soccer Balls 4PCS</p>	<p>#39</p>  <p>Lubricant 1PC</p>	<p>#40</p>  <p>5mm Allen Keys 2PCS</p>	<p>#41</p>  <p>Wrench 1PC</p>	<p>#42</p>  <p>13mm Wrench 1PC</p>
<p>#43</p>  <p>Leg Leveler 4PCS</p>					

STEP 1

Find a clean, level place to begin the assembly of your foosball table. We recommend building the table on the box top to protect the parts during assembly.

It is very important to assemble table on a level and flat surface. This will keep the end aprons and side aprons "FLUSH" on the top and bottom edges.

Attach **#1** Side Apron onto **#2** End Apron and **#4** Legs using **#13** Bolt, **#14** Washer and **#15** Lock Nuts as shown in **FIGURE 1**. Using **#40** Wrench to tighten the **#13** Bolt. Do not overtighten **#13** Bolt on this time.

Attach **#3** Playfield onto the **#1** Side Apron and **#2** End Apron as shown in **FIGURE 1**.

Attach the other **#1** Side Apron and **#2** End Apron and **#4** Legs using **#13** Bolt, **#14** Washer and **#15** Lock Nuts as shown in **FIGURE 1**. Using **#40** Wrench to tighten all **#13** Bolts on this time.

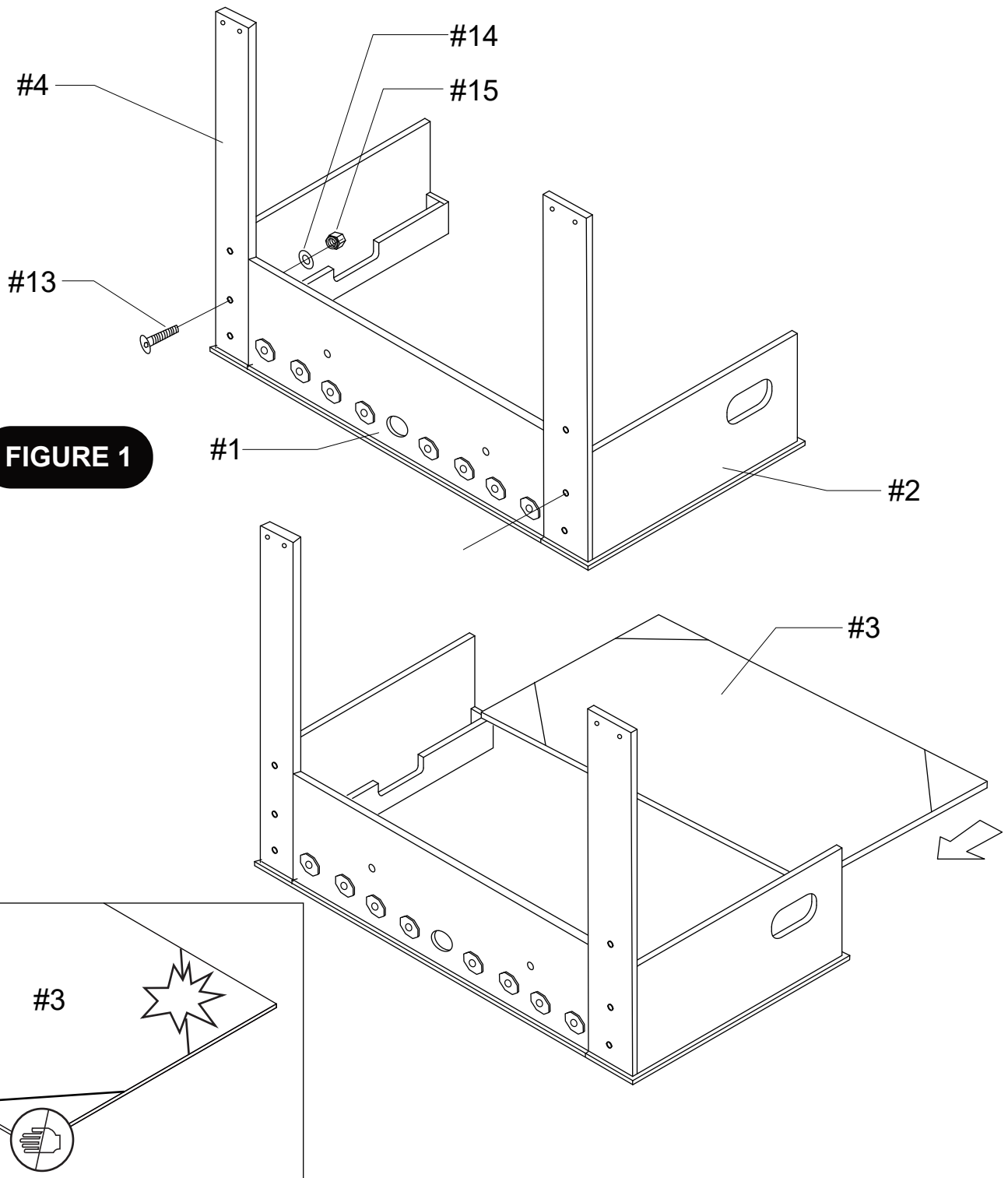

STEP 2

Attach the other **#1** Side Apron and **#2** End Apron and **#4** Legs using **#13** Bolt, **#14** Washer and **#15** Lock Nuts as shown in **FIGURE 1**. Using **#40** Wrench to tighten all **#13** Bolts on this time.

Attach **#3** Playfield onto **#2** End Apron using **#9** Screws as shown in **FIGURE 2**.

Attach **#3** Playfield onto **#1** Side Apron using **#36** Triangle Blocks as shown in **FIGURE 2**.

Attach **#1** Side Apron onto **#4** Legs using **#16** Bolt, **#17** Lock Washers and **#14** Washer as shown in **FIGURE 1**. Using **#40** Wrench to tighten the **#16** Bolt.

Attach **#11** Connecting Long Bolts onto the table cabinet using **#10** Bolts as shown in **FIGURE 2**.

Attach **#12** Connecting Long Bolts onto the table cabinet using **#10** Bolts as shown in **FIGURE 2**. Using **#40** Allen wrench to tighten the **#10** Bolts.

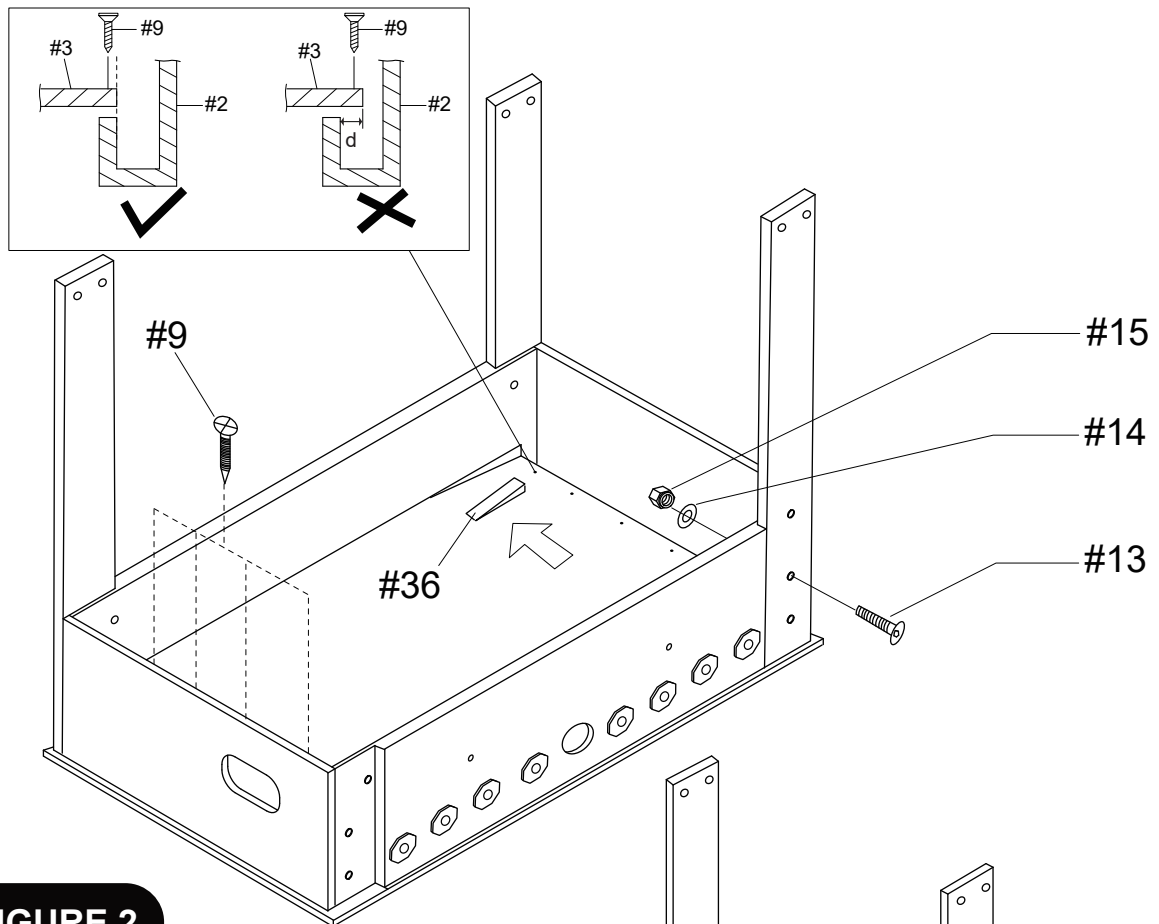
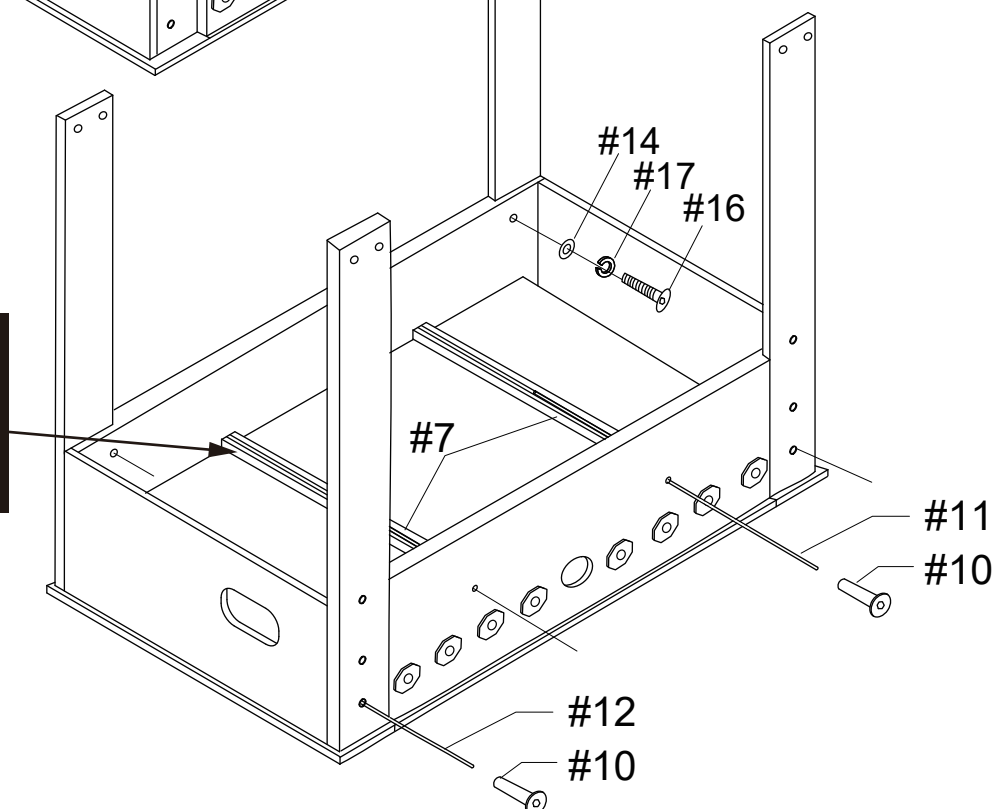

FIGURE 2

IMPORTANT NOTE:
Slide the middle two **#11** Connecting Long Bolts through the grooves of **#7** playfield Support Beams.



STEP 3

Attach the #5 Leg panels-1 onto the #4 Legs using #21 Bracket and #22 Screws as shown in **FIGURE 3**.

Attach #12 Connecting Long Bolts onto the table cabinet using #10 Bolts as shown in **FIGURE 3**. Using #40 Allen wrench to tighten the #10 Bolts.

Attach the #6 Leg panels-2 onto the #4 Legs using #18 Bolts, #19 Washers and #20 Horizontal Nuts as shown in **FIGURE 3**. Use #40 Allen Wrench to tighten all legs.

Screw #43 Leg Levelers into the bottom of each leg as shown in **FIGURE 3**.

Very carefully turn the table over and set it on its legs.

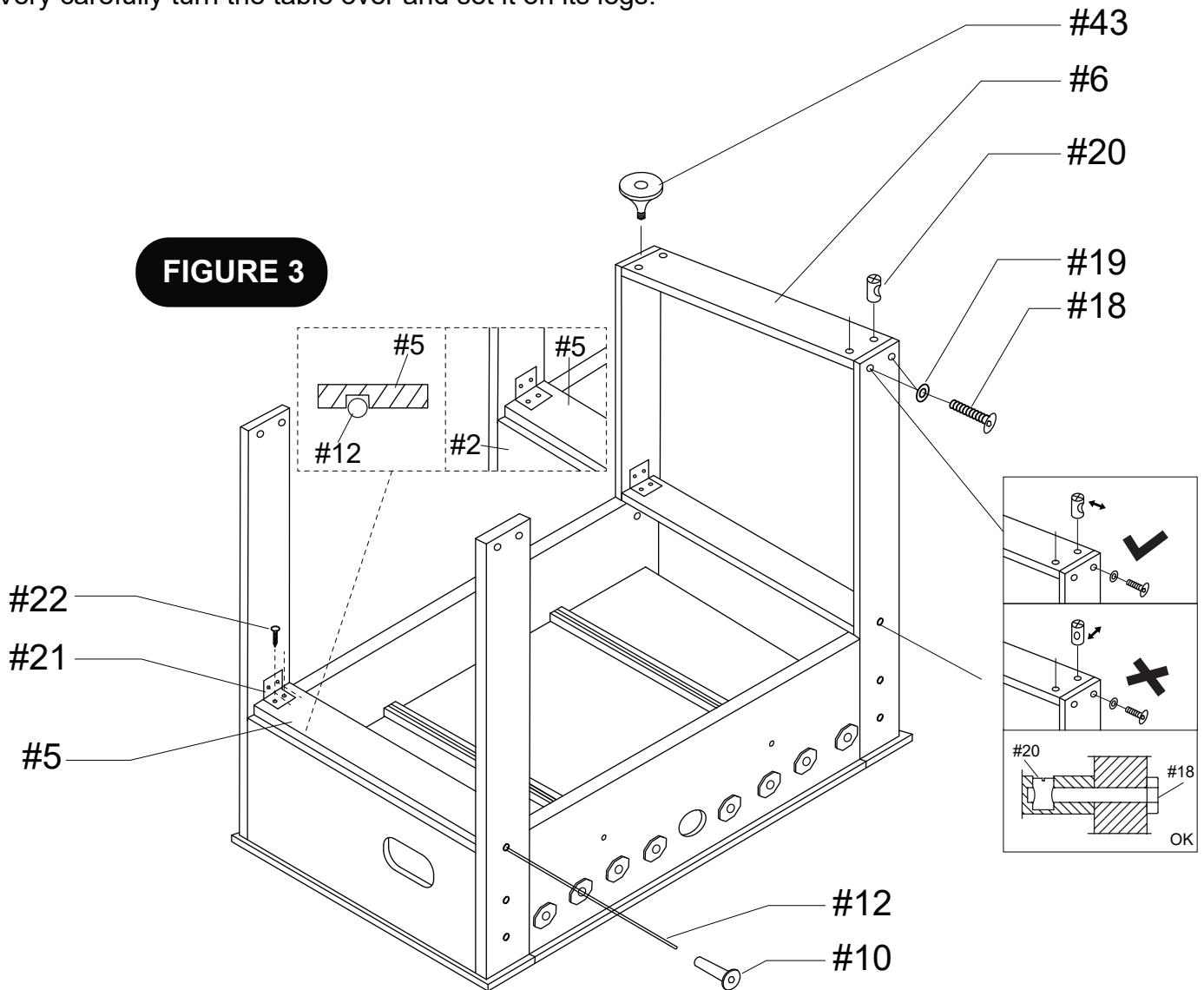

WARNING:
THIS STEP REQUIRES FOUR OR MORE ADULTS.
VERY CAREFULLY TURN THE TABLE OVER AND SET IT ON ITS LEGS. BE CAREFUL. THE TABLE IS VERY HEAVY.

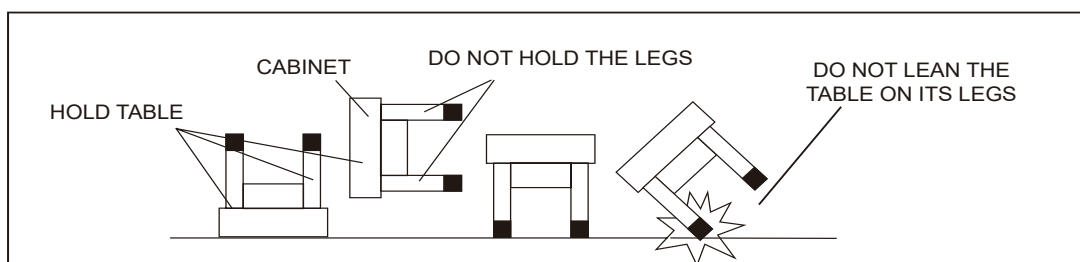

STEP 4

Slide the Player Rods (#28-31) through the table bushings at one side of the table in the order shown in **FIGURE 4**.

Place one #34 Bumper, and one #35 Plastic washer on either side of each Player Rod (#28-31) shown in **FIGURE 4**.

Now slide the Player Rods (#28-31) through the bushings at the other side of the table.

Attach the #27 Players onto the Player Rods(#28-31), using #24 Bolts and #26 Nuts as shown in **FIGURE 4**.

Attach the #33 Bushings onto the #28 Player Rods, using #25 Bolts and #26 Nuts as shown in **FIGURE 4**.

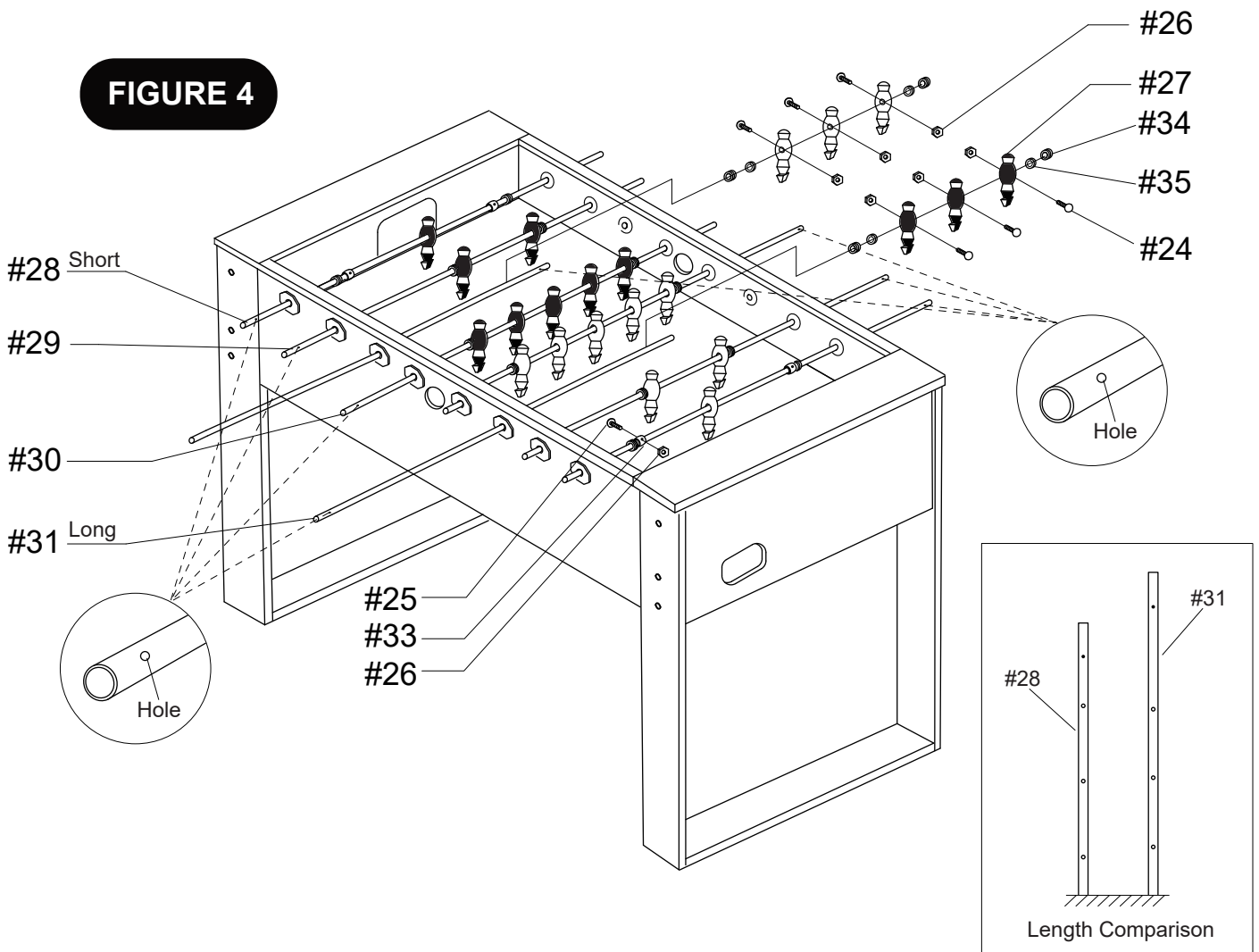

STEP 5

Attach the **#23** Counters onto **#2** END Aprons using **#8** Screws. Tighten but DO NOT Strip out screws.

Insert the **#37** Rod Handles onto the rods end.

Insert the **#32** Rod Ende Cape onto the rods end.

Spray the **#39** lubricant into a clean, soft cloth and then use the cloth to wipe the player rods where they come into contact with the bearings as shown in **DETAIL A**.

FIGURE 5

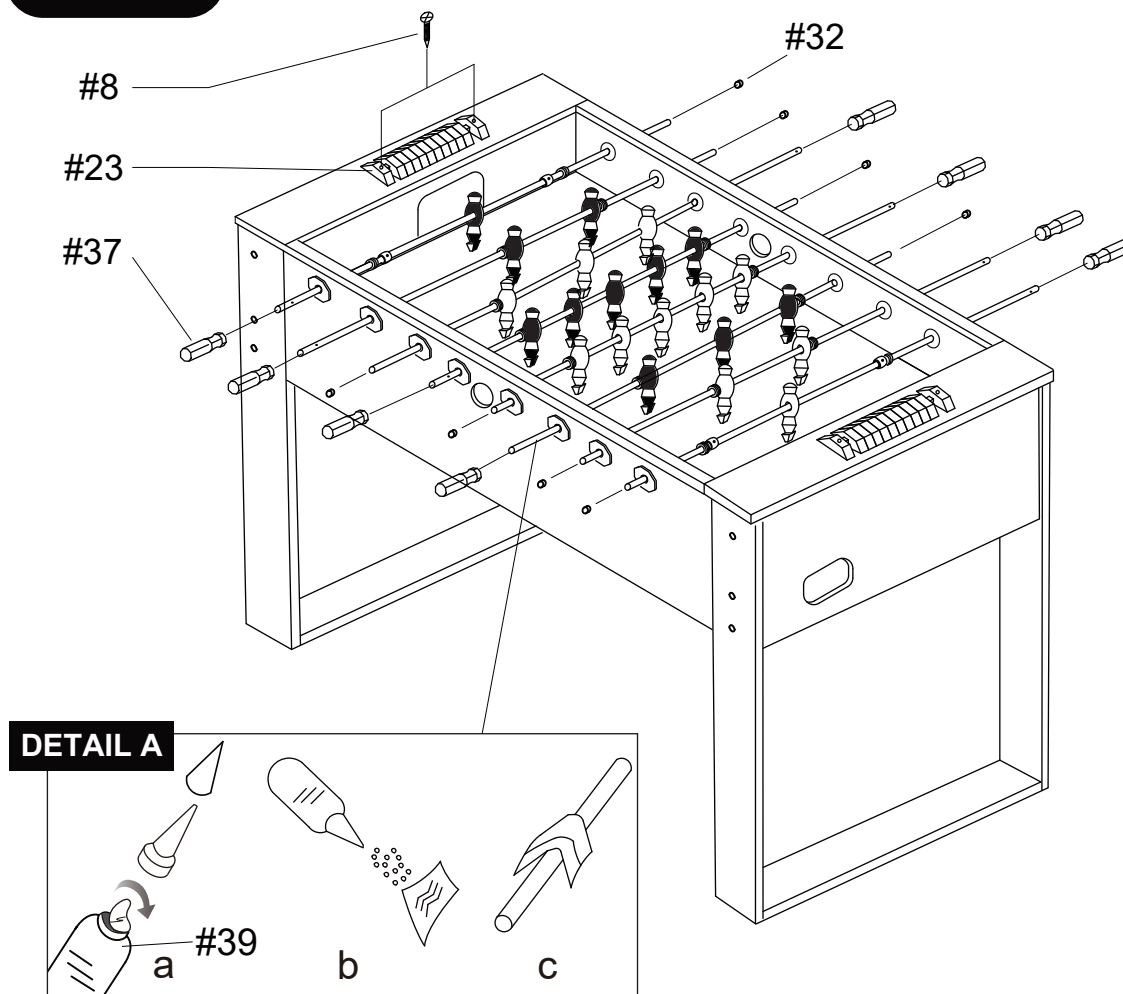

TABLE MAINTENANCE	
TABLE SURFACE	Keep your table covered. If there is dust on the playfield or the aprons, use a vacuum or wipe with a clean, soft cloth to remove. Do not sit on the table and do not use the table outside.
RODS	Occasionally wipe the rods with a clean, soft cloth. Never lift the table by the rods. Do not spin or press the rods too aggressively, as this may cause damage. We recommend the use of lubricant to wipe the Player Rods and Bearings from the outside of the game so as not to drip onto the playfield.
LEGS	Check that the leg bolts are tight. When moving the table, lift table off of its legs and place it down squarely on the legs, do not drag the table.
METHOD	Please make sure that all the screws, bolts are tightened before using. The table can't be hit by external force or used rough.

GAME RULES:

Flip A Coin - A coin flip decides who serves the foosball to start the foosball game. After the first goal is scored, the rule is that the team who was last scored on gets to serve the next ball. This rule keeps the game fair for both opponents. The foosball must be touched by a man before the ball goes into a goal for a legal goal to occur.

No Spinning - A spin is a rule for when the rod completes a 360 degree rotation without touching the ball. This is deemed an illegal move in the rules of foosball.

No Jarring - Jarring is a rule for when a player slams his or her rods against the wall of the foosball table in an attempt to distract or jar the foosball loose from the other player's possession. The rule is that there is no jarring allowed at any point during a game. This is not the same as when a player on the opposite team moves his or her foosball rods back and forth in an attempt to play defense. The key this rule is when a player hits the wall of the table with enough force to jar the ball or distract the opponent. That is why this is a subjective rule that may be called more strict by certain foosball players.

Dead Balls - If a foosball stops in the middle of two opposing team rods, the ball must be picked up and reserved. The serve goes back to the team that was last scored on. If a dead ball occurs on the defensive side of the table behind the defensive 2 bar, the defensive player must move the ball back into playing position. This rule is in place so players don't cause a dead ball on purpose in order to force a reserve.

Out of Play - If a ball comes off the table area or hits a top rail and comes back into the table area, the ball is ruled out of play and must be reserved by the team that was last scored on.

5 Bar Passing - These 5-bar passing rules are a little complex if you have never played tournament foosball. These passing rules do not apply to the other foosball rods, just the 5-bar. You are required to pass the ball within a 10 second from your 5-bar rod to the 3-bar rod directly after a serve. After the initial serve, you then are allowed 15 seconds to pass from the 5-bar. A ball cannot be completely stopped on the 5-bar and passed forward to the 3-bar, it must be moving and touch 2 men on the 5-bar before being advanced. Additionally, the ball can only touch the wall 2 times in a row (before touching a man again on the 5-bar) before being advanced. However, it can touch the ball the 3rd time if it is part of the pass.