

TB 120/TB 126J

TELESCOPIC BOOM LIFTS



- Reliable and robust diesel telescopic boom lifts
- Available with and without a jib boom
- Powerful 4 wheel drive
- Simple to operate and maintain
- Ideal for construction applications

 **snorkel**

AUSLIFT
EQUIPMENT 

TELESCOPIC BOOM LIFTS

TB120/TB126J

DIMENSIONS	TB120	TB126J
Max. working height	38.6m	40.4m
Max. platform height	36.6m	38.4m
Max. working outreach	18.9m	19.2m
Platform size	2.44m x 0.91m	2.44m x 0.91m
Overall width (A)	2.6m	2.6m
Operational width	3.9m	3.9m
Overall length (B)	12.9m	13.6m
Stowed height (C)	3.0m	3.2m
Ground clearance	330mm	330mm

PERFORMANCE	TB120	TB126J
Platform capacity (SWL)	227kg	272kg
Max. drive height	36.6m	38.4m
Max. wind speed	12.5m/s	12.5m/s
Max. drive speed (stowed)	4.6km/h	4.6km/h
Max. drive speed (elevated)	0.24km/h	0.24km/h
Jib length	n/a	2.0m
Jib arc	n/a	135° (+70°/-65°)
Platform rotation	157°	150°
Turret rotation (continuous)	360°	360°
Tailswing (axles retracted)	2.04m	2.04m
Tailswing (axles extended)	1.38m	1.38m
Raise/lower time	208/215 sec	208/215 sec
Gradeability	25%	25%
Inside turning radius	6.5m	6.5m
Outside turning radius	10.1m	10.1m
Tyres	445-65 D22.5 foam filled lug	
Controls	proportional joystick	
Drive system	4 wheel drive	

POWER	TB120	TB126J
Power source	Kubota V2403 59 hp diesel - Tier 4 Final	

WEIGHT	TB120	TB126J
Weight	17,917kg	19,119kg

WORKING ENVELOPE

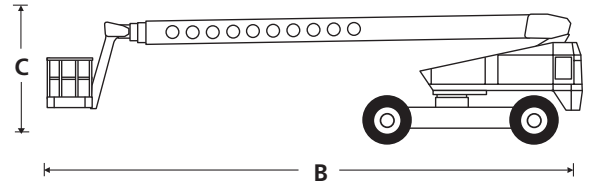
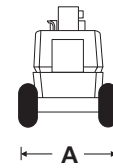
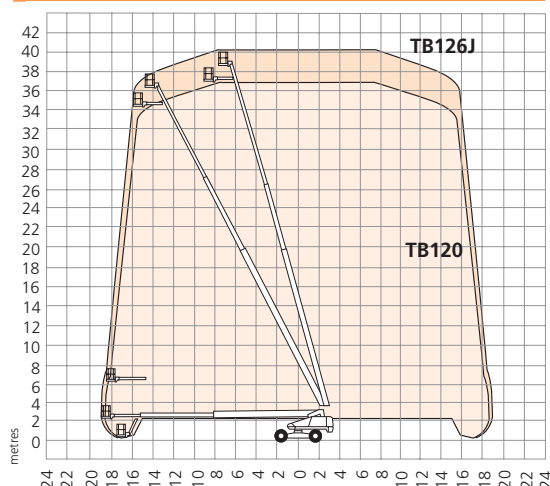

STANDARD FEATURES

- Snorkel Guard™ secondary guarding system
- 2.0m 135° jib (TB126J only)
- Four wheel drive, braking & fixed front steering
- Hydraulic platform rotation
- 360° continuous turntable rotation
- Hydraulic extended rear axles w/ boom interlocks
- Built-in jack for raising chassis
- Flashing amber light
- Proportional drive, boom lift, swing, extend & jib (if equipped)
- Foam filled lug tyres
- Power line to platform
- Dual lanyard attachment points
- 3.5° tilt alarm
- 2 year parts & labour, 5 year structural warranty
- CE approved

OPTIONS

- Special paint colours
- Airline to platform
- AC generator 110V/24V 2kW
- Cold weather package
- Extreme cold weather package
- Extreme environment package
- Light package
- Tow kit
- Glazier package
- 12k Generator package
- 12k Generator/Welder package
- Environmental hydraulic oil
- Tool tray

AUSLIFT EQUIPMENT

Auslift Equipment
2/2-4 Souffi Place, Dan
Dandenong South. Vic.3175
Email: sales@auslift.com.au
Telephone : 03 9702 7977
Website: www.auslift.com.au