

SJ12/16
VERTICAL MAST
LIFTS



STANDARD FEATURES

- 12.5 m/s wind rating (SJ12 only)
- Drivable at full height
- Variable speed, front two wheel hydraulic drive
- Zero inside turning radius
- Wet disc SAHR brakes
- Proportional controls
- 0.41 m traversing platform
- 24V DC power source
- Low voltage battery protection
- 30% Gradeability
- Solid rubber, non-marking tyres
- Pothole protection system
- Wiring for AC outlet at platform
- Tilt alarm with drive & lift cut-out
- All motion audible alarm
- Lanyard attachment points
- Operator horn
- Dual flashing lights
- Lift rings/tie downs
- Full height spring hinged gate
- Relay based control system
- Colour coded and numbered wiring system

ACCESSORIES AND OPTIONS

- AGM batteries
- Light duty pipe rack/steel stud rack
- Wind rating kit (SJ16 only)
- Tool tray
- Bio oil

† Standard lead times may be increased when optional equipment is added, consult factory.

‡ Capacities, and machine weights may differ when options are added.

SJ12/16 VERTICAL MAST LIFTS

AUSLIFT EQUIPMENT

Dimensions	SJ12	SJ16
A Work Height	5.65 m	6.75 m
B Raised Platform Height	3.65 m	4.75 m
C Lowered Platform Height	0.45 m	0.45 m
D Overall Width	0.77 m	0.77 m
E Overall Length	1.37 m	1.37 m
F Stowed Height	1.79 m	1.79 m
G Platform Width (Inside Dimension)	0.69 m	0.69 m
H Platform Length (Outside Dimension)	0.93 m	0.93 m

Specifications	SJ12	SJ16
Ground Clearance (Stowed)	5.33 cm	5.33 cm
Ground Clearance (Raised)	1.60 cm	1.60 cm
Weight	782 kg	966 kg
Local Floor Load (with rated load)	696 kPa	827 kPa
Local Floor Load (no load)	552 kPa	634 kPa
Gradeability	30%	30%
Turning Radius (Inside)	0	0
Turning Radius (Outside)	1.40 m	1.40 m
Drive Speed (Stowed)	4.0 km/h	4.0 km/h
Drive Speed (Raised)	0.80 km/h	0.80 km/h
Maximum Drive Height	Full Height	Full Height
Capacity (Overall)	227 kg	227 kg
Maximum # of Persons	2	2

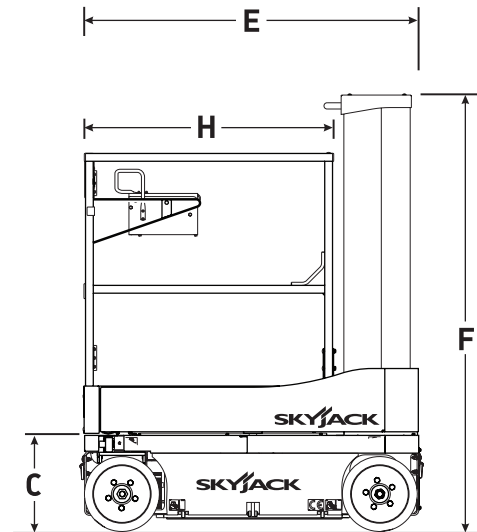
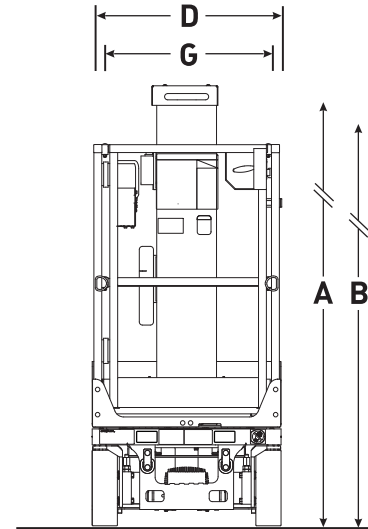

Distributed by: Auslift Equipment
 2/2-4 Souffi Place
 Dandenong South. Vic. 3175
 Telephone: 03 9702 7977
 Email: sales@auslift.com.au
 Website: www.auslift.com.au

This brochure is for illustrative purpose only and based on the latest information at the time of printing. Skyjack Inc. reserves the right to make changes at any time, without notice, to specifications, standard and optional equipment. Consult the Operating Maintenance and Parts Manuals for proper procedures. AS marked platforms are in conformance to Standard AS/NZS 1418.10:2011.