

Electric Series Scissor Lifts

1012SE (3346SE)

Complies with ISO/CE/ANSI/AS/CU-TR/KCS standards



Model		1012E (3346SE)
Dimensions		
Max Working Height		12m
A Max Platform Height		10m
B Max Horizontal Extension		0.9m
C Length-Stowed		2.45m
D Width-Stowed		1.17m
Height-Stowed	Rail Folded	1.86m
	E Fixed Rails	2.48m
F Wheelbase		1.88m
Ground Clearance (Pothole Guard Stowed)		0.1m
Ground Clearance (Pothole Guard Deployed)		25mm
Platform Dimensions (LxWxH)		2.30m x 1.5m x 1.1m
Performance		
Platform Allowable Occupants (Indoor/Outdoor)		2 Persons/1 Persons
Platform Capacity		320kg
Drive Speed-Stowed		4km/h
Drive Speed-Raised		0.8km/h
Elevation Time (Unloaded)		53s~58s
Decent Time (Unloaded)		40s~45s
Gradeability		25%
Turning Radius (Inside/Outside)		0/2.35m
Tilt Rating (Front to Back/Side to Side)		3°/1.5°
Tyres-solid		380x125mm
Power		
Batteries		6V x 4/240Ah
Power Source		24V DC
Drive Mode		Motor, front-wheel
Charger Input/Output		100~240V AC/30A
Hydraulic System Capacity		34L
Weight		
Weight (Indoor/Outdoor)		2,645kg/2,815kg

Standard Features

- Maintenance-free battery
- Proportional control
- Bumper rail
- 4 x 2 drive
- Non-marking tyres
- Integrated hand shield
- Automatic braking system
- Emergency lowering system
- Emergency stop (at platform & ground controls)
- Fault diagnosis system
- Tilt protection
- Automatic pothole guard
- Drive at full height
- Forklift pocket and lifting eyes
- Electrophoresic paint technology
- Foldable guardrail
- Overloading sensing system

Optional Features

- Overhead anti-collision device
- AC power to platform
- Headlight
- RCBO

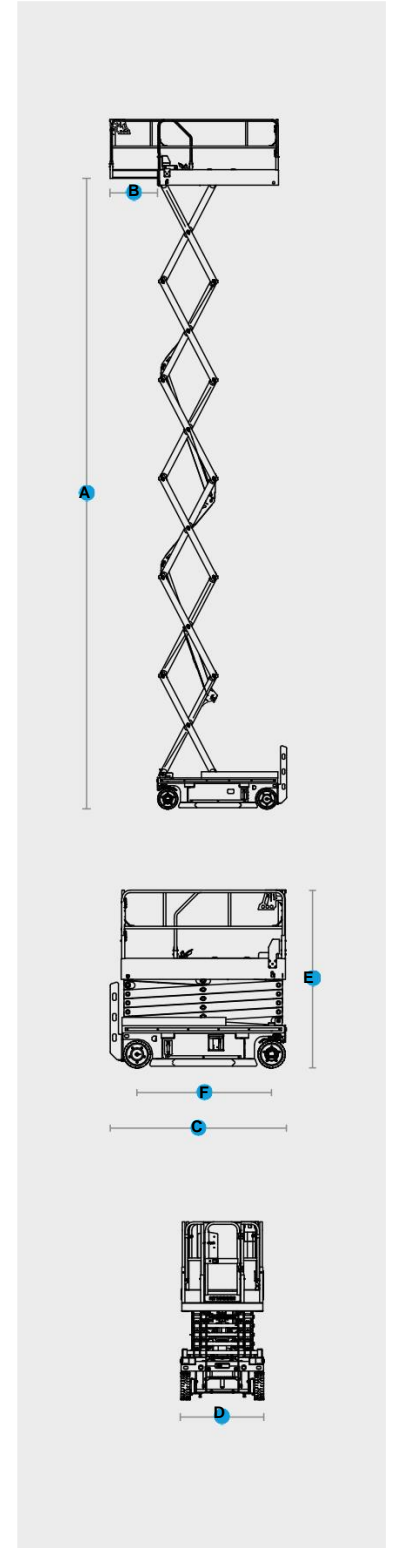

Auslift Equipment Pty. Ltd. (Australia)
 Factory 2/2-4 Souffi Place Dandenong South, Vic 3175
 T: (03) 9702 7977 E: sales@auslift.com.au
 www.auslift.com.au

