

Electric Series Scissor Lifts

0608SE (1930SE)

Complies with ISO/CE/ANSI/AS/CU-TR/KCS standards



Model		0608SE (1930SE)
Dimensions		
Max Working Height		7.8m
A Max Platform Height		5.8m
B Max Horizontal Extension		0.9m
C Length-Stowed		1.8m
D Width-Stowed		0.81m
Height-Stowed	Rail Folded	1.88m
	E Rail-Unfolded	2.14m
F Wheelbase		1.34m
Ground Clearance (Pothole Guard Stowed)		75mm
Ground Clearance (Pothole Guard Deployed)		24mm
Platform Dimensions (LxWxH)		1.64m x 0.76m x 1.1m
Performance		
Platform Allowable Occupants (Indoor/Outdoor)		2 Persons/-
Platform Capacity		230kg
Drive Speed-Stowed		4km/h
Drive Speed-Raised		0.8km/h
Elevation Time (Unloaded)		15s~20s
Decent Time (Unloaded)		25s~30s
Gradeability		25%
Turning Radius (Inside/Outside)		0/1.49m
Tilt Rating (Front to Back/Side to Side)		3°/1.5°
Tyres-solid		323x100mm
Power		
Batteries		6V x 4/225Ah
Power Source		24V DC
Drive Mode		Motor, front-wheel
Charger Input/Output		100~240V AC/30A
Hydraulic System Capacity		7L
Weight		
Weight (Indoor/Outdoor)		1,575kg

Standard Features

- Maintenance-free battery
- Proportional control
- Bumper rail
- 4 x 2 drive
- Non-marking tyres
- Integrated hand shield
- Automatic braking system
- Emergency lowering system
- Emergency stop (at platform & ground controls)
- Fault diagnosis system
- Tilt protection
- Automatic pothole guard
- Drive at full height
- Forklift pocket and lifting eyes
- Electrophoresic paint technology
- Foldable guardrail
- Overloading sensing system

Optional Features

- Overhead anti-collision device
- AC power to platform
- Headlight
- RCBO

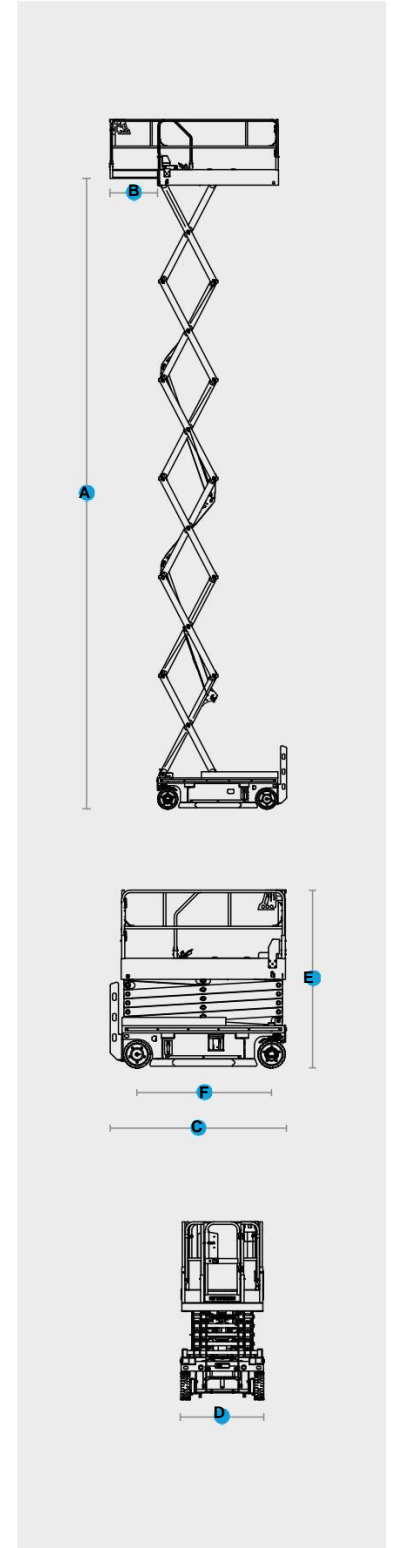

Auslift Equipment Pty. Ltd. (Australia)
 Factory 2/2-4 Souffi Place Dandenong South, Vic 3175
 T: (03) 9702 7977 E: sales@auslift.com.au
 www.auslift.com.au

