

ES2646

ELECTRIC SCISSOR LIFT

AUSLIFT
EQUIPMENT

SCISSOR LIFT

JLG

Performance

Platform Height	7.92 m
Working Height	9.92 m
Platform Capacity	545 kg
Capacity on Platform Extension	120 kg
Occupants (Indoor/ Outdoor)	2 / 1
Lift/Lower Time	49 /44 Seconds
Maximum Drive Height	Full Height
Weight*	2450 kg
Ground Bearing Pressure	9.6 kg/cm ²
Drive Speed–Elevated	0.8 km/h
Drive Speed–Lowered	4.8 km/h
Gradeability	25%
Turning Radius (Inside)	Zero
Turning Radius (Outside)	2.2 m

* Certain options or country standards will increase weight.

Standard Specifications

Power Source

Batteries	4 x 6V 220amp-hr
Charger	27 amp
Drive	24V Electric Front Wheel

Hydraulic Reservoir

• Capacity	6.4 L
• Pump	Fixed Displacement Gear

Tyres

• Tyre Size/Type (Non-Marking)	406 x 125 mm
--------------------------------	--------------

Brakes

- Electric / Multi-Disc Friction

Standard Features

- Proportional Controls
- Load Sensing System
- DC Electric Drive
- Smart Battery Charger CAN Enabled
- Battery Condition Indicator
- All Motion Alarm
- Horn
- Hourmeter
- Tilt Alarm and Light
- Lanyard Attach Points
- Moveable, Removable Platform Control
- Nickel Plated Pins
- Lubrication Free Scissor Arm Bushings
- Scissor Maintenance Prop
- Active Pothole Protection System
- Lifting and Tie Down Points
- Fork Lift Pockets
- Foot-Actuated Deck Extension
- Steel Swing-Out Doors
- Variable Tilt Visual Zone Indicator
- Manual Descent Cable
- Diamond Tread Steel Deck
- Greaseless Kingpin Joints
- Analyzer Port for Diagnostics
- Dynamic Braking
- Flashing Amber Beacon
- Self Closing, Self Latching Gate
- Fold Down Rails
- USB Charger and phone Holster
- MDI (Ground)
- Drive Motor Covers
- AS/NZS 1418.10 Compliance



Accessories & Options

- Fire Extinguisher
- Anti-Vandalism Package for Ground Controls and Platform Controls
- Ambient Noise (Squawker) Alarm
- AC Outlet To Platform incl. ELCB
- ClearSky
- SkySense
- Access Control
- Mobile Control
- Pipe Racks
- CleanGuard
- Tool Tray
- Reflective Tape

ES2646

ELECTRIC SCISSOR LIFT

AUSLIFT

EQUIPMENT

SCISSOR LIFT



Dimensions

All dimensions are approximate.

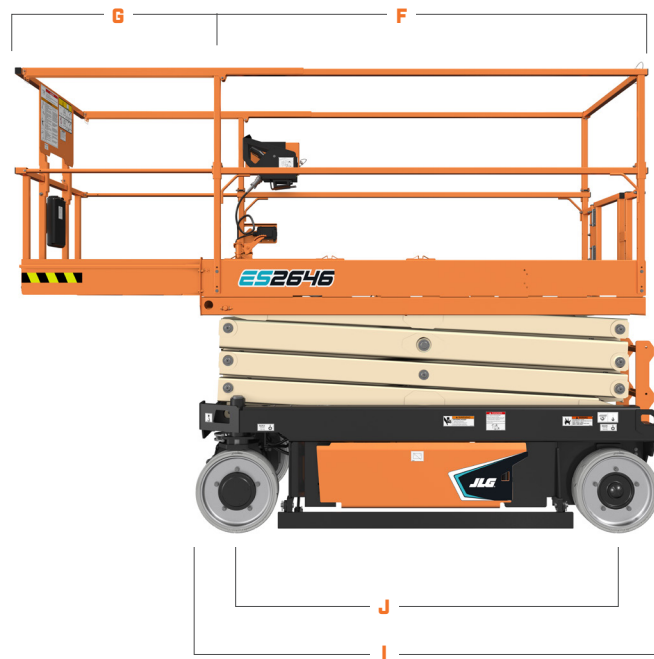
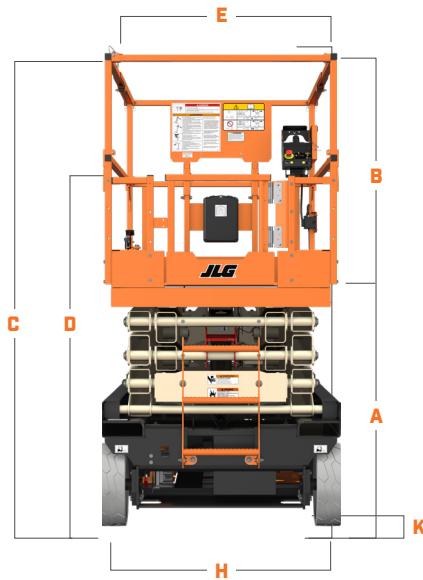

A. Platform Height-Lowered	1.14 m
B. Platform Railing Height	1.14 m
C. Overall Height	2.28 m
D. Overall Height (Rails Lowered)	1.82 m
E. Platform Width	1.10 m
F. Platform Length	2.10 m
G. Platform Extension	0.91 m
H. Overall Width	1.17 m
I. Overall Length	2.40 m
J. Wheelbase	1.90 m
K. Ground Clearance	0.10 m



The JLG "2 & 5" Warranty

JLG Industries, Inc. backs its products with its exclusive "2 & 5" Warranty. We provide coverage on all products for two (2) full years and cover all specified major structural components for five (5) years. Due to continuous product improvements, we reserve the right to make specification and/ or equipment changes without prior notification. This machine meets or exceeds AS/NZS 1418.10 2011 as originally manufactured for intended applications. Please reference the serial number plate on the machine for additional information.

Auslift Equipment Pty Ltd
2/2-4 Souffi Place
Dandenong South, Vic . 3175
Telephone 1300 287 543

www.auslift.com.au

R012522