

# ML12C/ML18C/ML24C

## MATERIAL LIFTS

**AUSLIFT**  
EQUIPMENT

9702 7977  
www.auslift.com.au



- A high specification material lift, with best-in-class load capacity
- Can pass through a standard doorway
- Robust and reliable
- Features a dual handle, shift-on-the-fly, two-speed winch for improved productivity

**snorkel**<sup>TM</sup>

www.auslift.com.au

# ML12C/ ML18C/ML24C

## MATERIAL LIFTS

DIMENSIONS	ML12C	ML18C	ML24C
Lift height – forks up	4.0m	5.6m	7.4m
Lift height – forks down	3.5m	5.1m	6.9m
Stowed width <b>(A)</b>	0.77m	0.77m	0.77m
Stabiliser width <b>(B)</b>	1.63m	1.63m	1.63m
Stowed length	0.85m	0.85m	0.85m
Operating length <b>(C)</b>	1.75m	1.86m	2.06m
Stowed height <b>(D)</b>	2.2m	2.2m	2.2m
Fork width (outside)	0.58m	0.58m	0.58m
Fork length <b>(E)</b>	0.76m	0.76m	0.76m
Ground clearance	60mm	60mm	60mm

PERFORMANCE	ML12C	ML18C	ML24C
Max. load capacity (0.36m load centre)	340kg	318kg	295kg
Max. load capacity (0.61m load centre)	205kg	200kg	195kg
Max. load capacity (1.07m in load centre)	91kg	84kg	80kg
Min. load height	150mm	150mm	150mm
Winch (high speed)		13.1 cranks/m	
Winch (low speed)		49.2 cranks/m	

WEIGHT	ML12C	ML18C	ML24C
Weight	111kg	141kg	162kg

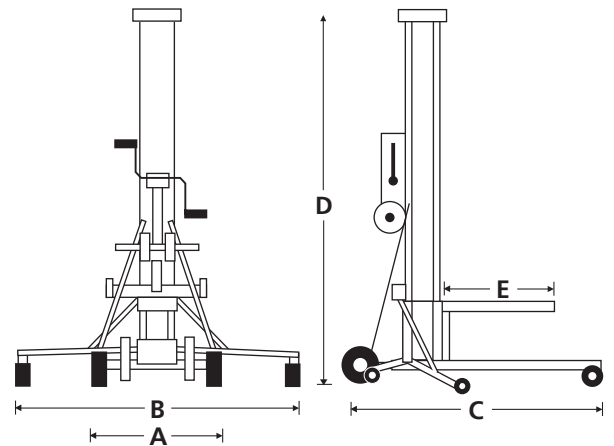

### STANDARD FEATURES

- Stabilisers with non-marking swivel casters (ML18C & ML24C)
- Mast brake
- Cable guard
- Non-marking transport/loading wheels
- Dual handle, two-speed shift-on-the-fly winch
- Metal cable pulleys with sealed bearings
- Heavy-gauge aluminium extrusions
- Heavy-duty, non-marking casters
- Quick-fold stabilisers
- Crane attachment point
- 2 year parts & labour, 5 year structural warranty
- CE approved

### OPTIONS

- Special paint colours
- Adjustable forks
- Boom
- Pipe cradle
- Fork extensions
- Load platform
- Stabilisers with non-marking swivel casters (ML12C)

### LOAD CAPACITY - STANDARD FORKS

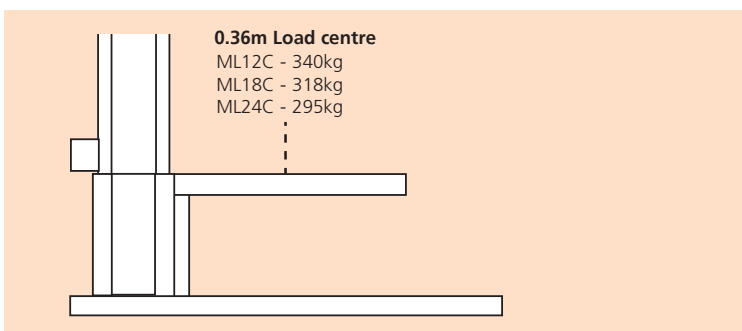

### LOAD CAPACITY - EXTENDED FORKS

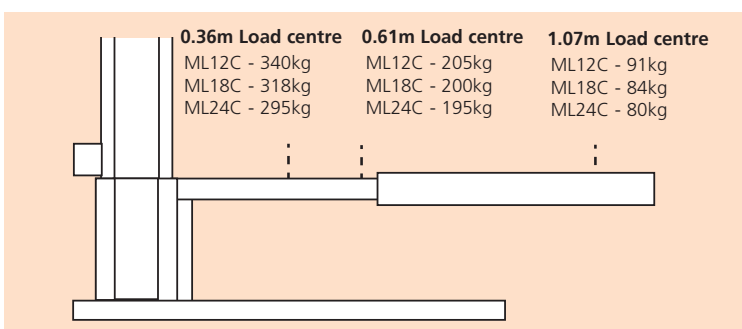

**snorkel**

2/2-4 Souffi Place  
 Dandenong South, Vic. 3175



t: (03)9702 7977  
 e: sales@auslift.com.au