

AUSLIFT
EQUIPMENT

liftsmart

LS15

Straddle Leg
Electric Stacker



1300 287 543

www.auslift.com.au

liftsmart[®] LS15

The Liftsmart LS15 series offers a strong, robust mast with an extension height of up to 3.3m. The external charger has also been designed to operate with greater reliability.

Thanks to Liftsmart's sleep model and low battery voltage alarm function, energy consumption is significantly reduced.

- ✓ Mid-driving unit with 3 point standing chassis design, reducing the risk of the drive wheel slipping or losing traction
- ✓ Ergonomically designed and built handle for comfortable operation
- ✓ Secure dustproof design improves the life of the machine
- ✓ Intelligent and modular control system ensures stable operation when lifting, lowering, moving and braking
- ✓ Upper mounted handle designed for easier operation and steering
- ✓ Wide mast provides high visibility, making lifting more precise and increasing safety
- ✓ With the flick of a switch, automatically limit maximum travel speed when the load is higher than 0.7m

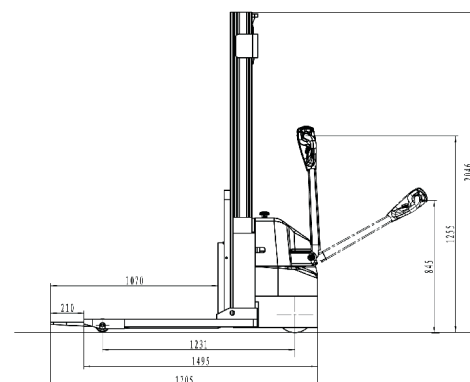
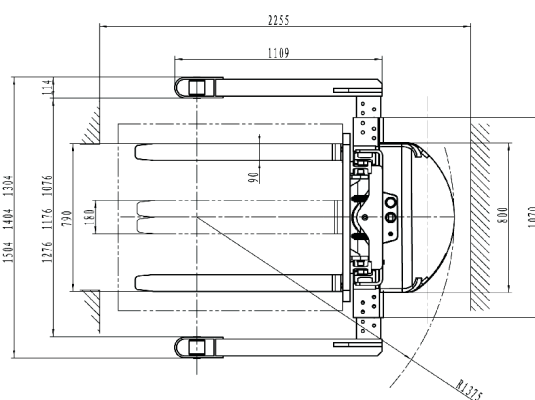

SPECIFICATIONS

Characteristics		Model		LS15
	1.1	Operator Type		Walkie
	1.2	Load Capacity	kg	1500
	1.3	Load Center	mm	600
	1.4	Wheelbase	mm	1231
Weight	2.1	Service Weight(Incl.Battery)	kg	510/580/610/640
Wheels	3.1	Tyre Type		PU
	3.2	Tyre Size, Drive Wheels	mm	Φ230x70
	3.3	Tyre Size, Load Wheels	mm	Φ84x70
	3.4	Tyre Size, Balance Wheels	mm	Φ115x55
	3.5	Wheels, Numbers(x=drive wheel)		1x+2
Dimensions	4.2	Height, Mast lowered	mm	2160/1795/2045/2195
	4.4	Lift Height	mm	1600/2500/3000/3300/3500/3600/4000
	4.5	Height, Mast Extended	mm	2150/3005/3505/3805/4005/4105/4505
	4.9	Height of tiller arm, Min/Max	mm	910/1230
	4.2	Fork Height, Lowered	mm	85
	4.2	Overall Length	mm	1705
	4.2	Overall Width	mm	
	4.2	Fork Dimension	mm	1070x100x30
	4.3	Outside Fork Width	mm	200-800
	4.3	Ground Clearance	mm	30
	4.3	AST, 1000X1200 pallet crosswaysmm		2255
	4.3	AST, 800X1200 pallet crosswaysmm		2180
	4.4	Outer Turning Radius	mm	1375
		Straddle leg OD	mm	1280/1480
		Straddle leg ID	mm	1180/1380
Performance	5.1	Travel Speed, Laden/Unladenkm/h		5.0/5.5
	5.2	Lifting Speed, Laden/Unladenm/s		0.20/0.21
	5.3	Lower Speed, Laden/Unladenm/s		0.12/0.11
	5.8	Max Gradeability, Laden/Unladen%		3.0/10.0
Drive	6.1	Drive Motor Rating S2 60Min	kw	1.10DC/AC
	6.2	Lifting Motor Rating S3 15%	kw	2.20DC
	6.4	Battery Voltage/Capacity(5h)	V/Ah	24/80
Others	7.1	Controller		PG
	7.2	Service Brake		Regenerate
	7.3	Parking Brake		Electromagnetic

Load Chart: LS15

Lift Height (mm)	Actual Capacity (kg)
0	1500
3000	1500
3500	1000
4000	600