

# ES SERIES - LIGHTWEIGHT

ES1330L/ES1530L ELECTRIC SCISSOR LIFTS - INDOOR AND OUTDOOR RATED

**AUSLIFT**  
EQUIPMENT

**JLG**  
reachingout®

## Performance

Platform Height-Elevated (Indoor/Outdoor)		
ES1330L	13 ft / 13 ft	3.8 m / 3.8 m
ES1530L	15 ft / 10 ft	4.5 m / 3 m
Platform Capacity (Indoor/Outdoor)		
ES1330L	500 lb / 500 lb	227 kg / 227 kg
ES1530L	500 lb / 500 lb	227 kg / 227 kg
Capacity on Platform Extension	250 lb	115 kg
Number of Occupants (Indoor/Outdoor)		
ES1330L	2 / 1	
ES1530L	1 / 1	
Lift/Lower Time	25/15 seconds	
Maximum Drive Height	Fully Elevated	
Weight*		
ES1330L	1,984 lb	900 kg
ES1530L	1,940 lb	880 kg
Ground Bearing Pressure		
ES1330L	119 psi	8.3 kg/cm <sup>2</sup>
ES1530L	116 psi	81 kg/cm <sup>2</sup>
Drive Speed-Elevated	0.5 mph	0.8 km/h
Drive Speed-Lowered	2.4 mph	3.8 km/h
Gradeability	25%	
Tilt Rating		
Fore and Aft	3.0 degrees	
Side to Side		
ES1330L - Indoor/Outdoor	1.75 degrees / 1.5 degrees	
ES1530L - Indoor/Outdoor	2.5 degrees / 1.5 degrees	
Turning Radius (Inside)	Zero	
Turning Radius (Outside)	55 in	1.4 m

\* Certain options or country standards will increase weight.

## Standard Specifications

### Power Source

Batteries	2 x 12V 105 amp-hr
Charger	27 Amp
Drive	24V Electric DC

### Hydraulic Reservoir

• Capacity	1.3 gal	5 L
• Pump	Fixed Displacement Gear	

### Tires

• Tire Size/Type (Non-Marking)	10 x 3 in	255 x 75 mm
--------------------------------	-----------	-------------

### Brakes

- Electric/Friction

## Standard Features

- Proportional Controls
- Battery Condition Indicator
- All Motion Alarm
- DeltaQ - 27 amp Multi-Function Universal Charger
- Horn
- Hourmeter
- Tilt Alarm and Light
- AC Receptacle in Platform
- Active Pothole Protection System
- Lifting and Tie Down Points
- Fork Lift Pockets
- Lanyard Attach Points
- Steel Swing-Out Doors
- Visual Variable Tilt Indicator
- Manual Descent Cable
- Diamond Tread Steel Deck
- Greaseless Kingpin Joints
- Analyzer Port for Diagnostics
- Dynamic Braking
- Movable, Removable Platform Control
- Nickel Plated Pins
- Lubrication Free Scissor Arm Bushings
- Scissor Maintenance Prop
- 22 in. (55 cm) Foot-Actuated Deck Extension
- Removable Ladder
- Self Closing Gate
- Load Sensing System

## Accessories & Options

- Anti-Vandalism Package
- Coiled Platform Control Box Cable
- Flashing Amber Beacon - LED
- Dual Flashing Amber Beacons - LED
- JLG™ Mobile Control
- MDI (Ground)
- CleanGuard™



**NOW  
OUTDOOR  
RATED**

# ES SERIES - LIGHTWEIGHT

ES1330L/ES1530L ELECTRIC SCISSOR LIFTS - INDOOR AND OUTDOOR RATED

**AUSLIFT**  
EQUIPMENT

**JLG**  
reachingout®

## Dimensions

All dimensions are approximate.

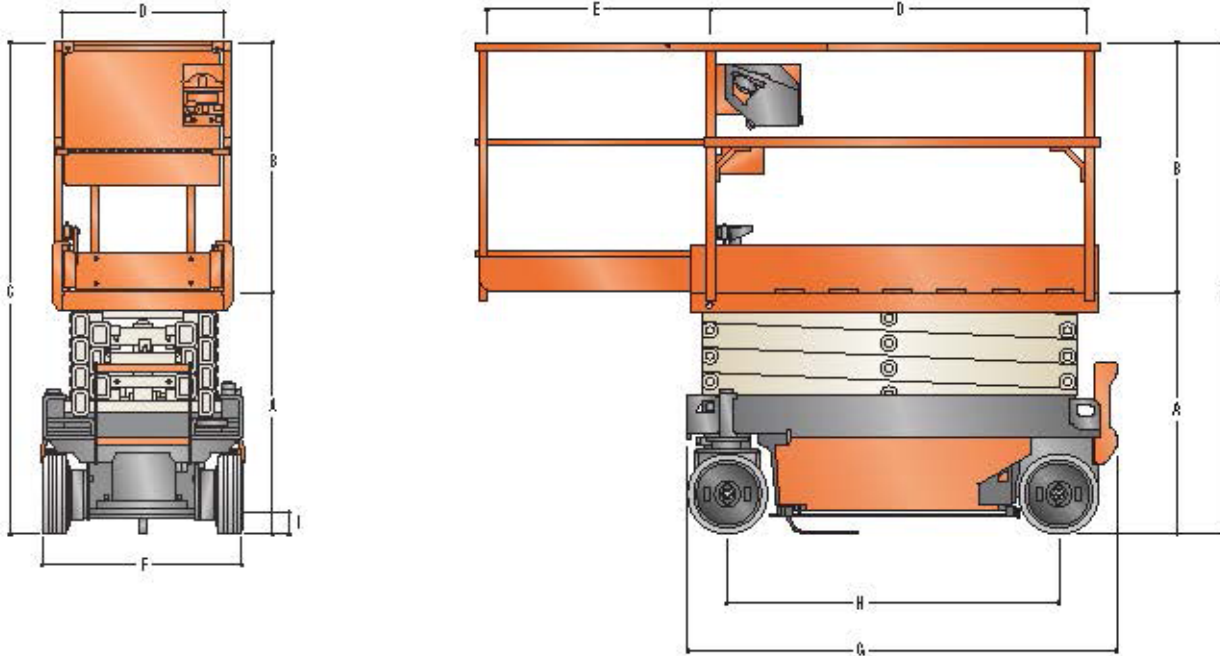

A. Platform Height-Lowered			
ES1330L	28.0 in.	0.7 m	
ES1530L	31.1 in.	0.8 m	
B. Platform Railing Height	43.3 in.	1.1 m	
C. Overall Height			
ES1330L	71.7 in.	1.8 m	
ES1530L	74.8 in.	1.9 m	
D. Platform Size	24.4 x 49.2 in.	0.6 x 1.3 m	

E. Platform Extension	216 in.	55 cm
F. Overall Width	30.0 in.	76 cm
G. Overall Length	56.2 in.	14 m
H. Wheelbase	42.3 in.	11 m
I. Ground Clearance	2.4 in.	6 cm

## The JLG "1 & 5" Warranty

We provide coverage for one (1) full year, and cover all specified major structural components for five (5) years. Due to continuous product improvements, we reserve the right to make specification and/or equipment changes without prior notification. This machine meets or exceeds applicable ANSI and CSA requirements based on machine configuration as originally manufactured for intended applications. Please reference the serial number plate on the machine for additional information.

**AUSLIFT**  
EQUIPMENT

9702 7977  
www.auslift.com.au

**JLG**

Auslift Equipment  
2/2-4 Souffi Place  
Dandenong South, Vic. 3175  
Telephone 03 9702 7977  
www.auslift.com.au