

1930 ES

ELECTRIC SCISSOR LIFT

AUSLIFT
EQUIPMENT

JLG

Performance

Platform Height—Elevated	5.72 m
Platform Capacity	230 kg
Capacity on Platform	120 kg
Extension Lift/Lower Time	26/30 seconds
Maximum Drive Height	Fully Elevated
Weight	1,575 kg
Drive Speed—Elevated	0.8 km/h
Drive Speed—Lowered	4.82 km/h
Gradeability	25%
Turning Radius (Inside)	Zero
Turning Radius (Outside)	1.75 m

Standard Specifications

Power Source

Batteries	4x6V 220 amp-hr
Charger	20 Amp Automatic
Drive	24V Electric 8hp

Hydraulic Reservoir

• Capacity	4.73 L
• Pump	Fixed Displacement Gear

Tyres

• Tyre Size/Type	12.5 x 4 in. Non-Marking Solid
------------------	--------------------------------

Brakes

• Electric/Friction

Dimensions

All dimensions are approximate.

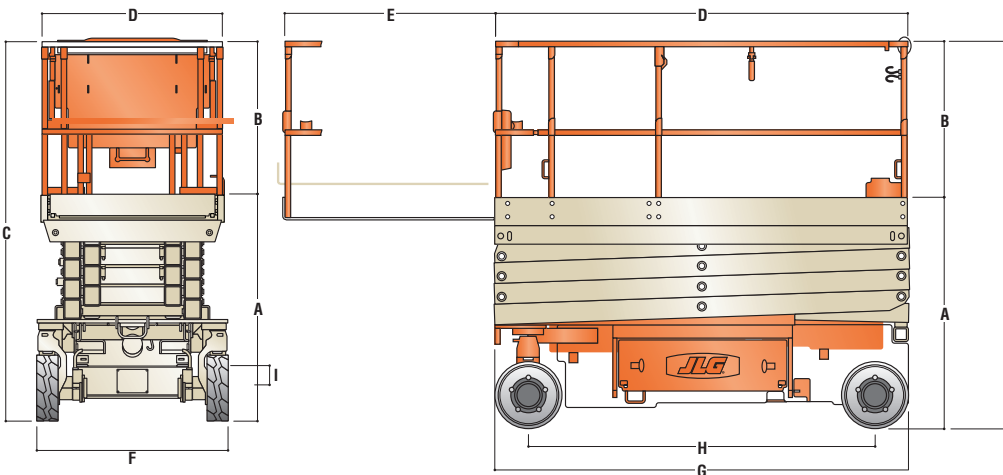

A. Platform Height—Lowered	0.86 m
B. Platform Railing Height	1.14 m
C. Overall Height	
Fixed rails	1.99 m
Fold Down Rails, Up	2.02 m
Rails Folded	1.52 m
D. Platform Size	0.76 x 1.87 m
E. Platform Extension	0.9 m
F. Overall Width	76 cm
G. Overall Length	1.87 m
H. Wheelbase	1.6 m
I. Ground Clearance	8.8 cm

Standard Features

- Proportional Controls
- Industry Leading Duty Cycles
- Self Closing and Locking Gate
- Battery Condition Indicator
- Slide-Out Battery Trays
- Automatic Traction Control (ATC)
- All Motion Alarm
- 20 Amp Automatic SCR Charger
- Horn
- Hourmeter
- Manual Descent Pull Cable
- Tilt Alarm and Light
- Moveable, Removable Platform Control
- Powder-Coated
- Console with Rail Mounting Bracket
- Nickel Plated Pins
- Lubrication Free Scissor Arm Bushings
- Scissor Maintenance Prop
- Mechanised Pothole Protection
- Machine Tie Downs
- Fork Lift Pockets, Lift from Side and Rear
- Flashing Amber Beacon
- Load Sensing System
- Lifting Lugs

Accessories & Options

- AC Outlet in Platform
- White Noise (squawker) Motion Alarm
- AGM Batteries
- Airline to Platform
- Special Hydraulic Oils
- Accessory Packages
 - Electrician's Package
 - Plumber's Package
 - JLG® Workstation
 - Pipe Rack Accessory
 - Plant Maintenance Package



u 'K8' . . . ‡
K8@ @
)
u o V-o

AUSLIFT
EQUIPMENT

JLG

AusliftEquipmentPty.Ltd.(Australia)
Factory 2/2-4 Souffi Place,
Dandenong South, Vic 3175
T: 03 9702 7977
www.auslift.com.au