

450AJ

ARTICULATING BOOM LIFT

Performance

Platform Height	13.72 m
Working Height	15.72 m
Horizontal Outreach	7.62 m
Up and Over Height	7.3 m
Weight	6,450 kg
Swing	355° Non-Continuous
Platform Capacity	250 kg
Platform Size	0.76 x 1.83 m
Platform Rotator	180°
Jib	1.24 m
Range of Articulation	144° (+76°, -69°)
Drive Speed	5.95 km/h
Gradeability	45%
Turning Radius (Inside/Outside)	2.06 m / 4.78 m

Standard Specifications

Power

Diesel Engine	Deutz D2011L03 Tier 4i (Interim)
Fuel Tank Capacity	64L

Tyres

Standard	Foam Filled Non-Marking
----------	-------------------------

Hydraulic System

Tank Capacity	136.27L
Systems Capacity	143.8L
Auxiliary Power	12V DC

Dimensions

All dimensions are approximate

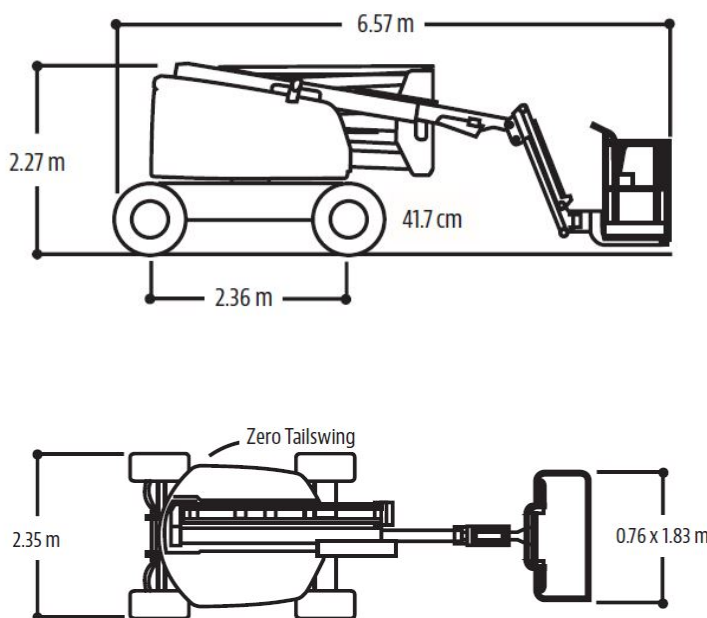

AUSLIFT
EQUIPMENT

JLG

Standard Features

- Generator Included Outlet to Platform and ELCB
- 1.24 m Articulating Jib
- 355° Non-Continuous Swing
- Platform 0.76 x 1.83 Side Entry Self-Closing, Self-Locking Gate
- 180° Hydraulic Platform Rotator
- Platform Console Machine Status Light Panel
- 5° Tilt Alarm / Indicator Light
- Flashing Amber Beacon
- Swing-Out Engine Tray
- Gull-Wing Steel Turntable Hoods
- 12V-DC Auxiliary Power
- Hourmeter
- Interactive Display at Ground Controls
- Proportional Controls
- Control ADE® System
- Lifting/Tie Down Lugs
- Horn
- Oscillating Axle
- Cast Aluminum Control Box
- Reduce Time to Full Height
- Motion Alarm

Accessories & Options

- 0.76 x 1.24m Platform
- Mesh to Mid Rail
- 1/2 in. Air Line to Platform
- Skyguard
- Platform Worklights
- Pipe Racks
- Special Hydraulics Oil
- Chassis Illumination Lights
- Squawkr / White Noise Motion Alarm
- Cable Ladder Carrier
- Hostile Environment Kit

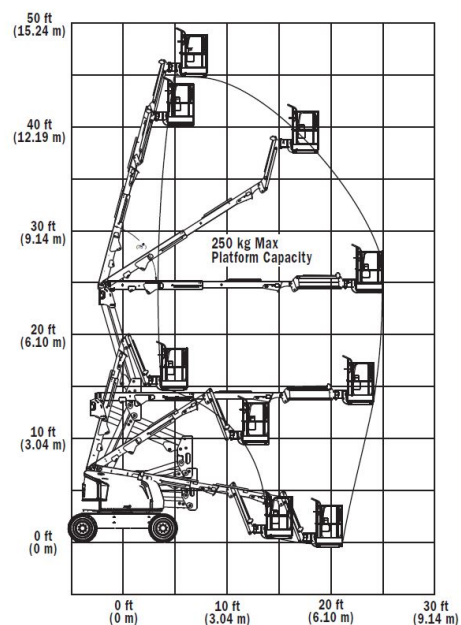

The JLG "1&5" Warranty

JLG Industries, Inc. backs its products with its exclusive "1 & 5" Warranty. We provide coverage on all products for one (1) full year and cover all specified major structural components for five (5) years. Due to continuous product improvements we reserve the right to make specification and/ or equipment changes without prior notification. This machine meets or exceeds AS/NZS 1418.11 2011 as originally manufactured for intended application

AUSLIFT
EQUIPMENT

JLG

Auslift Equipment Pty. Ltd. (Australia)

Factory 2/2-4 Souffi Place,
Dandenong South, Vic 3175
T: 03 9702 7977
www.auslift.com.au