

340AJ

ARTICULATING BOOM LIFT



Performance

Platform Height	10.33 m
Working Height	12.33 m
Horizontal Outreach	6.06 m
Up and Over Clearance	5.17 m
Swing	355 Degrees Non-Continuous
Platform Capacity	230 kg
Platform Size	0.76 x 1.52 m
Platform Rotator	180 Degrees Hydraulic
Jib	1.22 m
Jib Range of Articulation	144 Degrees (+84, -60)
Weight	4,400 kg
Drive Speed	4.98 km/h
Gradeability	45%
Turning Radius	
Outside	3.96 m
Inside	1.52 m

Standard Specifications

Power Source

Diesel Engine	Kubota D1105
Fuel Tank Capacity	49.2 L

Hydraulic System

Capacity	77.9 L
Auxiliary Power	12V-DC

Tyres

Standard	18 x 7 Non-marking Solid Flex Cushion
----------	---------------------------------------

Standard Features

- 4WD
- 180 Degree Hydraulic Platform Rotator
- Platform Console Machine Status Light Panel*
- 3 Degree Tilt Alarm/Indicator Light
- Swing Out Engine Tray
- 12V-DC Auxiliary Power
- Hourmeter
- Proportional Controls
- Control ADE® System
- Lifting/Tie Down Lugs
- Horn
- Four-Wheel Hydrostatic Drive
- Oscillating Axle
- Operator Tool Tray
- Inward Self-Closing, Self-Locking Swing Gate
- Flashing Amber Beacon
- Motion Alarm
- Glow Plugs (Diesel Engines)

* Provides indicator lights at platform control console for system distress, low fuel, 5 degree tilt light, and foot switch status.



Accessories & Options

- 0.76 x 1.22 m Platform
- 1/2 in. Air Line to Platform
- AC Generator including AC Outlets to Platform
- Light Package
- Platform Worklights
- Mesh to Mid-Rail
- Special Hydraulic Oils (Consult Factory)
- White Noise (Squawker) Motion Alarm
- Accessory Packages
 - SkyGuard®
 - Pipe Rack
 - ClearSky®

Note: Some options may increase lead time, and some option combinations may not be available.

340AJ

ARTICULATING BOOM LIFT



Dimensions

All dimensions are approximate.

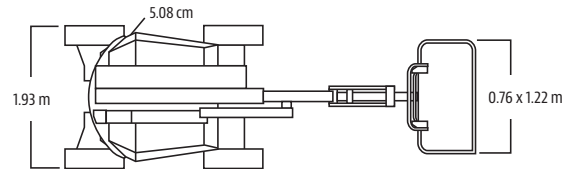
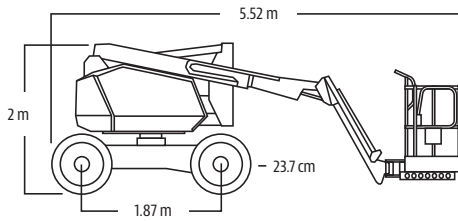

Reach Diagram

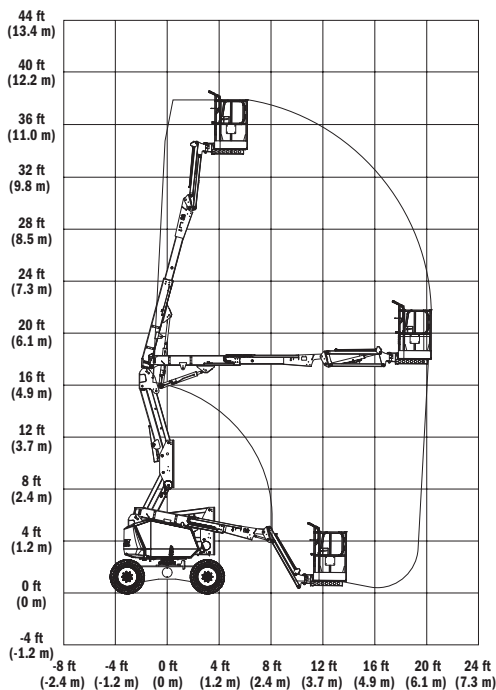

The JLG "1 & 5" Warranty

JLG Industries, Inc. backs its products with its exclusive "1 & 5" Warranty. We provide coverage on all products for one (1) full year and cover all specified major structural components for five (5) years. Due to continuous product improvements, we reserve the right to make specification and/or equipment changes without prior notification. This machine meets or exceeds AS/NZS 1418.10 2011 as originally manufactured for intended applications.



JLG Industries (Australia)

358 Park Road
 Regents Park, NSW 2143
 Telephone 02 8718 6300
 Fax 02 8718 6377
www.jlg.com.au

An Oshkosh Corporation Company