

3369LE

AUSLIFT
EQUIPMENT



BI-ENERGY SCISSOR LIFT

Performance

Platform Height	10.06 m
Capacity with Dual Extensions	450 kg
Capacity on Platform Extension	120 kg
Lift/Lower Time	38/42 sec
Maximum Drive Height	Full Height
Weight	4,600 kg
Drive Speed (Lowered)	4.8 km/h
Drive Speed (Raised)	0.64 km/h
Gradeability	2WD 35%
Turning Radius (Inside)	2.29 m
Turning Radius (Outside)	4.90 m

Standard Specifications

POWER SOURCE

Batteries	8 x 6V, 370 amp/hr
Charger	20 Amp, Auto SCR Charger
Electric Pump Motor	Series Wound
Drive Motors	Two 5.5 hp Stunt Wound
Engine Fuel Tank Capacity	15.14 L

HYDRAULIC SYSTEM

Capacity	121.42
Pump	Single Section Gear Pump

TYRES

Standard	240/55-17.5 Foam Filled
----------	-------------------------

Standard Features

- 1.65 x 2.92 m Work Platform
- Full Time ATC – JLG Automatic Traction Control System
- Oscillating Axle
- Proportional Direct DC Electric Drive
- Proportional Lift Up
- On- Board Diagnostics with Common JLG Analyzer
- Movable, Removable Platform Console Box
- Battery Charge Indicator in Platform
- 3 Degree Tilt Indicator Light and Alarm
- All Motion Alarm
- Manual Descent
- LSSS

Accessories & Options

- AC Outlet to Platform including ELCB
- Wheel Chocks
- Squawker / White Noise Motion Alarm
- Platform Work lights



DIMENSIONS

All dimensions are approximate.

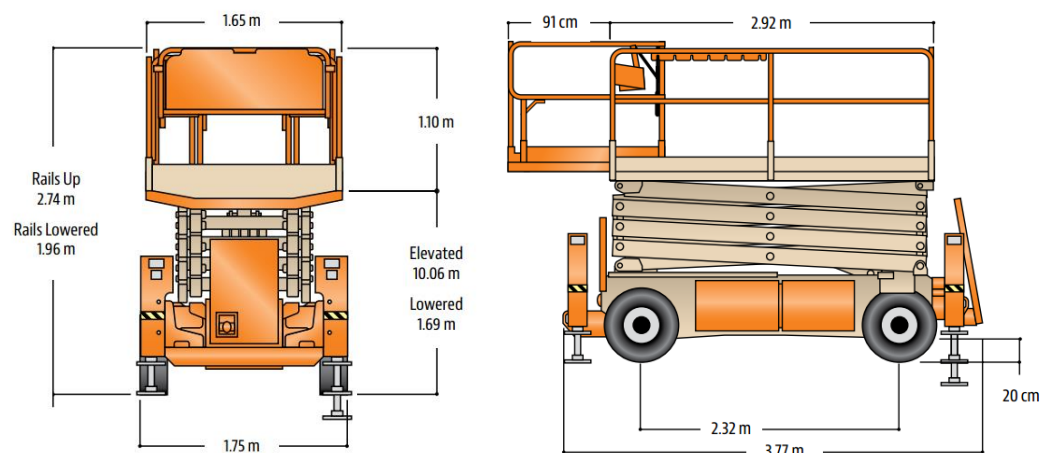

The JLG "2&5" Warranty

JLG Industries, Inc. backs its products with its exclusive "2&5" Warranty. We provide coverage on all products for two (2) full years and cover all specified major structural components for five (5) years. Due to continuous product improvements, we reserve the right to make specifications and/or equipment changes without prior notification. This machine meets or exceeds AS/NZS 1418.10 2011 as originally manufactured for intended applications

Distributed by:

Auslift Equipment

2/2-4 Souffi Place

Dandenong South, Vic. 3175

Telephone: 03 9702 7977

Email: sales@auslift.com.au

Website: www.auslift.com.au

AUSLIFT
EQUIPMENT