

1250APJ

ARTICULATING BOOM LIFT

Performance

Platform Height	38.30 m
Working Height	40.30 m
Horizontal Outreach	19.25 m
Up and Over Height	18.44 m
Weight	21,000 kg
Swing	360° Non-Continuous
Platform Capacity - Restricted	450 kg
Platform Capacity - Unrestricted	230 kg
Platform Rotator	180° Hydraulic
Jib	2.44 m
Horizontal Motion / Vertical Motion	125° / 130° (+75°, -55°)
Drive Speed Lowered / Elevated	5.2 / 0.5 km/h
Gradeability	45%
Turning Radius Inside (Retracted/Extended)	4.39 / 2.44 m
Turning Radius Outside (Retracted/Extended)	6.86 / 5.89 m

Standard Specifications

Power

Diesel Engine	Deutz TD2011LO40 T4I, 55kW
Fuel Tank Capacity	117 L

Tyres

Standard	445/50D710 24 Urethane-Filled
----------	-------------------------------

Hydraulic System

Capacity	202 L
----------	-------

Dimensions

All dimensions are approximate

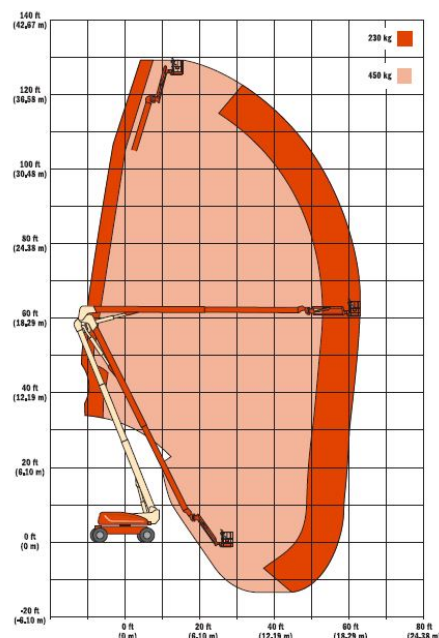
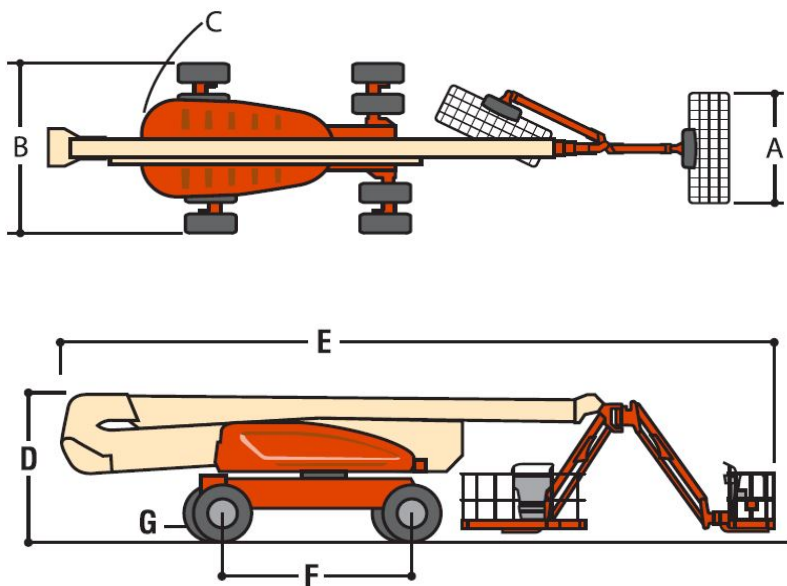

AUSLIFT
EQUIPMENT

JLG

Standard Features

- Platform 0.91 x 2.44 m
- 2.44 m
- JibPLUS® Boom
- Selectable Capacity Envelope
- 180° Hydraulic Platform Rotator
- AC Receptacle in the Platform
- 5.5KVA Generator
- 1/2 in. Air Line to Platform
- 5 x 3 Degree Tilt Alarm/Indicator Light
- All Motion Alarm
- Swing-Out Engine Tray
- 12V DC Auxiliary Power
- Engine Distress Warning/Shutdown – Selectable via JLG Analyzer
- Control ADE® System
- Full-time 4WD
- 3 Selectable Steering Modes
- Drive-out Extendable Axles
- Oscillating Axle
- Proportional Controls
- Gull-Wing Hoods
- 445/50D710 Urethane-Filled Rim Protector Lug Tread Tyres
- Inward Self-Closing, Self Locking Swing Gate
- Lifting/Tie Down Lugs
- Hourmeter

Accessories & Options

- 0.91 x 1.83 m Platform
- Mesh to Mid Rail
- Special Hydraulics Oils (Consult Factory)
- Skyguard
- Platform Worklights
- Pipe Racks
- Cable Ladder Carrier
- Corner Storage Tray
- ClearSky®



The JLG "1&5" Warranty

JLG Industries, Inc. backs its products with its exclusive "1 & 5" Warranty. We provide coverage on all products for one (1) full year and cover all specified major structural components for five (5) years. Due to continuous product improvements we reserve the right to make specification and/ or equipment changes without prior notification. This machine meets or exceeds AS/NZS 1418.11 2011 as originally manufactured for intended application

AUSLIFT
EQUIPMENT

JLG

Auslift Equipment Pty. Ltd. (Australia)
Factory 2/2-4 Souffi Place,
Dandenong South, Vic 3175
T: 03 9702 7977
www.auslift.com.au