

TRAILER-MOUNTED BOOMS

AUSLIFT
EQUIPMENT



HTA13 P - HTA16 P
HTA19 P - HTA22 P
HTT13

Access on the move:

- Hydraulic outriggers and automatic leveling allow operation in under 30 seconds
- Superior combination of industry leading capacity and outreach
- Can be towed by a standard half-ton pickup truck - No commercial driver's license needed

Exceptional productivity

- Air / water lines and 110V GFI protected power to the platform



HTT13

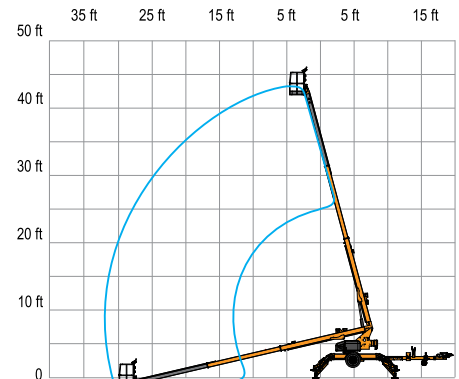

HTA22 P - HTA22 P - HTA22 P - HTA22 P

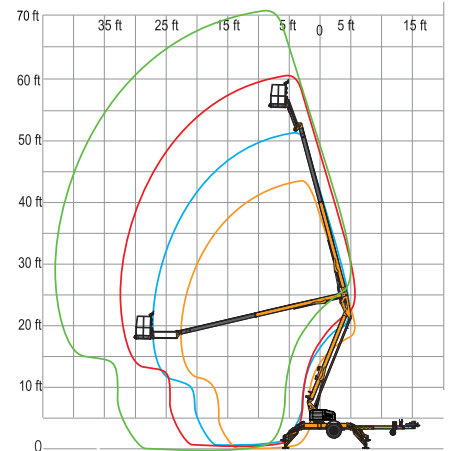

Haulotte 
GROUP

www.auslift.com.au



HTA13 P - HTT13 - HTA16 P - HTA19 P - HTA22 P

TRAILER-MOUNTED BOOMS

TECHNICAL DATA

HTA13 P HTT13 HTA16 P HTA19 P HTA22 P

Working height	12.73 m	13.26 m	15.54 m	18.67 m	21.64 m
Platform height	10.9 m	11.43 m	13.72 m	16.84	19.81 m
Horizontal outreach (from centerline)	6.86 m	9.75 m	8.23 m	10.19 m	13.1 m
Horizontal outreach (from edge of footpad)	5.31 m	8.23 m	6.40	8.33 m	11.27 m
Up and over height	5.79 m	N/A	6.33 m	7.04 m	7.4 m
Lift capacity	227 kg				
A - Length - stowed	4.96 m	6.68 m	5.94 m	6.99 m	7.31 m
B - Width stowed	1.67 m		1.7		1.8 m
C - Height stowed	1.96 m		1.98 m		2.13 m
D x E - Platform size	1.22 X 0.76				
F - Widest Point	3.6 m	4.19 m	4.19 m	4.47 m	4.46 m
G - Widest Point	3.4 m	4.11 m	4.11 m	4.57 m	4.58 m
Turntable rotation	350° non-continuous				
Jib - length	1.3 m	N/A	1.3 m		
Jib - Vertical motion	150° (+70 / -80)	N/A	150° (+70 / -80)		
Tow speed rating	104.6 km/h				
Leveling capability	12.5 °				
Tire size	ST 225/75 D15		ST 225/75 R15		ST 215/75R 17.5
Power source	4 x 6 V 245 amp-hr				
Tongue weight (no options)	111 kg	91 kg	132 kg	152 kg	250 kg
Weight (no options)	1542 kg	2014 kg	1905 kg	2177 kg	3500 kg

STANDARD EQUIPMENT

- Hydraulic outriggers
- Tilt alarm/sensor
- Hour meter and battery condition indicator
- Automatic leveling system and self-leveling platform
- 110V GFI protected outlet to platform
- Easy to use controls
- Air and water line to platform
- Inboard 25 amp charger
- Integrated forklift pockets
- Hydraulic surge brakes (trailer)

OPTIONS & ACCESSORIES

- Spare tire and mounting kit
- DC / Gas hybrid
- Manual platform rotator - 120° stop point to stop point
- Flashing beacon
- Fluorescent tube caddy
- Combination hitch
- Tool tray
- Electric brakes (trailer)
- Drive and Set

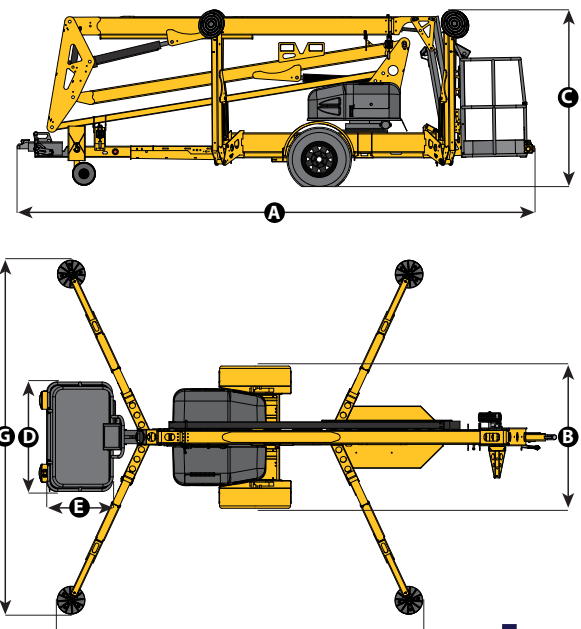
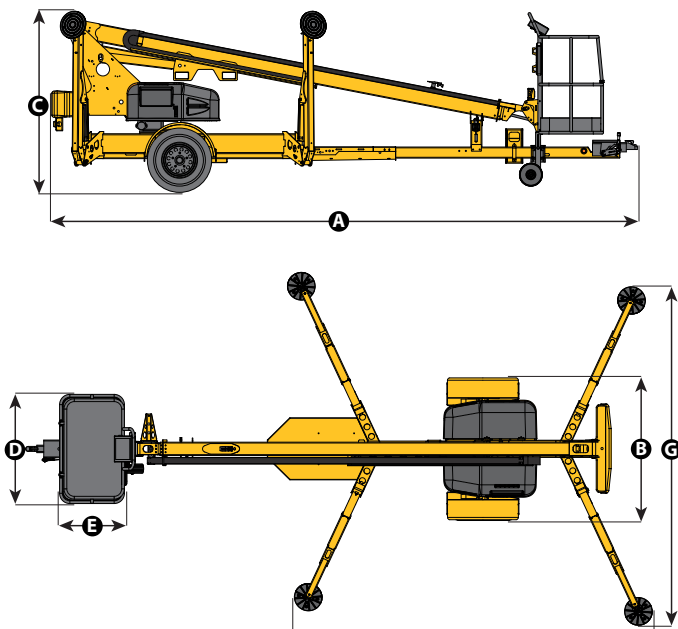

Distributed by:

Auslift Equipment
 2/2-4 Souffi Place
 Dandenong South, Vic. 3175
 Telephone: 03 9702 7977
 Email: sales@auslift.com.au
 Website: www.auslift.com.au