



A wide range of machines to meet your every need

- Working heights from 7 to 14 m
- 2 available versions supply-power (AC) or batteries (DC)

The Quick-Up will follow you on every project

- Easy to transport on a trailer or van
- Only one person is needed to install a Quick Up
- The light weight enables use on fragile grounds, tiles, carpeting...
- Quick up are extremely compact, they can access the tightest spaces, fit through standard doorways and can be transported in lifts

AUSLIFT
EQUIPMENT

Haulotte



QUICK-UP 7 / 8 / 9 / 11 / 12 / 13 / 14

PUSH AROUND BOOMS

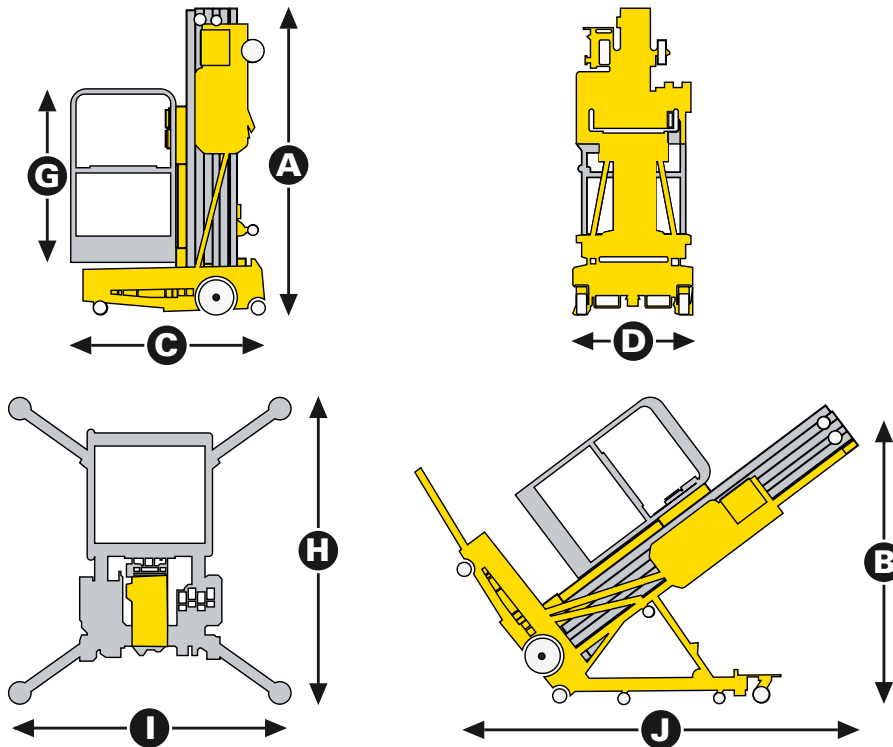

TECHNICAL DATA

	QUICK-UP 8	QUICK-UP 11	QUICK-UP 12	QUICK-UP 14
Working height	8.1 m	10.8 m	12.3 m	14.3 m
Platform height	6.1 m	8.8 m	10.3 m	12.3 m
Lift capacity	159 kg	159 kg	136 kg	136 kg
Platform size	0.68 x 0.66 m	0.68 x 0.66 m	0.68 x 0.66 m	0.68 x 0.66 m
C Length	1.28 m	1.34 m	1.4 m	1.42 m
D Width	0.8 m	0.8 m	0.8 m	0.8 m
A Height - stowed	1.98 m	1.98 m	1.98 m	2.8 m
I Width - stabilised	1.55 m	1.55 m	2.06 m	2.33 m
H Length - stabilised	1.75 m	1.75 m	2.26 m	2.58 m
J x B Tilt bar	N/A	N/A	N/A	2.85 x 1.99 m
Energy (AC)	110 or 230 V	110 or 230 V	110 or 230 V	110 or 230 V
Weight (AC)	340 kg	380 kg	415 kg	515 kg
Energy (DC)	12 V	12 V	12 V	12 V
Weight (DC)	382 kg	422 kg	457 kg	557 kg

STANDARD EQUIPMENT

- Push button controls for easy operation
- Emergency control
- Manual platform lowering valve
- Integrated forklift pockets
- Lifting eye
- Non marking wheels
- Harness attachment point
- Lights on control box to confirm stabilizers are set

OPTIONS AND ACCESSORIES

- AC powered

Distributed by:

Auslift Equipment
 2/2-4 Souffi Place
 Dandenong South, Vic. 3175
 Telephone: 03 9702 7977
 Email: sales@auslift.com.au
 Website: www.auslift.com.au