



COMPACT 14



Exceptional productivity

- Working height up to 13.85m
- Driveable at full height
- Load capacity: 350 kg
- Robust, reliable, easy to maintain
- Extended platform
- Long working cycles

Optimum compactness

- 1.2m width
- Folding guardrails



AUSLIFT
EQUIPMENT

Haulotte 
GROUP



COMPACT 14

ELECTRIC SCISSOR LIFTS

350 kg / 3x
 770 lbs

TECHNICAL DATA

COMPACT 14

Working height	13.85 m
Platform height	11.85 m
Lift capacity	350 kg
A Platform length - outside	2.31 m
Platform length - extended	3.23 m
Length - extension	0.92 m
Platform width - outside	1.2 m
D Storage height	2.08 m
C Height - stowed	2.5 m
B Overall width	1.2 m
E Length	2.49 m
F Wheelbase	1.86 m
G Ground clearance - Center	13 cm
Ground clearance - Deployed potholes	2.3 cm
Drive speed	0.9 - 2.7 km/h
Driveable at full height up to	11.85 m
Gradeability	23 %
Tilt	2° / 3°
Lift / lower speed	61 s / 50 s
Turning radius - outside	2.5 m
Non-marking tyres	15 x 5
Batteries	24 V - 340 Ah (C20)
Hydraulic system capacity	25 l
Weight	3 175 kg

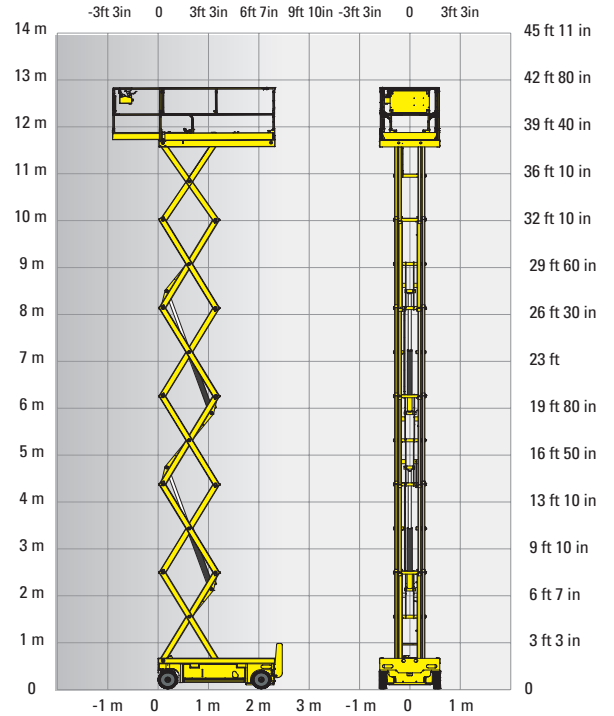

STANDARD EQUIPMENT

- Pothole guards
- Battery charge indicator
- Proportional lift and drive
- Removable control box in platform
- Swing out component tray
- Battery charger with automatic stop
- Solid non-marking tyres
- Brake release
- Tilt controller
- Load Management System in the platform
- Manual platform lowering valve
- Integrated forklift pockets
- Towing hooks
- Horn
- Hourmeter

OPTIONS AND ACCESSORIES

- Flashing light
- Travel alarm
- Working light
- Power to platform
- Biodegradable hydraulic oil
- Centralised battery filling

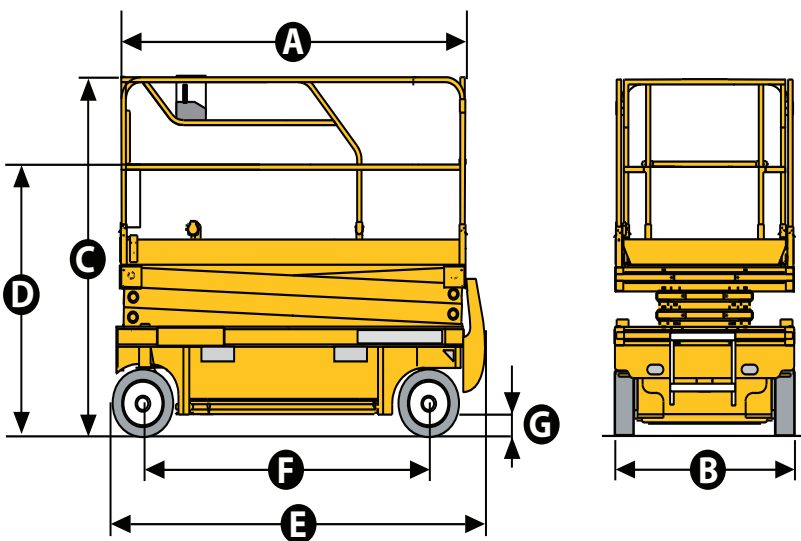

We reserve the right to modify the technical characteristics of this document without notice - 10/2016