



Outstanding rough terrain driving features

- 4 wheel drive
- Automatic differential lock
- Excellent gradeability (40%)
- Ground clearance of 28 cm

Robust and easy to maintain

- Outriggers positioned within the machine footprint
- Durable and reliable upper control box
- Optimized accessibility to components
- Built-in diagnosis tool

Exceptional productivity

- Full proportional controls
- Narrow turning radius
- One switch to deploy and retract 4 outriggers



AUSLIFT
EQUIPMENT

Haulotte 
GROUP



COMPACT 12 DX

ROUGH TERRAIN SCISSOR LIFTS

AUSLIFT
EQUIPMENT

Haulotte
GROUP

TECHNICAL DATA

Compact 12 DX

Working height	12.06 m
Platform height	10.06 m
Lift capacity	450 kg
A Length	3.17 m
B Width	1.78 m
C Height - stowed	2.56 m
Storage height	1.7 m
F Platform length	2.45 m
Extended platform length	3.7 m
Platform extension length	1.2 m
G Platform width	1.45 m
D Wheelbase	1.84 m
E Ground clearance	28 cm
Number of extensions	1
Drive speed	0,8 - 5,5 km/h
Turning radius - outside	3.5 m
Lift / lower speed	35 s / 51 s
Engine	18.5 kW - 24.8 hp
Gradeability	40 %
Tires - foam-filled	26x12-16.5
Hydraulic system capacity	75 l
Weight	4 110 kg

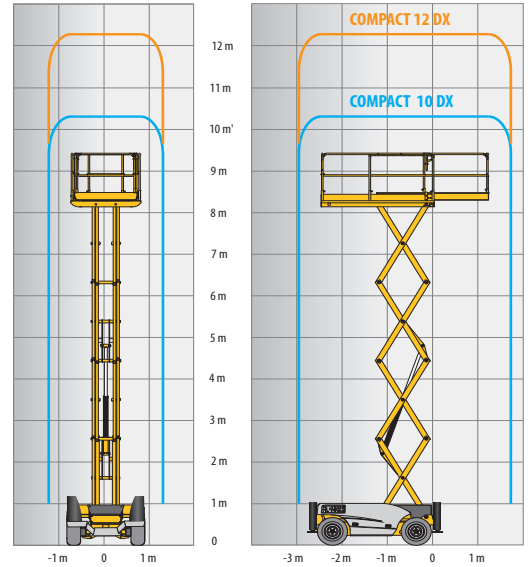
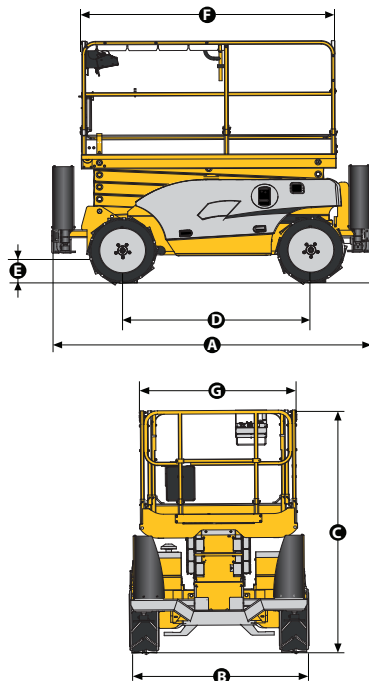

STANDARD EQUIPMENT

- Kubota engine
- 4 wheel drive, 2 wheel steer
- 3° Tilt alarm
- 1,2m platform extension
- 12V - 74 Ah Batteries
- Removable operator's control box
- Brake release
- Hourmeter
- Towing hooks
- Hydraulic brakes
- Manual platform lowering valve
- Foam filled all terrain tyres
- Automatic levelling outriggers
- Side shields
- Horn
- Lanyard attachment points
- Swing-door gate

OPTIONS AND ACCESSORIES

- Non marking tyres
- Rotating beacon
- 240 V power to the platform
- Travel alarm
- Motion alarm for movements and translation
- Working light
- Biodegradable oil
- Cold Weather Package
- Foldable guard-rails
- Hydraulic generator 3.5 kW

Non contractual document - We reserve the right to modify the technical characteristics of this document without notice - 10/2016



AUSLIFT
EQUIPMENT

Auslift Equipment
2/2-4 Souffi Place, Dandenong South.
Vic.3175 Email: sales@auslift.com.au

Telephone : 03 9702 7977
Website:
www.auslift.com.au