



COMPACT 8

COMPACT 10N

Optimum compactness

- Width of 81 cm to operate in the most congested areas
- Compact stowed height for easy access through standard doorways

Exceptional productivity

- Load capacity up to 350 kg (Compact 8)
- Driveable at full height
- Extended platform
- Long working cycles

Reliable, easy to maintain



AUSLIFT
EQUIPMENT

Haulotte 
GROUP



COMPACT 8 / COMPACT 10N

ELECTRIC SCISSOR LIFTS

AUSLIFT
EQUIPMENT

Haulotte
GROUP

TECHNICAL DATA

COMPACT 8

COMPACT 10N

Working height	8.2 m	10 m
Platform height	6.2 m	8 m
Driveable at full height up to	6.2 m	8 m
Lift capacity - inside	350 kg	230 kg
Lift capacity - outside	120 kg	N/A
A Platform length - outside	2.31 m	2.31 m
B Platform length - extended	3.23 m	3.23 m
Length - extension	0.92 m	0.92 m
C Platform width - outside	0.81 m	0.81 m
E Storage height	1.13 m	1.32 m
D Height - stowed	2 m	2.18 m
F Overall width	0.81 m	0.81 m
G Length	2.49 m	2.49 m
H Wheelbase	1.86 m	1.86 m
I Ground clearance - Center	13 cm	13 cm
Ground clearance - Pothole guards deployed	2.5 cm	2.5 cm
Drive speed	1 - 3.3 km/h	1 - 3.2 km/h
Gradeability	23 %	23 %
Tilt	2 °	2 °
Lift / lower speed	26 s / 37 s	36 s / 42 s
Turning radius - outside	2.38 m	2.38 m
Non-marking tires	15x5	15x5
Batteries	24 V - 225 Ah (C20)	24 V - 225 Ah (C20)
Hydraulic system capacity	27 l	27 l
Weight	1 655 kg	2 190 kg

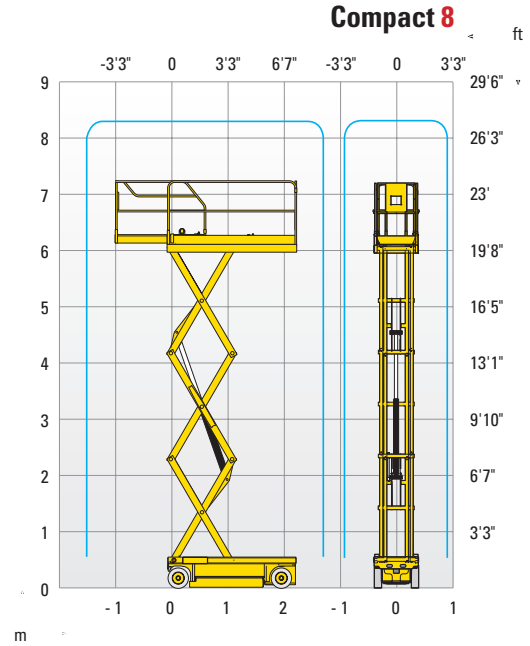
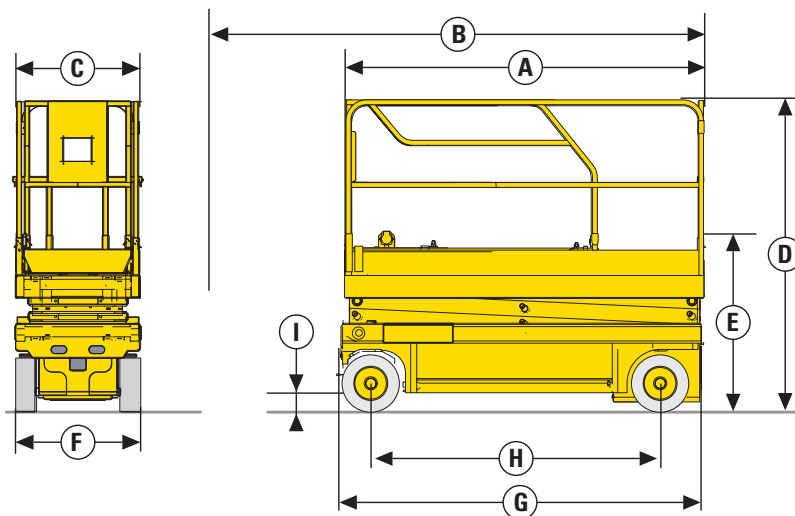

STANDARD EQUIPMENT

- Pothole guards
- Battery charge indicator
- Proportional lift and drive
- Folding handrails (C10N)
- Swing out component tray
- Battery charger with automatic stop
- Solid non-marking tyres
- Free wheeling device
- Tilt controller
- Load Management System in the platform
- Manual platform lowering valve
- Integrated forklift pockets
- Towing hooks
- Horn
- Hourmeter

OPTIONS AND ACCESSORIES

- Flashing light
- Travel alarm
- Working light
- Power to platform
- Biodegradable hydraulic oil
- Folding guardrails (C8)
- Centralised battery filling

AUSLIFT
EQUIPMENT

Auslift Equipment
2/2-4 Souffi Place, Dandenong South. Vic.3175
Email: sales@auslift.com.au

Telephone : 03 9702 7977
Website: www.auslift.com.au