



**Optimal productivity**

- Continuous 360° turntable rotation
- Full proportional controls and simultaneous boom functions
- Lifts to full height in 44 seconds

**Outstanding rough terrain driving features**

- 4 wheel steer and 4 wheel drive mean greater manoeuvrability
- Hydraulic differential lock
- 40cm ground clearance

**10.6 m outreach provides a large working envelope**





# HA18 PX

ROUGH TERRAIN ARTICULATING BOOMS

## TECHNICAL DATA

## HA18 PX

Working height	17.2 m
Platform height	15.2 m
Horizontal outreach	10.6 m
Up and over clearance	6.6 m
Lift capacity	230 kg
<b>F x G</b> Platform size	1.8 x 0.8 m
<b>A</b> Length - stowed	7.6 m
Transport length	5.9 m
<b>B</b> Width	2.3 m
<b>C</b> Height - stowed	2.3 m
Transport height	2.6 m
Vertical jib rotation	140° (+70/-70)
Platform rotation	178° (+89/-89)
Turntable rotation	360°
Tailswing	0 m
<b>D</b> Wheelbase	2 m
<b>E</b> Ground clearance	40 cm
Tilt	5°
Drive speed	0.8 - 5.5 km/h
Gradeability	50 %
Turning radius - outside	3.75 m
Tires - foam-filled	385/65-22.5
Power source	31 kW - 42 hp
Hydraulic system capacity	100 l
Fuel tank capacity	75 l
Weight	8050 kg

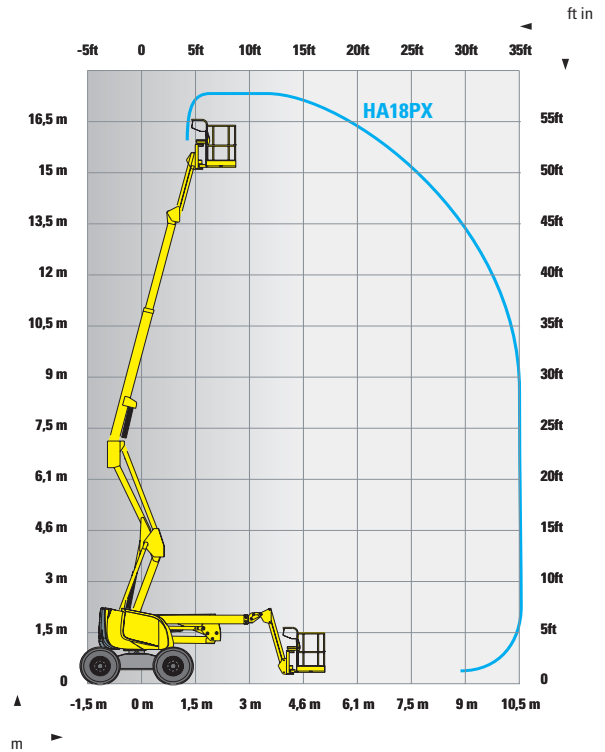

## STANDARD EQUIPMENT

- 4 wheel drive and steer
- Continuous 360° turntable
- Safe to use in winds up to 60km/h
- Swing out engine tray for ease of maintenance
- 75 l fuel tank; 1.50 m filling height
- 5° tilt alarm
- 12 V battery / electrical control system
- Auxiliary power in the platform for emergency descent
- Brake release
- Hourmeter
- Slewing block pin
- Towing hooks / lifting eyes

## OPTIONS AND ACCESSORIES

- 4.1 kW on-board generator
- Power to platform
- Large basket 2.3 x 0.80 m (safe to use in winds up to 45 km/h – 28 mph).
- Travel alarm
- Rotating beacon
- Working light
- Catalytic exhaust
- Biodegradable hydraulic oil
- Cold Weather Package
- Warm environment kit
- Air line in platform

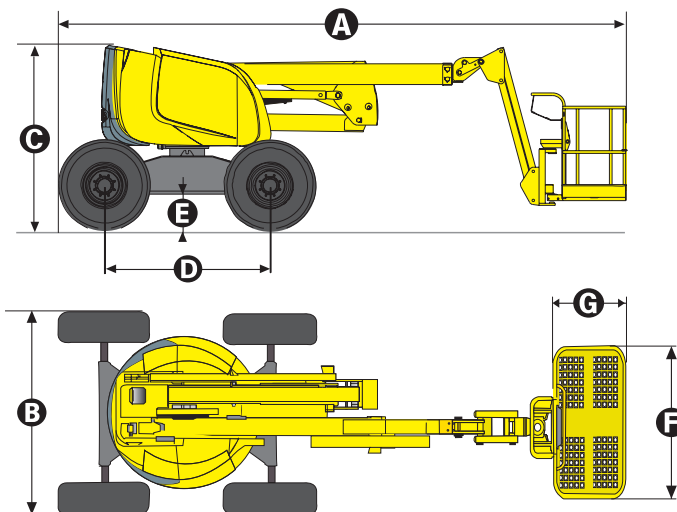

Distributed by: **Auslift Equipment**  
 2/2-4 Souffi Place  
 Dandenong South. Vic. 3175  
 Telephone: 03 9702 7977  
 Email: sales@auslift.com.au  
 Website: www.auslift.com.au