



COMPACT 10 RTE COMPACT 12 RTE



Oustanding performance, both inside and outside

- Suitable for all terrains allowing the operator to work without noise and fumes
- Tight turning radius allowing an excellent manoeuvrability in confined areas
- Foam filled and non-marking tires with rough terrain profile
- Ground clearance of 25 cm
- Load capacity up to 565 kg (C10 RTE)
- Driveable at full height (C10 RTE)
- Long working cycles

Robust, reliable, easy to maintain

AUSLIFT
EQUIPMENT

Haulotte



COMPACT 10/12 RTE

ELECTRIC SCISSOR LIFTS

AUSLIFT
EQUIPMENT

Haulotte

TECHNICAL DATA

Compact 10 RTE

Compact 12 RTE

Working height	10.28 m	12.06 m
Platform height	8.28 m	10.06 m
Maximum drive height	8.28 m	8.28 m
Lift capacity - inside	565 kg (3 pers.)	450 kg (3 pers.)
Lift capacity - outside	565 kg (3 pers.)	450 kg (3 pers.)
Lift capacity on the extension	150 kg	150 kg
Platform length - outside	2.45 m	2.45 m
Platform length - extended	3.7 m	3.7 m
Length - extension	1.2 m	1.2 m
G Platform width - outside	1.45 m	1.45 m
Storage height	1.59 m	1.71 m
C Height - stowed	2.44 m	2.56 m
B Overall width	1.78 m	1.78 m
A Length	2.64 m	2.64 m
D Wheelbase	1.84 m	1.84 m
E Ground clearance - Deployed potholes	N/A	N/A
Drive speed	0,8 - 5,8 km/h	0,8 - 5,8 km/h
Gradeability	25 %	25 %
Tilt	3 °	3 °
Lift / lower speed	35 s / 35 s	43 s / 43 s
Turning radius - outside	3.73 m	3.73 m
Non-marking tires	26x12-12	26x12-12
Batteries	48 V - 255 Ah (C5)	48 V - 255 Ah (C5)
Hydraulic system capacity	63 l	63 l
Weight	3 305 kg	3 675 kg

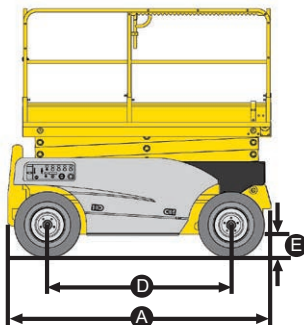
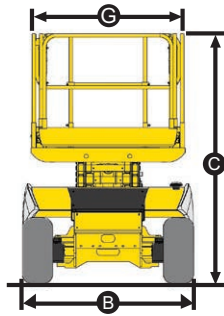

Compact 12 RTE

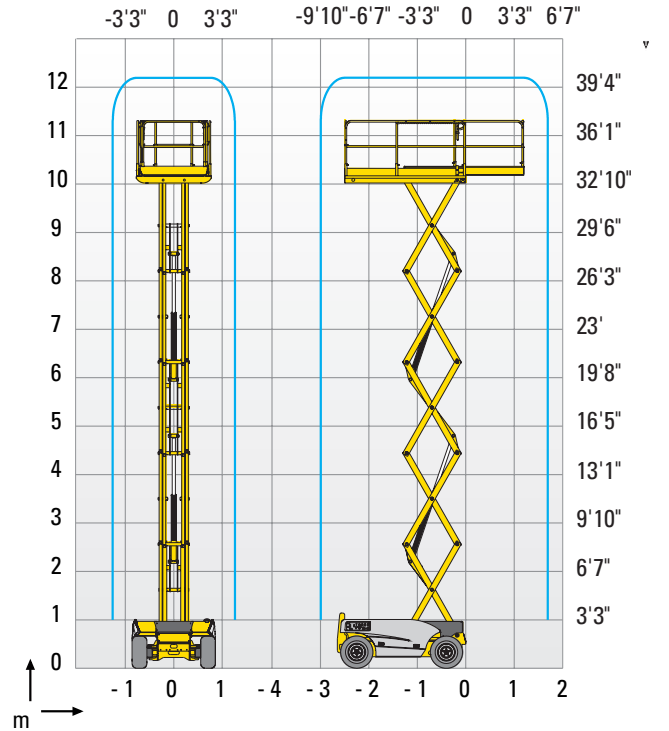

STANDARD EQUIPMENT

- Extended platform
- Horn
- Towing hooks
- Hydraulic brakes
- Manual platform lowering valve
- Load Management System in the platform
- Tilt controller
- Free wheeling device
- 2 wheel-drive
- Lanyard attachment points
- Battery charger with automatic stop
- Battery charge indicator
- Removable control box in platform
- Proportional lift and drive
- Hourmeter

OPTIONS AND ACCESSORIES

- Flashing light
- Travel alarm
- Power to platform
- Biodegradable hydraulic oil
- Outriggers (Increase machine weight by 240 kg)

AUSLIFT
EQUIPMENT

Auslift Equipment
2/2-4 Souffi Place, Dandenong South. Vic.3175
Email: sales@auslift.com.au

Telephone : 03 9702 7977
Website: www.auslift.com.au