

## Specifications

Models	GS-2669 DC		GS-3369 DC		GS-4069 DC	
Measurements	Metric	US	Metric	US	Metric	US
Working height maximum*	9.70 m	31 ft 3 in	11.75 m	38 ft	14.12 m	45 ft 9 in
▲ Platform height maximum	7.70 m	25 ft 3 in	9.75 m	32 ft	12.12 m	39 ft 9 in
Drive height	7.70 m	25 ft 3 in	9.75 m	32 ft	12.12 m	39 ft 9 in
▲ Platform height - stowed	1.47 m	4 ft 10 in	1.47 m	4 ft 10 in	1.65 m	5 ft 5 in
▲ Platform length - outside	2.79 m	9 ft 2 in	2.79 m	9 ft 2 in	2.79 m	9 ft 2 in
extended	4.32 m	14 ft 2 in	4.32 m	14 ft 2 in	4.32 m	14 ft 2 in
Slide-out platform extension deck	1.52 m	5 ft	1.52 m	5 ft	1.52 m	5 ft
▲ Platform width - outside	1.60 m	5 ft 3 in	1.60 m	5 ft 3 in	1.60 m	5 ft 3 in
Toeboard height	0.15 m	6 in	0.15 m	6 in	0.15 m	6 in
▲ Height - stowed	2.59 m	8 ft 6 in	2.59 m	8 ft 6 in	2.74 m	9 ft
rails lowered	1.92 m	6 ft 3.5 in	1.92 m	6 ft 3.5 in	2.08 m	6 ft 10 in
▲ Length - stowed	3.76 m	12 ft 4 in	3.76 m	12 ft 4 in	3.76 m	12 ft 4 in
platform extended	4.81 m	15 ft 9.5 in	4.81 m	15 ft 9.5 in	4.81 m	15 ft 9.5 in
▲ Width	1.75 m	5 ft 9 in	1.75 m	5 ft 9 in	1.75 m	5 ft 9 in
▲ Wheelbase	2.29 m	7 ft 6 in	2.29 m	7 ft 6 in	2.29 m	7 ft 6 in
▲ Ground clearance - center	0.24 m	9.5 in	0.24 m	9.5 in	0.24 m	9.5 in

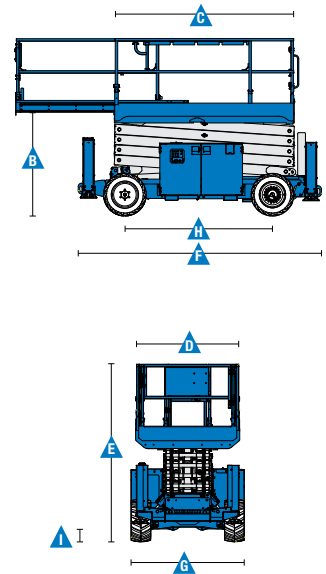

## Productivity

Maximum platform occupancy**	4		4		3	
Lift capacity	680 kg	1,500 lbs	454 kg	1,000 lbs	363 kg	800 lbs
Extension deck capacity	136 kg	300 lbs	136 kg	300 lbs	136 kg	300 lbs
Drive speed - stowed	7.2 km/h	4.5 mph	7.2 km/h	4.5 mph	7.2 km/h	4.5 mph
Drive speed - raised	0.5 km/h	0.3 mph	0.5 km/h	0.3 mph	0.5 km/h	0.3 mph
Gradeability - stowed***	35%		35%		35%	
downhill stowed***	15%		15%		15%	
Maximum outrigger leveling:						
front/back uphill			5.3° / 4.2°			
side to side			11.7°			
Turning radius - inside	2.11 m	83 in	2.11 m	83 in	2.11 m	83 in
Turning radius - outside	4.6 m	181.2 in	4.6 m	181.2 in	4.6 m	181.2 in
Raise/lower speed	34/31 sec		39/29 sec		61/28 sec	
Controls	Proportional Drive / 2 Speed Lift					
Tyres - rough terrain	30x66 cm	12x26 in	30x66 cm	12x26 in	30x66 cm	12x26 in

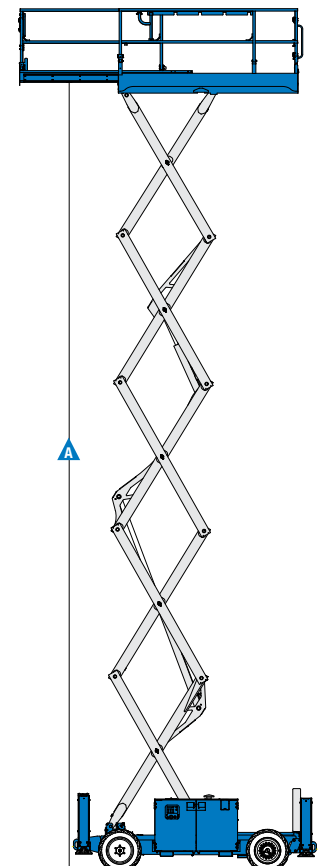

## Power

Power source	48V DC (eight 6V batteries, 225 Ah Capacity)		48V DC (eight 6V batteries, 225 Ah Capacity)		48V DC (eight 6V batteries, 315 Ah Capacity)	
Hydraulic system capacity	68.1 L	18 gal	68.1 L	18 gal	68.1 L	18 gal

## Weight\*\*\*\*

	4,002 kg	8,822 lbs	3,885 kg	8,563 lbs	5,329 kg	11,747 lbs
--	----------	-----------	----------	-----------	----------	------------

## Standards Compliance

ANSI A92.6, CSA B354.2, CE Compliance, AS 1418.10

\* The metric equivalent of working height adds 2 m to platform height. U.S. Adds 6 ft to platform height.

\*\* CE/AUS markets: GS™-3369 and GS™-4069 are limited to 2 person platform occupancy when used outdoors.

\*\*\* Gradeability applies to driving on slopes. Gradeability may vary depending on the weight of options installed on machine. See operator's manual for details regarding slope ratings.

\*\*\*\* Weight varies depending on options and country standards.

### Features

#### Standard Features

##### Measurements

###### GS™-2669 DC

- 9.70 m (31 ft 3 in) working height
- Up to 680 kg (1,500 lb) lift capacity

###### GS™-3369 DC

- 11.75 m (38 ft) working height
- Up to 454 kg (1,000 lb) lift capacity

###### GS™-4069 DC

- 14.12 m (45 ft 9 in) working height
- Up to 363 kg (800 lb) lift capacity

##### Productivity

- 2.79 x 1.6 m (110 x 63 in) steel frame platform with replaceable aluminum deck
- 1.52 m (5 ft) extension deck
- Automatic leveling hydraulic outriggers
- Folding guardrails
- Proportional drive and two speed lift
- AC sealed brushless drive motors
- Full height swing gate
- 2WD
- Front oscillating axle
- Positive traction control
- Regenerative braking
- Non-marking, rough terrain tyres 30 x 66 cm (12 x 26 in)
- Tilt level sensor with audible alarm
- Descent alarm
- Horn
- Hour meter
- Dual flashing beacons
- Motion alarm

##### Power

- 48 V DC (eight 6V batteries)

#### Options & Accessories

##### Productivity

- Air line to platform
- 240 Volt power to platform



**Distributed by:** Auslift Equipment  
2/2-4 Souffi Place,  
Dandenong South, Vic.3175  
Telephone : 03 9702 7977  
Email: sales@auslift.com.au  
Website: www.auslift.com.au

**AUSLIFT**  
EQUIPMENT