

Specifications

MODELS	GS™-2668 RT		GS™-3268 RT	
MEASUREMENTS	Metric	US	Metric	US
Working height maximum*	9.92 m	32 ft	11.75 m	38 ft
A Platform height maximum	7.92 m	26 ft	9.75 m	32 ft
B Platform height - stowed	1.19 m	3 ft 10.75 in	1.31 m	4 ft 3.75 in
C Platform length - outside	2.51 m	8 ft 3 in	2.51 m	8 ft 3 in
extended	3.96 m	13 ft	3.96 m	13 ft
Slide-out platform extension deck	1.52 m	5 ft	1.52 m	5 ft
D Platform width - outside	1.71 m	5 ft 1 in	1.71 m	5 ft 1 in
Toeboard height	0.15 m	6 in	0.15 m	6 in
E Height - stowed**	2.32 m	7 ft 7.5 in	2.45 m	8 ft 5 in
rails lowered	1.70 m	5 ft 7 in	1.83 m	6 ft
F Length - stowed with outriggers	3.38 m	11 ft 3 in	3.38 m	11 ft 3 in
G Width	1.73 m	5 ft 8 in	1.73 m	5 ft 8 in
H Wheelbase	1.85 m	6 ft 1 in	1.85 m	6 ft 1 in
I Ground clearance - centre	0.20 m	8 in	0.20 m	8 in

PRODUCTIVITY

Maximum platform occupancy***				
- indoor	4	4	4	4
- outdoor	4	4	2	2
Lift capacity	567 kg	1,250 lbs	454 kg	1,000 lbs
Extension deck capacity	136 kg	300 lbs	136 kg	300 lbs
Drive speed - stowed	6.1 km/h	3.8 mph	6.1 km/h	3.8 mph
Drive speed - raised	0.8 km/h	0.5 mph	0.8 km/h	0.5 mph
Gradeability - stowed****	35%	35%	30%	30%
Maximum outrigger leveling:				
front to back	6.6°	6.6°	6.6°	6.6°
side to side	10.6°	10.6°	10.6°	10.6°
Turning radius - inside	1.52 m	5 ft	1.52 m	5 ft
Turning radius - outside	3.68 m	12 ft 1 in	3.68 m	12 ft 1 in
Raise/lower speed	30 / 35 sec	30 / 35 sec	40 / 37 sec	40 / 37 sec
Controls	proportional		proportional	
Drive	four wheel		four wheel	
Tyres - rough terrain	30 x 60 cm	12 x 23.5 in	30 x 60 cm	12 x 23.5 in

POWER

Power source	Kubota D-1105 Diesel 24.9 hp		Kubota D-1105 Diesel 24.9 hp	
Fuel tank capacity	56.8 L	15 gal	56.8 L	15 gal
Hydraulic system capacity	62.5 L	16.5 gal	62.5 L	16.5 gal

WEIGHT*****

with outriggers	3,415 kg	7,529 lbs	4,153 kg	9,156 lbs
-----------------	----------	-----------	----------	-----------

STANDARDS COMPLIANCE

ANSI A92.6, CSA B354.2, CE Compliance, AS 1418.10

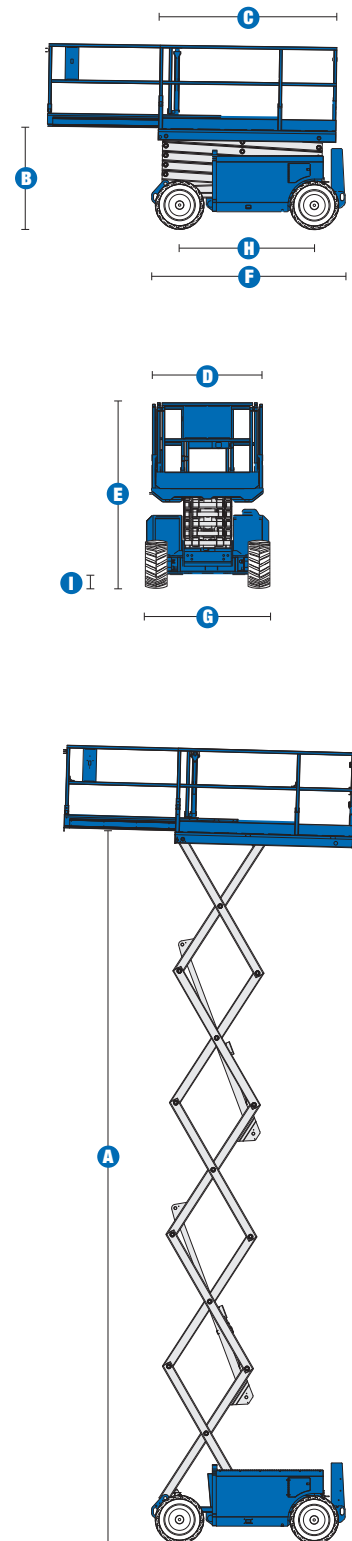

* The metric equivalent of working height adds 2 m to platform height. U.S. adds 6 ft to platform height.

** Based on RT tyres; deduct 2 in (5.8 cm) for turf and non-marking tyres.

*** CE/AUS markets: GS-3268 limited to 2 person platform occupancy when used outdoors.

**** Gradeability applies to driving on slopes. Gradeability may vary depending on the weight of options installed on machine. See operator's manual for details regarding slope ratings.

***** Weight varies depending on options and country standards.

Features

STANDARD FEATURES

MEASUREMENTS

GS™-2668RT

- 9.92 m (32 ft) working height
- Up to 567 kg (1,250 lb) lift capacity

GS™-3268RT

- 11.75 m (38 ft) working height
- Up to 454 kg (1,000 lb) lift capacity

PRODUCTIVITY

- 2.51 m x 1.55 m (8 ft 3 in x 5 ft 1 in) steel frame platform with replaceable diamond plate aluminum deck
- 1.52 m (5 ft) extension deck
- Automatic leveling hydraulic outriggers
- Folding guardrails
- Proportional lift and drive
- Full height swing gate
- 4WD
- Positive traction control
- Four-wheel braking
- Swing-out engine tray
- Foam-filled rough terrain tyres
- Tilt alarm
- Descent alarm
- Horn
- Hour meter
- Dual flashing beacons
- Motion alarm

POWER

- Kubota diesel 18.6 kW (24.9 hp)

OPTIONS & ACCESSORIES

PRODUCTIVITY

- Air line to platform
- Non-marking rough terrain tyres 30 x 60 cm (12 x 23.5 in)
- Platform work lights

POWER OPTIONS

- Cold weather package
- Arctic package
- 240 V power to platform



Auslift Equipment - Phone number - 03 9702 7977

AUSLIFT
EQUIPMENT

Effective Date: April, 2009. Product specifications and prices are subject to change without notice or obligation. The photographs and/or drawings in this document are for illustrative purposes only. Refer to the appropriate Operator's Manual for instructions on the proper use of this equipment. Failure to follow the appropriate Operator's Manual when using our equipment or to otherwise act irresponsibly may result in serious injury or death. The only warranty applicable to our equipment is the standard written warranty applicable to the particular product and sale and we make no other warranty, express or implied. Products and services listed may be trademarks, service marks or trade-names of Terex Corporation, Genie Industries, Inc. and/or their subsidiaries in the U.S.A. and many other countries and all rights are reserved. Terex is a Registered Trademark of Terex Corporation in the U.S.A. and many other countries. Genie is a Registered Trademark of Genie Industries, Inc. in the U.S.A. and many other countries. Genie is a Terex Company. © 2009 Terex Corporation.

GS-2668RT, GS-3268RT 090327 Ver1

www.auslift.com.au