

Product Specification

Type DHE-RJL10 Fixed Jib (Long)

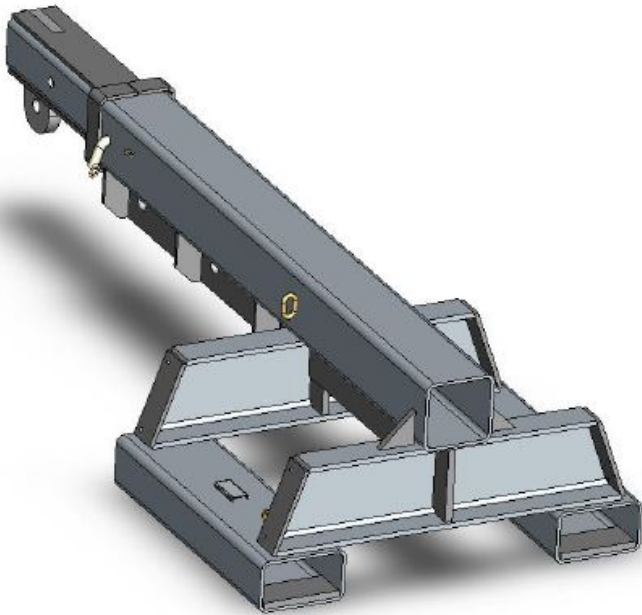

The type DHE-RJL10 Fixed Jib (Long) is designed as an affordable general purpose Jib with a 3.56 metre reach when fully extended. This Jib has been designed with wide pockets suitable for Forklifts with special hydraulic Tine Positioners. This slip-on Forklift attachment is held to the Forklift by a safety chain. The Jibs overall length when closed is 2.19 metres. Supplied with safety swivel Hook and Shackle.

SPECIFICATIONS:

- Safe Working Load (SWL) 10,000kg Max.
- Unit Weight 515kg
- Load Centre 920mm
- Pocket Size 230 x 110
- Pocket Centres 875 mm
- Horizontal C of G 1200mm
- Vertical C of G 100mm
- Zinc Finish

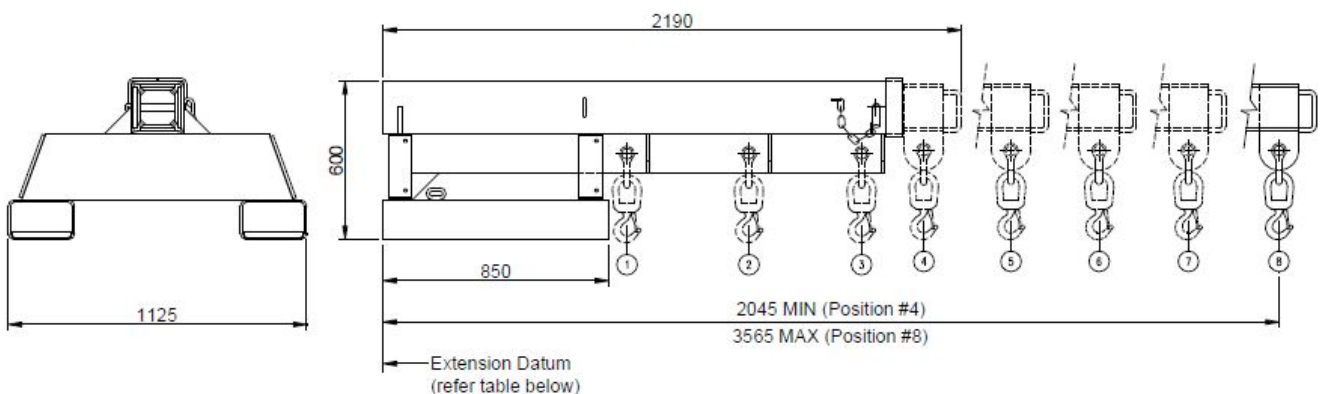

SAFE WORKING LOADS (SWL) PER POSITION								
POSITION	1	2	3	4	5	6	7	8
EXTENSION (mm)	920	1380	1805	2045	2425	2805	3185	3565
SWL (kg)	10,000	8550	7600	6600	5000	2600	1520	960