

Product Specification

FORKLIFT JIB CRANE

DHE.1100

The DHE-1100 Forklift Jib Crane increases the versatility of a Forklift in materials handling and often outperforms overhead cranes. It features a two metre reach and three fixed lifting points. Powder coated in safety yellow. Comes with safety hook and shackle.

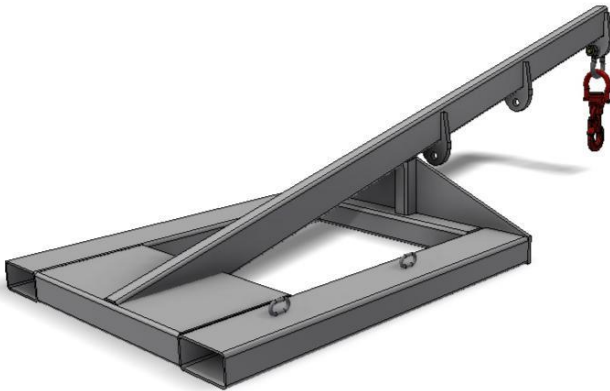

SPECIFICATIONS:

- Safe Working Load (SWL 1100kg Max)
- Unit weight 85kg
- Horizontal Centre of Gravity 725mm
- Vertical Centre of Gravity 120mm
- Pocket size 135 x 85mm
- Pocket centres 730mm

SAFE WORKING LOADS (SWL) PER POSITION			
POSITION	1	2	3
EXTENSION	1100	1510	2000
SWL (kg)	1100	960	690

