

Product Specification

FORKLIFT SLIPPERS CLASS 4-7



Forklift slippers are designed and manufactured to temporarily extend existing fork tynes and shouldn't be used as a permanent attachment. In accordance with AS2359.15 fork slippers used for general usage should be no longer than 167% of the supporting tyne's length. If the slippers are longer than 167%, then the usage of those slippers shall be restricted to their specified application. When using Fork Slipper Tyne Extensions, caution must be exercised to ensure that they are used only for load stabilizing purposes and that the load is uniform and fully supported by the appropriate fork tyne. Zinc plated finish. Supplied with heel lock pins.

Please note: Class 4-7 slippers are custom made to order. Please contact for pricing and to discuss your requirements.

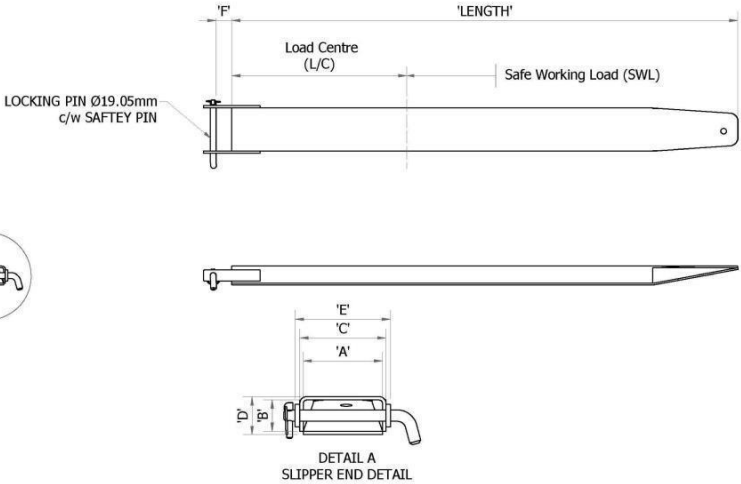

TYPE	FORK CAPACITY (KG)	DIMENSIONS (MM)						WEIGHT PER PAIR (KG)	HORIZONTAL CENTRE OF GRAVITY (MM)	SAFE WORKING LOAD (SWL) AT LOAD CENTRE (LC)	
		LENGTH	POCKET SIZE (A X B)	C	D	E	F				
DHE.CL4-1783	5000-8000	1783	174 X 72	200	81	220	90	115	TBC	8000KG AT 600MM LC	
DHE.CL4-2100	5000-8000	2100	174 X 72	200	81	220	90	136	TBC	8000KG AT 600MM LC	
DHE.CL4-2400	5000-8000	2400	174 X 72	200	81	220	90	156	TBC	8000KG AT 600MM LC	
DHE.CL4-3000	5000-8000	3000	174 X 72	200	81	220	90	195	TBC	8000KG AT 600MM LC	
DHE.CL5-1783	8001-10999	1783	MANUFACTURED TO SUIT								8000KG AT 600MM LC
DHE.CL5-2100	8001-10999	2100	MANUFACTURED TO SUIT								8000KG AT 600MM LC
DHE.CL5-2400	8001-10999	2400	MANUFACTURED TO SUIT								8000KG AT 600MM LC
DHE.CL5-3000	8001-10999	3000	MANUFACTURED TO SUIT								8000KG AT 600MM LC
DHE.CL6-2100	11000-15000	2100	MANUFACTURED TO SUIT								12000KG AT 600MM LC
DHE.CL6-2400	11000-15000	2400	MANUFACTURED TO SUIT								12000KG AT 600MM LC
DHE.CL6-3000	11000-15000	3000	MANUFACTURED TO SUIT								12000KG AT 600MM LC
DHE.CL7-2400	15001+	2400	MANUFACTURED TO SUIT								16000KG AT 600MM LC
DHE.CL7-3000	15001+	3000	MANUFACTURED TO SUIT								16000KG AT 600MM LC
DHE.CL7-3500	15001+	3500	MANUFACTURED TO SUIT								16000KG AT 600MM LC