

## Product Specification

### FORKLIFT SLIPPERS CLASS 3

Forklift slippers are designed and manufactured to temporarily extend existing fork tyne and shouldn't be used as a permanent attachment. In accordance with AS2359.15 fork slippers used for general usage should be no longer than 167% of the supporting tyne's length. If the slippers are longer than 167%, then the usage of those slippers shall be restricted to their specified application. When using Fork Slipper Tyne Extensions, caution must be exercised to ensure that they are used only for load stabilizing purposes and that the load is uniform and fully supported by the appropriate fork tyne. Zinc plated finish. Supplied with heel lock pins.

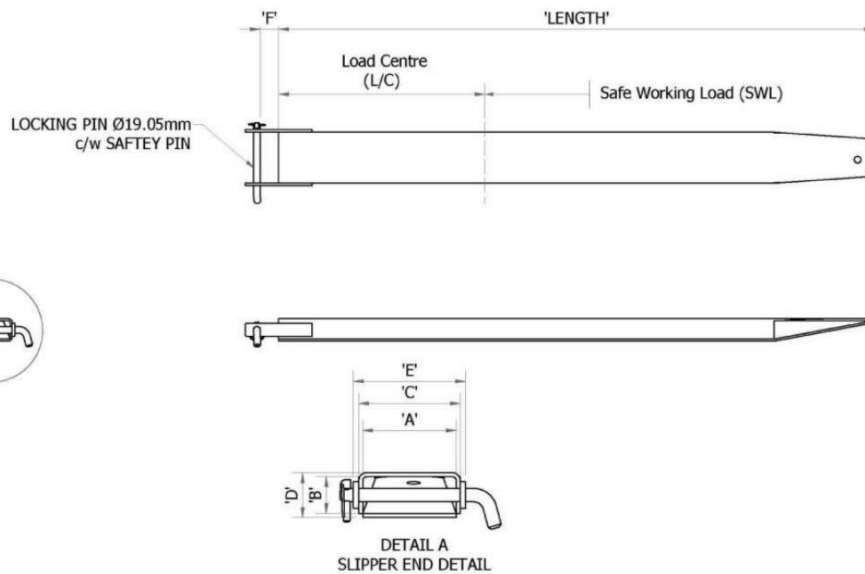

TYPE	FORK CAPACITY (KG)	DIMENSIONS (MM)						WEIGHT PER PAIR (KG)	HORIZONTAL CENTRE OF GRAVITY (MM)	SAFE WORKING LOAD (SWL) AT LOAD CENTRE (LC)
		LENGTH	POCKET SIZE (A X B)	C	D	E	F			
DHE.CL3-1600	2501-4999	1600	160 X 70	180	80	200	70	90	740	5000KG AT 600MM LC
DHE.CL3-1783	2501-4999	1783	160 X 70	180	80	200	70	101	830	5000KG AT 600MM LC
DHE.CL3-2100	2501-4999	2100	160 X 70	180	80	200	70	120	982	5000KG AT 600MM LC
DHE.CL3-2400	2501-4999	2400	160 X 70	180	80	200	70	135	1130	5000KG AT 600MM LC
DHE.CL3-3000	2501-4999	3000	160 X 70	180	80	200	70	168	1440	5000KG AT 600MM LC