

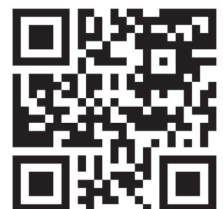

AC ELECTRIC WINCHES





OZWINCHES ARE LIGHTWEIGHT YET STRONG, INCREDIBLY DURABLE, SAFE AND FANTASTIC VALUE FOR MONEY.

They are all of the planetary design, rugged in construction and engineered to comply to Australian Standards. Built with a precision planetary gear train, they feature quality roller bearings throughout, a high starting torque motor designed specifically for winch hauling and hoisting applications and a fail safe electromagnetic disc brake to provide safe, easy load control.

All OzWinches (240V as well as 415V) incorporate a low voltage 24V pendant control with 10m lead and an emergency stop button.

The pendant also has a quick disconnect system so when your winch is not in use, no one else can tamper with it.

Uniquely, all OzWinches have the option of being configured with a wireless remote control system or hand held pendant control as standard. Two system control options for your convenience.



AFTER SALES SERVICE AND REPAIRS

As Australia's leading winch supplier we understand that in addition to getting the best equipment for your requirements, you also need to keep it operational which is why we back our superior equipment with responsive service and repair capabilities. All repairs and maintenance are performed by accredited technicians.

An extensive selection of spare parts for most models is available to minimise any delays to equipment repairs.

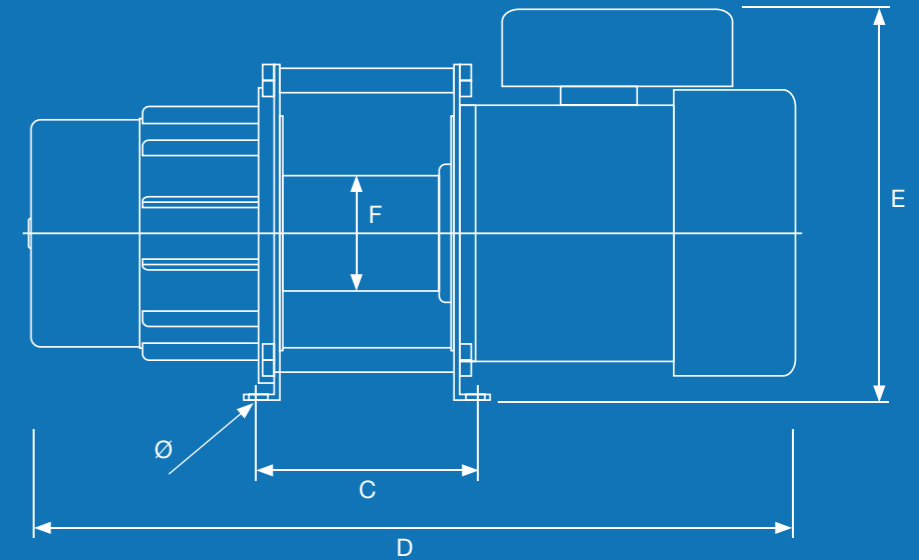
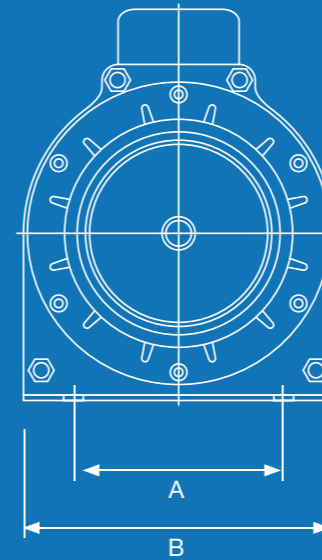

STANDARD FEATURES:

- AC motor for maximum torque, designed specifically for winch applications
- 240V single phase model is pre-wired with 3-pin plug
- Wire rope with safety hook
- Low Voltage hand control with 10m lead (removable) on all models
- Thermal overload protection
- Optional wireless remote control
- Optional synthetic rope

APPLICATIONS:

- Hauling on domestic boat ramps
- Lifting in small workshops
- Home handyman
- Positioning caravans & trailers in confined areas
- Lifting sullage pumps
- Ideal for building sites
- Industrial bin retrieval
- Agricultural environments

JV SERIES		Lifting Capacity	Avg Speed (m/min)	Rope	Voltage	Motor (Kw)	Body Dimensions (mm)						Weight (kg)
Model							A	B	C	D	E	F	Ø
JV-1020-13D03	200kg	11	6mmX30m	1Ph 240V	0.5	142	210	142	522	285	76	10	31.2
JV-1025-13D03	250kg	11	6mmX30m	1Ph 240V	0.55	142	210	142	527	285	76	10	32
JV-1030-13D03	300kg	11	6mmX30m	1Ph 240V	0.75	142	210	142	527	285	76	10	35.5

JC SERIES		Lifting Capacity	Avg Speed (m/min)	Rope	Voltage	Motor (Kw)	Body Dimensions (mm)						Weight (kg)
Model							A	B	C	D	E	F	Ø
JC-1025-17D12	250kg	17	6mmX120m	1Ph 240V	1.6	160	250	250	694	290	105	17	62.5
JC-1030-16D05	300kg	13	6mmX50m	1Ph 240V	1.1	160	220	186	605	300	76	13	38.6
JC-1050-16F03	500kg	13	8mmX30m	1Ph 240V	1.6	160	220	186	613	305	78	13	48.5
JC-1050-21F05	500kg	17	8mmX50m	1Ph 240V	1.8	160	250	206	653	315	105	17	58.7

PU SERIES		Lifting Capacity	Avg Speed (m/min)	Rope	Voltage	Motor (Kw)	Body Dimensions (mm)						Weight (kg)
Model							A	B	C	D	E	F	Ø
PU-1070-09G07	700kg	7.5	9mmX70m	1Ph 240V	1.3	202	292	265	783	340	101	17	86.5
PU-1120-10I05	1200kg	8	12mmX50m	1Ph 240V	2	260	390	243	785	415	168	22	130.7
PU-1200-07J07	2000kg	6	14mmX70m	1Ph 240V	2.5	260	390	373	915	415	168	22	166.0
PU-3200-07J07	2000kg	6	14mmX70m	3Ph 415V	3	260	390	373	915	415	168	22	166.0

HES WINCHES AUSTRALIA:
QUALITY WINCH SOLUTIONS,
PROFESSIONAL ADVICE AND
OUTSTANDING SERVICE.



CALL US: 1300 946 242
EMAIL: sales@heswinches.com.au
WEB: www.heswinches.com.au