



MX1100G

VHF MARINE RADIO

INSTRUCTION MANUAL

- Ingress protected to IPX7*
- Independent Class B DSC Dedicated Receiver
- Speaker Vibration Draining Function
- Built-in GPS Receiving Module

* The MX1100G meets IPX7 standard.
This is capable of withstanding water immersion of
up to 1m for 30 minutes.



Need Help?

If you need assistance setting up or using your Oricom product now or in the future, call Oricom Support Australia on:
(02) 4574 8888
www.oricom.com.au

Mon-Fri 8am – 6pm AEST

New Zealand
0800 67 42 66
Mon-Fri 10am – 8pm NZST

Thank you for purchasing this Oricom VHF Marine Radio.

Please ensure you read this user guide carefully before using the MX1100G Radio to ensure you familiarise yourself with the functions and operation.

PLEASE RETAIN THE USER GUIDE FOR FUTURE REFERENCE.

Compliance

The MX1100G complies with the Australian Communications and Media Authority Radiocommunications VHF Radio Telephone Equipment - Maritime Mobile Service Standard 2018 when assessed and tested in accordance with ETSI EN 301 025 V2.2.1 (2017-03).

OPERATING RULES

Priorities

Read all rules and regulations relating to priorities and keep an up-to-date copy. Safety and distress calls take priority over all other calls. You must always monitor Channel 16 when you are not operating on another channel. False or fraudulent distress calls are prohibited by law.

Privacy

Information overheard but not intended for you cannot be used in any way by law. Offensive or disrespectful language is prohibited.

RADIO LICENCES

Ship Station License

VHF Marine Radios in Australia are covered by a Class License. For more information, visit: <https://www.acma.gov.au/Citizen/TV-Radio/Radio/Marine-and-Amateur-Radio/marine-vhf-radio-1>

Operators License

For information on using this product in Australia, visit the ACMA website below: <https://www.acma.gov.au/theacma/marine-vhf-radio>

RANGE

The range of VHF transmissions depends on antenna height, transmitter power and the terrain over which the signals pass.

DIGITAL SELECTIVE CALLING (DSC)

The Digital Selective Calling (DSC) feature on your MX1100G Marine VHF radio uses an arranged digital data message, instead of voice, in order to transmit urgent or important information to another radio.

DSC is designed to alert all radios within a predetermined range to a distress message, even if the vessel's listening watch is not being maintained, as this increases the chance of the signal being heard.

Thank you for purchasing this VHF DSC marine radio. Please read all instructions carefully and completely before using the radio.

The radio is based on the technical characteristics of CCIR 493-4 and the operational characteristics of CCIR 541-3 of the International Radio Consultative Committee, and the resolutions of the International Telecommunication Union ITU-R Recommendation A.803(19), complying with national regulations and combined with practical use, a versatile Class B VHF DSC marine radio, it has a dedicated DSC receiving channel.

This radio adopts advanced waterproof technology and has excellent waterproof performance.

PLEASE NOTE: this radio requires a MMSI number to use the DSC functions. It will prompt you to enter the number each time the radio is turned on until you enter your MMSI number. Bypass entry of the MMSI by pressing the BACK button please see page 14 for MMSI code programming.

WARNING

- When transmitting, keep your body or head more than 20cm from the antenna.
- DO NOT transmit near electrical blasting equipment, or in explosive atmospheres.
- DO NOT allow children to operate a radio transmitter unsupervised.

CAUTION

- Only use the DISTRESS call when your ship, or a person on the vessel is in an emergency.
- Avoid installation in direct sunlight or high heat, humidity and dust.
- The working voltage for the radio is 13.8V. If the power source is 24V, ensure a power converter (24V convert to 13.8V) is used, otherwise the radio will not work.
- Never directly connect to 230V AC, as this will damage the radio. If an abnormal odor or smoke is detected from the radio, turn off the power immediately.
- Do not transmit before connecting the antenna, as this will damage the radio.
- During extended periods of use, it is normal for the radio housing to become warm.

CONTENTS

PREPARATION

Supplied Accessories	1
Radio Mounting	1
Antenna Connection	2
Installation of Connecting Cables	2
Dimensions	3

PANEL DESCRIPTION

Front Panel	4
Softkeys	5
Microphone	6
Function Display	6

BASIC OPERATION

Power ON/OFF	8
Transmitting and Receiving	8
Channel Group Selection	9
Channel Selection	9
Call Channel Programming	10
Channel Name	10
Display Backlight	10
Display Contrast	11
Vibration Water Draining Function	11
Microphone Lock Function	11

SCAN OPERATION

Scan Types	12
Setting TAG Channels	12
Starting a Scan	12

DUALWATCH / TRI-WATCH

Description	13
Operation	13

DSC OPERATION

MMSI Code Programming	14
ATIS ID Programming	14
DSC Address ID	15
Distress Call	18
Individual Call	21
Group Call	24
All Ships Call	25
Position Request Call / Polling Request Call	26
Test Call	29
DSC Log	32
Multiple-task Mode	32

MENU SCREEN OPERATION

Menu Screen Operation	35
Menu Screen Items	35
Radio Settings	36
Configuration	37

VHF MARINE RADIO CHANNEL LIST (Default International)

SPECIFICATIONS

TROUBLESHOOTING

PREPARATION

■ Supplied Accessories

The following accessories are supplied:

ITEM	QTY
DC Power Cable	1
Spare Fuse	1
Mounting Bracket	1
Mounting Screws Package	1
Instruction Manual	1
GPS Antenna	1

■ Radio Mounting

◆ Using the Supplied Mounting Bracket

The universal mounting bracket supplied with your radio allows overhead or dashboard mounting.

1. Fix the mounting bracket to overhead or dashboard with the supplied screws and mount the radio to the mounting bracket with the knob bolts.
2. Adjust the radio so that the face of the radio is at 90° to your line of sight when operating it and tighten the knob bolts so that the radio is securely mounted.

NOTE: You may use a spongy cushion between the trans-ceiver and mounting bracket to reduce the impact of vibration.

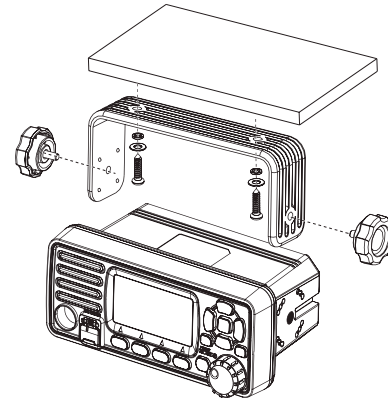

■ Antenna Connection

Please connect an antenna before transmitting. Make sure you are using a good quality VHF antenna, Connect the antenna cable to the rear antenna socket using a PL259 coaxial connector with natural impedance 50Ω.

NOTE: Do not transmit without an antenna connected as this will damage the radio.

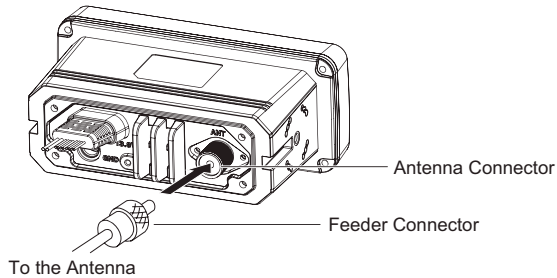

■ Installation of Connecting Cables

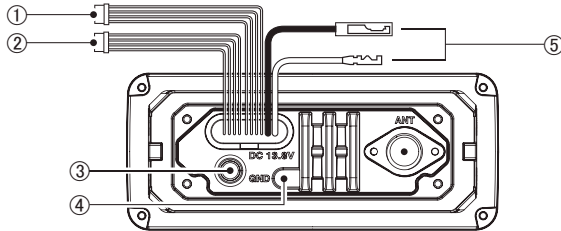

When connecting the external speaker, GPS, DC power supply, computer and navigation device by the rear panel cable end, cover the connectors and cables with rubber vulcanizing tape as below, to prevent water seeping into the radio.

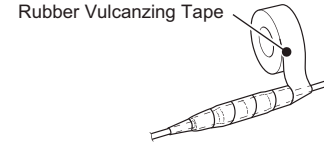

1. External Speaker and Programming Data Leads

- Connect an external speaker to Blue and Black Lead. Blue→Positive Electrode (+), Black→Negative Electrode (-).
- Connect programming cable to Orange and Grey Lead.

2. NMEA/Out Leads

Through the rear panel lead, this radio can connect output GPS signals to other devices.

- **Output Connection:** Connect the output to the navigation device input line (port) that supports NMEA0183 for receiving location data from other ships, connect as follows: Brown→Sending Data, Data Output (-); White→Sending Data, Data Output (+).
- **Input Connection:** Connect to the NMEA output line (port) 3 of the GPS receiver for location data, connect as follows: Green→Receiving Data, GPS Input (-); Yellow→Receiving Data, GPS Input (+).

NOTE: The output signal of this radio complies with NMEA0183 version 2.0 or above, compatible with DSC, DSE navigation equipment, statement format RMC, GSA, GSV.

3. External GPS Antenna

Connect to an external GPS antenna.

NOTE: Make sure that the GPS antenna is installed in an open, unobstructed position so that the satellite signal can be received well. When installing the GPS antenna, use the supplied double-sided tape to fix it.

4. Ground Terminal

Connect this terminal to a vessel ground to prevent electrical shocks and interference from other equipment. Use a PH M3×6 mm screw (not supplied).

5. DC Power Connector

Red - Positive(+), Black - Negative(-).The output voltage of the connected DC power supply must be 13.8V, do not connect the radio to a 24V storage power supply. If the current supplied to the radio is insufficient, the display may darken during transmission or the transmitting output power may drop significantly.

NOTE: Connect the DC power cable to a 13.8V DC power supply. Note: make sure the correct polarity is observed, connect red cable to positive (+) and black cable to negative (-) terminals.

◆ Fuse Replacement

One fuse is installed in the supplied DC power cable. If a fuse blows or the radio stops functioning, track down the source of the problem first, then replace the damaged fuse with a new, rated one.

NOTE: Please power off radio before replacing the fuse, the required fuse is DC15A/32V.

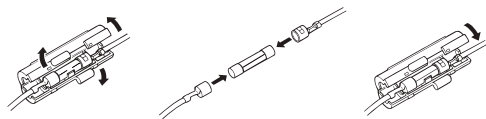

■ Dimensions

Unit: mm

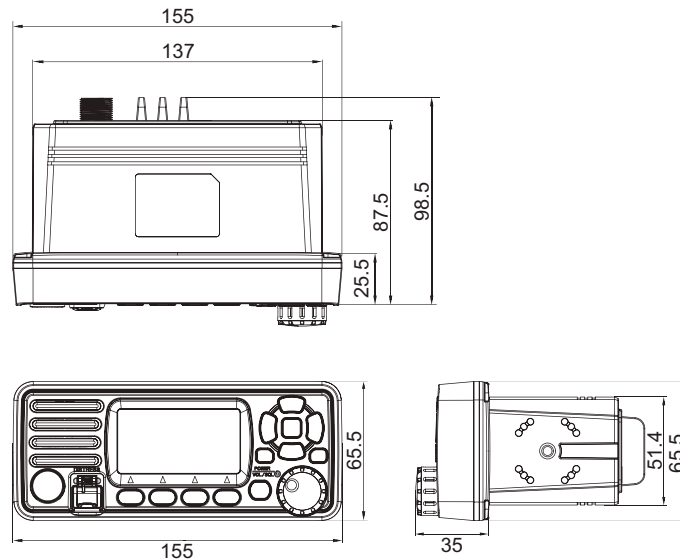

PANEL DESCRIPTION

Front Panel

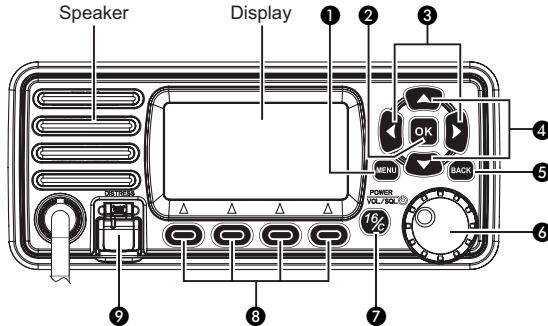

1 Menu Key [MENU]

- Press this key to enter or exit the menu operation display interface.

2 Enter Key [OK]

- Press this key to set the entered data, selected items, etc.

3 Left/Right Keys [◀]/[▶]

- Press to scroll through the softkey functions.
- Press to select a character or number in input mode.

4 Up/Down Keys [▲]/[▼]

- Press to select work channel, menu items, menu settings, etc.
- Press to select a character or number in the entry in input mode.

5 Clear Key [BACK]

- Press to cancel the settings, or exit the DSC menu.

6 Power/Volume/Squelch Knob [PWR/VOL/SQL]

- Press and hold for one second to power ON/OFF the radio.
- Rotate or press to enter the volume setting display interface, then rotate to adjust the volume.
- Press twice to enter the squelch level setting display interface, then rotate to adjust the squelch.
- In the menu interface, rotate to select menu items.
- In input mode, press to select a character or number, and rotate to move the cursor.

7 Channel 16 / Call Channel Key [16/C]

- Press to select Channel 16.
- Press and hold for one second to select Call Channel (Default Channel 9).
- “**[CALL]**” appears when the Call channel is selected.



8 Softkeys [◻]

- Press [◀] or [▶] to scroll through the key functions at the bottom of the display, then press the 4 softkeys [◻] to select the key function.
- The definition of the softkeys is described in the following description.

9 Distress Key [DISTRESS]

- Open the cover, press and hold this key for 3 seconds to transmit a Distress call.

Softkeys

Frequently used functions are assigned to the softkeys [] for easy access. The functions' icons are displayed above the softkeys [], as shown below.

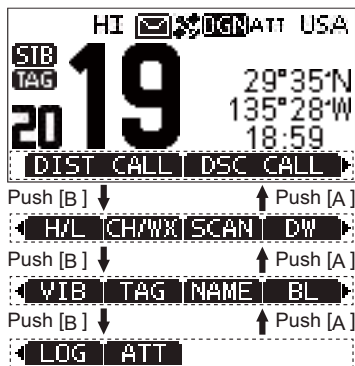

NOTE: The displayed icons or their order may differ depending on software version. When the MMSI code is not set, the softkeys for DSC function are not displayed.

Using the Softkeys

Press [◀] or [▶] to scroll through the selectable functions that are assigned to the softkeys []. Press the softkeys [] under the functions's icon to select the function.

Softkey Functions

The softkey functions that can be implemented are as follows:

1. Distress Call []

Press to display the “DISTRESS” screen, to select the Nature of distress, then to make a call.

- “  ” is displayed.

NOTE: NEVER make a distress call if your ship or a person is not in an emergency. A distress call should be made only when immediate help is needed.

2. Other DSC []

Press to select DSC CALL, including Individual Call, Group Call, All Ships Call, Test Call.

- “  ” is displayed.

3. Task List []

Press to display Task List.

4. Scan []

Press to start or stop Normal Scan or Priority Scan.

5. Dualwatch/Tri-watch []

Press to start or stop Dualwatch/Tri-watch.

6. High/Low Power []

Press to set output power to high or low.

- Some channels are set to low power only.

7. Channel/Weather Channel []

Press to select regular channels or Weather Channel.

- The Weather Channel is for USA and Australian versions only. “  ” is displayed for other versions.
- While the Call channel or Channel 16 is displayed, press this key to return to regular channel mode.

8. Attenuation []

Press to turn the Attenuator ON or OFF.

9. Vibration Water Draining [**VIB**]

Press and hold this key to turn ON Vibration Water Draining function to clear water from the speaker grill.

10. Favourite Channel [**TAG**]

Press to set or release the displayed channel as a Favourite Channel.

- Press to set current untagged channel as TAG channel;
- Press again to clear the TAG channel.

11. Channel Name [**NAME**]

Press to edit the name of the displayed channel.

12. Backlight [**BL**]

Press to enter display and keypad backlight brightness adjustment mode, press [◀]/[▶], [▲]/[▼] keys or rotate [DAIL] knob to adjust display and keypad backlight brightness.

- 8 levels of backlight brightness: 1~7, OFF.

13. Log [**LOG**]

Press to display received call log or distress message log.

Microphone

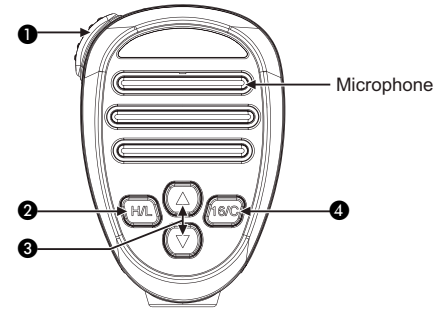

1 PTT Switch [PTT]

- Press and hold to transmit; Release to receive.

2 Transmit Power Key [H/L]

- Press to select high or low output power. Some channels are set to low power only.
- While pressing and holding [H/L], power ON to toggle the microphone lock function ON or OFF.

3 Channel [▲][▼] Keys

- Press to select operating channel, Set mode setting etc.
- When the favourite channel function is activated, press [▲]/[▼] keys to select the favourite channels in the selected channel group in sequence.

4 Channel 16 / Call Channel Key [16/C]

- Press to select Channel 16.
- Press and hold for one second to select Call Channel (Default Channel 9). "CALL" appears when the Call channel is selected.

■ Function Display

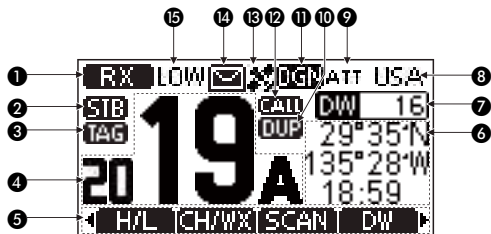

No.	Name	Descriptions
1	Signal Status Indicator	<ul style="list-style-type: none"> • “RX” displayed while receiving. • “TX” displayed while transmitting.
2	Status Indicator	<ul style="list-style-type: none"> • “STB” displayed when in the standby mode. • “R/T” displayed when the channel is changed while receiving or transmitting a signal.
3	Favourite Channel Icon	<ul style="list-style-type: none"> • “TAG” displayed when the Favourite channel is selected.
4	Operating Channel Number	<ul style="list-style-type: none"> • Displays the selected operating channel number, can display 4 digits channel number. • “A” or “B” is displayed when a simplex channel is selected.
5	Softkeys Function Display	<ul style="list-style-type: none"> • The functions of softkeys are displayed.
6	Position/Time Readouts	<ul style="list-style-type: none"> • Readouts the current position and time when valid GPS data is received or when manually input. • “NO POS NO TIME” is displayed if no GPS data has been received, and then a warning message is displayed for 2 minutes after turning ON the radio. • “??” blinks if no GPS data is received for 30 seconds after receiving valid GPS data, and then “??” and a warning message are displayed after 10 minutes. • A warning message is displayed if no GPS data is received for 4 hours after receiving valid GPS data. • A manually input GPS data is valid for 23.5 hours, and then a warning message is displayed.

7	Scan Indicator	<ul style="list-style-type: none"> • “SCAN 16” is displayed while Priority Scan, “SCAN” is displayed while Normal Scan. • “DW 16” is displayed while Dualwatch, “TW 16” is displayed while Tri-watch.
8	Channel Group Indicator	<ul style="list-style-type: none"> • “USA” is displayed when USA channel group is selected. • “INT” is displayed when International channel group is selected. • “CAN” is displayed when Canada channel group is selected. • “WX” is displayed when Weather channel group is selected. • When the WX-Alert is set to ON, “WX☁” is displayed instead of “WX”.
9	Attenuator Icon	<ul style="list-style-type: none"> • “ATT” is displayed when RF attenuation is ON.
10	Duplex Channel Indicator	<ul style="list-style-type: none"> • “DUP” is displayed when a Duplex channel is selected.
11	GPS Status Icon	<ul style="list-style-type: none"> • GP: GPS; GN: GPS+GLONASS; • DGP: SBAS+GPS; • DGN: SBAS+GPS+GLONASS
12	Call Channel Indicator	<ul style="list-style-type: none"> • “CALL” is displayed when a Call channel is selected.
13	GPS Positioning Icon	<ul style="list-style-type: none"> • Displayed when valid GPS position data (Including GPS and GLONASS) is received. • Blinks when received GPS position data is invalid.
14	Message Icon	<ul style="list-style-type: none"> • “✉” is blinked when there is an unread DSC message, “✉” disappears when the message has been read.
15	Output Power Icon	<ul style="list-style-type: none"> • “HI” is displayed when high power is selected. • “LOW” is displayed when low power is selected.

BASIC OPERATION

■ Power ON/OFF

1. Press and hold [PWR] knob for 1 second to power ON.
2. Press and hold [PWR] knob for 1 second again to power OFF.

■ Transmitting and Receiving

◆ Transmitting

1. Press [H/L] key on the microphone to select the output power if necessary.
 - “LOW” appears when low power is selected.
 - Choose low power for short range communication, choose high power for longer distance communication.
 - Some channels are low power only.
2. Press and hold [PTT] key to transmit, then speak into the microphone.
 - “TX” appears.
 - CH70 is for DSC transmitting only.
3. Release [PTT] to receive.

NOTE: Do not transmit without an Antenna as this will damage the radio. If the TOT function is enabled by the PC programming software, the transmission time-limited protection function prohibits continuous transmission for a long time.

◆ Receiving

Volume Adjustment:

1. Rotate [VOL] knob to adjust the volume, volume adjustment interface is displayed.

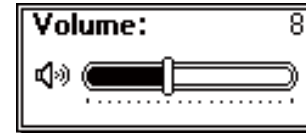

2. If no key is pressed within 5 seconds, the interface will automatically exit.

Squelch Level Adjustment:

1. Press [SQL] knob twice, squelch level adjustment interface is displayed.
2. Rotate [SQL] knob to adjust the squelch level.

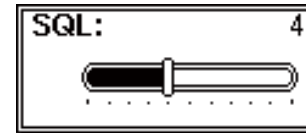

3. If no key is pressed within 5 seconds, the interface will automatically exit.

■ Channel Group Selection

Channel Groups are pre-programmed.

1. Press **[MENU]** key, the menu interface is displayed.
2. Press **[▲]/[▼]** or rotate **[DIAL]** knob to select "Radio Settings", then press **[OK]**, the "RADIO SETTINGS" screen is displayed.
3. Press **[▲]/[▼]** or rotate **[DIAL]** knob to select "Channel Group", then press **[OK]**, the "CHANNEL GROUP" screen is displayed.
4. Press **[▲]/[▼]** or rotate **[DIAL]** knob to select a Channel Group, then press **[OK]**, the selected Channel Group Icon is displayed on the operating screen. Press **[EXIT]** to exit the menu screen.

■ Channel Selection

◆ Regular Channel

Press **[▲]/[▼]** to select regular channel.

◆ Channel 16

Channel 16 is the distress and safety channel. It is used for establishing initial contact with a station and for emergency communications. Channel 16 is monitored during both Dualwatch and Tri-watch.

1. Press **[16/C]** to select Channel 16.
2. Press **[◀]/[▶]** to display **[CH/WX]**, then press the softkey below **[CH/WX]**, to return to the previously selected channel.

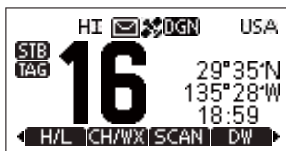

◆ Call Channel

Each regular channel group has a separate leisure-use Call channel (Default Channel 9). The Call channel is monitored during Tri-watch.

1. Press and hold **[16/C]** for 1 second to select the Call channel of the selected channel group. "**CALL**" and Call channel number appear.
2. Press **[◀]/[▶]** to display **[CH/WX]**, then press the softkey below **[CH/WX]**, to return to the previously selected channel. Press **[▲]** or **[▼]** to select channel.



◆ Weather Channels

The radio has 10 weather channels.

The radio can automatically detect a weather alert tone on the selected weather channel while receiving on a regular channel or while scanning.

Selecting a Weather Channel

1. Press softkey **[CH/WX]** to select between weather channel and regular channel.
 - "WX" appears when a weather channel is selected.
 - When the WX-Alert is set to ON, "WX" with a weather icon is displayed instead of "WX".
2. Press **[▲]/[▼]** to select a Weather channel.



Setting the Weather Alert

1. Press **[MENU]** key, the menu interface is displayed.
2. Press **[▲]/[▼]** or rotate **[DIAL]** knob to select "Radio Settings", then press **[OK]**, the "RADIO SETTINGS" screen is displayed.
3. Press **[▲]/[▼]** or rotate **[DIAL]** knob to select "WX Alert", then press **[OK]**, the "WX ALERT" screen is displayed.
4. Select "On With Scan" or "On", "WX" is displayed on screen.

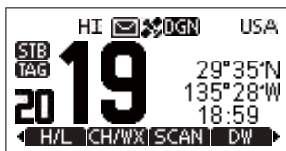

Call Channel Programming

Call channel is used to select Channel 9 (default), however, you can program the Call channel with your most offer-used channel in each channel group for quick recall.

1. Press **[MENU]** key, the menu interface is displayed.
2. Press **[▲]/[▼]** or rotate **[DIAL]** knob to select "Radio Settings", then press **[OK]**, the "RADIO SETTINGS" screen is displayed.
3. Press **[▲]/[▼]** or rotate **[DIAL]** knob to select "Call Channel", then press **[OK]**, the "CALL CHANNEL" screen is displayed.
4. Press **[▲]/[▼]** or rotate **[DIAL]** knob to select the desired Call channel.
5. Press **[OK]** to confirm, the selected channel is set as Call channel.
6. Press softkey **[EXIT]** to cancel and exit.



Channel Name

Each channel can be assigned a name of up to 10 characters. Characters available for input: 26 uppercase letters, number 0~9, symbol (! " # \$ % & '()* +,-./ :[]^ _;<=> ?), SPACE.

1. Press **[▲]/[▼]** to select the channel you want to edit.
 - Before setting, you should exit Dualwatch, Tri-watch or scan.
2. Press **[◀]/[▶]** to display **[NAME]**.
3. Press softkey **[NAME]**, the "CHAN NAME" screen is displayed.



4. Select **[!\$?]** to input symbols, and select **[123]** to input numbers and letters.
5. Press **[▲]/[▼]** or **[◀]/[▶]** to select characters or space.
6. Press **[OK]** to input the selected character.
7. Select "←" or "→", or rotate **[DIAL]** to move the cursor.
8. Repeat steps 4~7 to input all the characters.
9. Press softkey **[EXIT]** to cancel editing.
10. Press softkey **[FIN]** to save the edited name and return to the operating screen.

Display Backlight

Backlight brightness of the LCD display and keypads can be set by this function, totally 7 levels of brightness and OFF optional.

1. Press **[MENU]** key, the menu interface is displayed.
2. Press **[▲]/[▼]** or rotate **[DIAL]** knob to select "Configuration", then press **[OK]**, the "CONFIGURATION" screen is displayed.
3. Press **[▲]/[▼]** or rotate **[DIAL]** knob to select "Backlight", then press **[OK]**, the "BACKLIGHT" screen is displayed.

4. Press [▲]/[▼] or rotate [DIAL] knob to adjust the backlight brightness.
5. Press [OK] to confirm.
 - Press softkey [EXIT] to return to main interface.

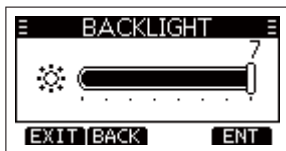

■ Display Contrast

LCD display contrast can be set by this function, Level 1 to 8.

1. Press [MENU] key, the menu interface is displayed.
2. Press [▲]/[▼] or rotate [DIAL] knob to select “Configuration”, then press [OK], the “CONFIGURATION” screen is displayed.
3. Press [▲]/[▼] or rotate [DIAL] knob to select “Display Contrast”, then press [OK], the “CONTRAST” screen is displayed.
4. Press [▲]/[▼] or rotate [DIAL] knob to adjust the display contrast.
5. Press [OK] to confirm.
 - Press softkey [EXIT] to return to main interface.

■ Vibration Water Draining Function

Vibration helps drain water away from the speaker housing (water that might otherwise muffle the sound coming from the speaker). The radio makes a vibrating noise when this function is being used.

NOTE: Do not use the vibration water draining function when connecting an external speaker.

1. Press [◀]/[▶] to display [VIB].
 - “VIB WATER” interface is displayed.

2. Press and hold softkey [VIB], the radio emits a low sound for draining.
3. Release softkey [VIB] to turn vibration water draining function OFF.

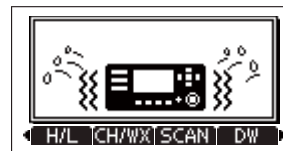

■ Microphone Lock Function

The microphone lock function electrically locks all keys except for [PTT] on the supplied microphone. This prevents accidental channel changes and function access.

1. Press and hold [DIAL] knob for one second to power OFF.
2. While pressing and holding [H/L] on the microphone, power ON to toggle the microphone lock function ON or OFF.

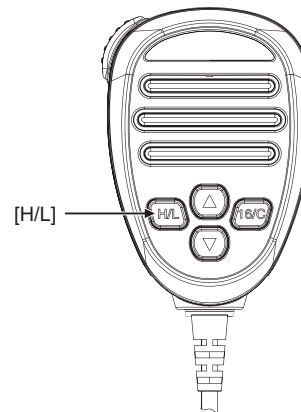

SCAN OPERATION

■ Scan Types

This radio has normal scan and priority scan, this can be set in the menu item under "Radio Settings".

When the weather alert function is turned ON, the previously selected (last used) weather channel is also scanned.

Set the TAG channels (scanned channels) before scanning.

Clear the TAG channels which you would like to scanning.

Normal Scan: Normal scan searches through all TAG channels in sequence. Channel 16 is not checked unless Channel 16 is set as a TAG channel.

Priority Scan: Priority scan searches through all TAG channels in sequence while monitoring Channel 16.

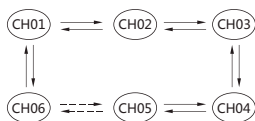

Normal Scan

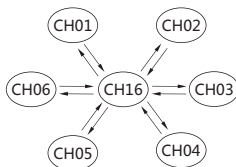

Priority Scan

■ Setting TAG Channels

For more efficient scanning, you can add desired channels as TAG channels or clear the TAG for unwanted channels.

Channels that are not tagged will be skipped during scanning.

◆ Setting / Clearing a Single Tagged Channel

1. Press [▲]/[▼] to select the channel you want to set as TAG channel.
2. Press [◀]/[▶] to display [TAG].
3. Press softkey [TAG] to set current channel as TAG channel.
 - "TAG" is displayed on screen.

4. To cancel the TAG channel setting, press softkey [TAG] again.
 - "TAG" disappears from the screen.

◆ Setting / Clearing All Tagged Channels

1. Press [MENU] key, the menu interface is displayed.
2. Press [▲]/[▼] or rotate [DIAL] knob to select "Radio Settings", then press [OK], the "RADIO SETTINGS" screen is displayed.
3. Press [▲]/[▼] or rotate [DIAL] knob to select "FAV Settings", then press [OK], the "FAV SETTINGS" screen is displayed.
4. Press [▲]/[▼] or rotate [DIAL] knob to select "Set All Channels" to set all channels as Tagged Channels.
5. Select "Clear All Channels" to cancel all the TAG channel setting.
6. Select "Set Default" to restore to factory default channel setting.

■ Starting a Scan

Scan Type, Weather Alert, Scan Timer can be set in the menu interface.

1. Press [◀]/[▶] to display [SCAN].
2. Press softkey [SCAN] to start Normal or Priority Scan.
 - "SCAN 16" is displayed during a Priority Scan, and "SCAN" is displayed during a Normal Scan.
 - When a signal is received, the scan pauses until the signal disappears, or resumes after 5 seconds, depending on the Scan Timer setting in "Radio Settings".
 - A beep sounds and "16" blinks when a signal is received on Channel 16 during a Priority Scan.
 - Press [▲]/[▼] to change the scanning direction.
3. To stop the scan, press softkey [SCAN] again.

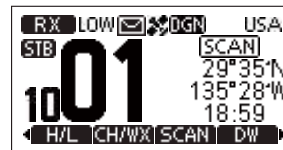

DUALWATCH / TRI-WATCH

■ Description

This radio has Dualwatch and Tri-watch.

Dualwatch monitors Channel 16 while you are receiving on another channel.

Tri-watch monitors Channel 16 and the Call channel while receiving on another channel.

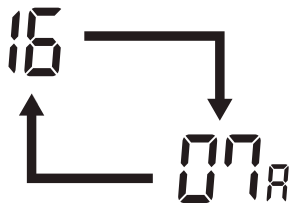

DUALWATCH

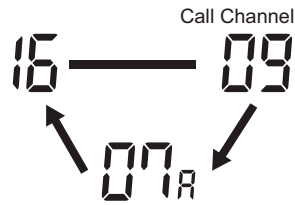

TRI-WATCH

■ Operation

1. Press softkey [**DW**] to start Dualwatch or Tri-watch.
 - “DW 16” is displayed during Dualwatch; “TW 16” is displayed during Tri-watch.
 - A beep tone sounds when a signal is received on Channel 16.
 - Tri-watch converts to Dualwatch when a signal is received on Call channel.
2. Press softkey [**DW**] again to cancel Dualwatch or Triwatch.



DSC OPERATION

■ MMSI Code Programming

The 9-digit MMSI (Maritime Mobile Service Identity: DSC self ID) code can be programmed by PC software and also manually set on this radio.

1. Press and hold **[PWR]** knob to power ON.
 - Three short beeps sound, and “Push **[OK]** to Register your MMSI” is displayed.
2. Press **[OK]** to start setting the MMSI code.
 - During the setup process, press **[BACK]** to skip the setting and return to normal operating mode, and you cannot make a DSC call.
3. Enter the MMSI code:
 - Press **[◀]/[▶]** to select the desired number.
 - Press **[OK]** to input the selected number.
 - Select “←” or “→”, or rotate **[DIAL]** to move the cursor, then press **[OK]**.

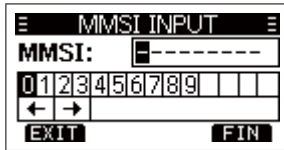

4. Repeat step 3 to enter all 9 digits.
5. After 9 digits have been input, press softkey **[FIN]** to set the code.
6. Enter MMSI code again to confirm.

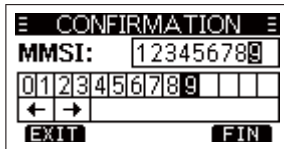

7. Repeat step 3 to 5 as above.
 - When your MMSI code input is successful, “MMSI Successfully Registered” is displayed as below.
 - Once setup is complete the radio can now perform normal operation.

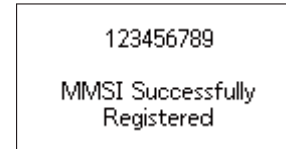

NOTE: In the menu interface, you can query the set MMSI code.

■ ATIS ID Programming

The Automatic Transmitter Identification System (ATIS) ID consists of 10 digits. You can enter the ATIS ID in the “ATIS ID Input” item on the Menu screen.

Entering the ATIS ID can only be done once via the radio, once entered it can only be changed via PC programming software.

1. Press **[MENU]** key, the menu interface is displayed.
2. Press **[▲]/[▼]** or rotate **[DIAL]** knob to select “ATIS Setting”, then select “ATIS ID Input”, then press **[OK]**, the “ATIS ID Input” screen is displayed.
3. Enter the ATIS ID:
 - Press **[◀]/[▶]** to select the desired number.
 - Press **[OK]** to input the selected number.
 - Select “←” or “→” to move the cursor, then press **[OK]**.

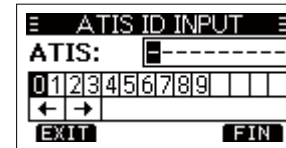

- Repeat step 3 to enter all 10 digits.
- After 10 digits have been entered, press softkey [**FIN**] to set the ID.
- Enter ATIS ID again to confirm.

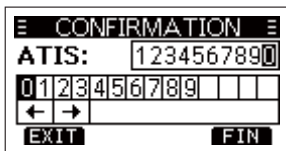

- Repeat step 3 to 5 as above.
 - Once setup is complete the radio can now perform normal operation.

NOTE: In the menu item "Radio Info", you can query the set ATIS ID.

■ DSC Address ID

Before using the DSC call related function, the DSC can be set as follows:

- Press [**MENU**] key, the menu interface is displayed.
- Press [**▲**]/[**▼**] or rotate [**DIAL**] knob to select "DSC Settings".
- Press [**OK**], the "DSC SETTINGS" screen is displayed.
- Press [**▲**]/[**▼**] or rotate [**DIAL**] knob to select the submenu item you want to set up.
 - The setting items includes Position Input, Individual ID, Goup ID, Auto ACK, CH Auto SW, Data Output, Alarm Status, CH 70 SQL Level, Self-Test, Multi-Task.
- Press [**OK**] to enter next level menu.
- Press [**BACK**] or softkey [**BACK**] to return to the previous menu. Press softkey [**EXIT**] to return to main interface.

◆ Entering the Position and Time

A Distress call should include the vessel's position and time. If no GPS data is received, manually input the position and Universal Time Coordinated (UTC) time.

- The manual entry is disabled while valid GPS data is received.
- The manually entered position and time is valid only for 23.5 hours, or until turning OFF the radio.

- Display the "POSITION INPUT" screen.
- Press [**▲**]/[**▼**]/[**◀**]/[**▶**] to enter longitude and latitude.
 - Press [**◀**]/[**▶**] to select desired number.
 - Press [**OK**] to enter.
 - Select "←" or "→", or rotate [**DIAL**] to move the cursor, then press [**OK**].
 - Move cursor to "N" or "S" to select N (North Latitude) or S (South Latitude).
 - Move cursor to "W" or "E" to select W (West Longitude) or E (East Longitude).

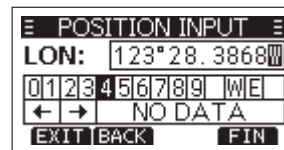
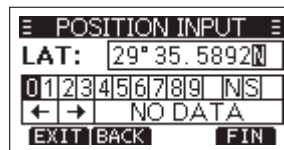

- After position is entered, press [**OK**] to confirm.
- In the UTC time editing interface, enter the UTC time as follows.
 - Press [**◀**]/[**▶**] to select desired number.
 - Press [**OK**] to enter.
 - Select "←" or "→", or rotate [**DIAL**] to move the cursor, then press [**OK**].

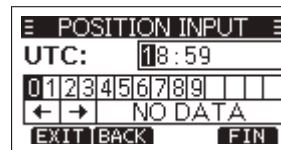

- Press softkey [**FIN**] to confirm position and time setting.
- Press softkey [**EXIT**] to return to standby interface.
 - The entered position and time are displayed on the operating screen.

◆ Entering an Individual ID

You can enter a total of 60 Individual IDs, and assign names to them of up to 10 characters.

1. Display the "INDIVIDUAL ID" screen.
 - "NO ID" is displayed if no ID is entered.
2. Press softkey [**ADD**], "INDIVIDUAL ID" entry screen is displayed.

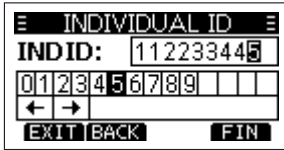

3. Enter an Individual ID:
 - Press [◀]/[▶] to select the desired number.
 - Press [OK] to input the selected number.
 - Select "←" or "→" to move the cursor, then press [OK].
 - * The first digit is fixed as "0" for a Group ID.
 - * The first two digits are fixed as "0" for any coast station ID.
4. Repeat step 3 to enter all 9 digits.
5. Then press softkey [**FIN**] to start entering the name.

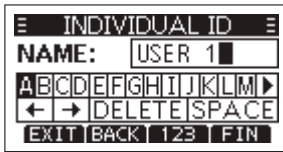

6. Enter an Individual ID Name:
 - Press [▲]/[▼]/[◀]/[▶] to select the desired characters.
 - Press [OK] to input the characters.
 - Select "←" or "→" to move the cursor, then press [OK].
 - Press [**123**]/[**!\$?**]/[**ABC**] to select numbers, characters and letters.

7. Then press softkey [**FIN**] to save, and return to the previous screen.
 - The entered Individual ID name is displayed.

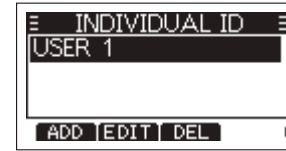

◆ Entering a Group ID

You can enter a total of 30 Group IDs, and assign names to them of up to 10 characters.

1. Display the "GPURP ID" screen.
 - "NO ID" is displayed if no ID is entered.
2. Press softkey [**ADD**], "GROUP ID" entry screen is displayed.

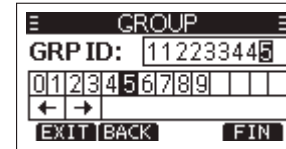

3. Enter an Group ID:
 - Press [◀]/[▶] to select the desired number.
 - Press [OK] to input the selected number.
 - Select "←" or "→" to move the cursor, then press [OK].
 - * The first digit is fixed as "0" for a Group ID.
 - * The first two digits are fixed as "0" for any coast station ID.
4. Repeat step 3 to enter all 9 digits.
5. Then press softkey [**FIN**] to start entering the name.

- Enter an Group ID Name:
 - Press [▲]/[▼]/[◀]/[▶] to select the desired characters.
 - Press [OK] to input the characters.
 - Select “←” or “→” to move the cursor, then press [OK].
 - Press [123]/[!\$?]/[ABC] to select numbers, characters and letters.
- Then press softkey [FIN] to save, and return to the previous screen.
 - The entered Group ID name is displayed.



◆ Deleting an Entered ID

- Display the “INDIVIDUAL ID” or “GPOUP ID” screen.
- Press [▲]/[▼] to select the ID you want to delete, then press softkey [DEL].
 - You can edit an ID and its name by pressing [EDIT].

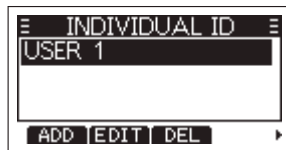

- Then press [OK] delete ID, and return to the previous screen.
 - Press [CANCEL] to cancel the deletion.

◆ Auto Acknowledgement (Auto ACK)

The Auto ACK function automatically sends an Acknowledgement call when an appropriate request is received. Auto Acknowledgement includes: Individual ACK, Position ACK, Polling ACK, Test ACK, the corresponding Acknowledgement mode setting options are shown in the following table:

ACK Type \ ACK Mode	Auto (Able)	Auto (Unable)	Auto	Manual
Individual ACK	Auto (Able)	Auto (Unable)		Manual
Position ACK	Auto (Able)			Manual
Polling ACK			Auto	Manual
Test ACK			Auto	Manual

◆ Channel Auto Switch (CH Auto SW)

Select whether or not to automatically switch to Channel 16 or the specified channel; or select whether to switch or ignore DSC call.

- Accept:** After receiving a DSC call, the radio remains on the operating channel for 10 seconds. After that, the radio automatically switches to the channel that is specified on the DSC call.
- Ignore:** After receiving a DSC call, if you do not press the softkey [ACPT] in 10 seconds, the radio ignores the call, and then remains on the current operating channel.
- Manual:** After receiving a DSC call, you can select whether or not to accept the received DSC call.

◆ Data Output

When receiving a DSC call from the station that is selected in this setting, the radio outputs the DSC data to the NMEA output port.

NOTE: You can send Distress calls independent of these settings.

- All Stations:** From any station.
- Station List:** From the stations that are entered Individual ID or Group ID on the Menu screen.
- OFF:** Does not output any DSC data from the NMEA 0183 Output port.

◆ Alarm Status

Set the alarm ON or OFF for each DSC related item. The factory default setting for each type is: ON.

- **Safety:** An alarm sounds when a Safety DSC call is received.
- **Routine:** An alarm sounds when a Routine DSC call is received.
- **Warning:** An alarm sounds when:
 - * No MMSI code is entered.
 - * The position data has not been received for 2 minutes after turning ON the radio.
 - * The received position data has not been updated for 10 minutes.
 - * The received position data has not been updated for 4 hours.
 - * The manually entered position data has not been updated for 23.5 hours.
- **Self-Terminate:** An alarm sounds when duplicate DSC calls are received.
- **Discrete:** An alarm sounds when a lower priority call is received while receiving a high priority call.

◆ CH 70 SQL Level

Adjust the Squelch level for Channel 70 to between 1 and 10, or open.

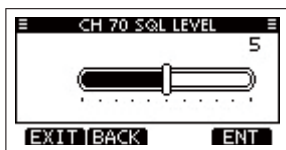

◆ Self-Test

The Self-Test sends DSC signals to the receiving AF circuit to compare the sending and receiving signals at the AF level.

1. Display the "SELF-TEST" screen.
2. Press softkey [**ENT**] or [**OK**] key to start the Self-Test.
 - When the transmitting and receiving DSC signals match, "OK" is displayed.
 - If "NG" is displayed, that means there is a problem with at least one of the transmitting DSC and the receiving DSC circuit. Contact Oricom Support should the transceiver be faulty.

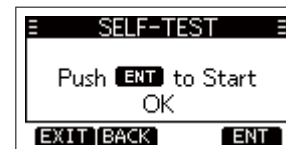
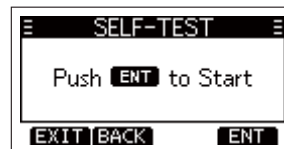

◆ Multi-Task

You can select the type of task for the radio, depending on the presetting.

- **Single:** Handles only 1 task at the same time.
- **Multiple:** Handles up to 7 tasks at the same time.

■ Distress Call

A Distress call should be sent if the ship or a person is in distress and requires immediate assistance.

NEVER make a Distress call if your ship or a person is not in an emergency. A Distress call should be made only when immediate help is needed.

◆ Distress Call Softkey Description

While waiting for an Acknowledgement:

1. [**CANCEL**]: Cancels the Distress call and enables you to send a Cancel call.
2. [**RESEND**]: Enables you to resend the Distress call by holding down [**DISTRESS**] again.
3. [**PAUSE**]: Pauses the countdown to resend the next Distress call.
4. [**INFO**]: Displays the information of the Distress call that you have sent.

After receiving an Acknowledgement:

1. [**STBY**]: Closes the Distress operation, and returns to the operating screen.
2. [**HIST**]: Displays the "DISTRESS HISTORY".
3. [**INFO**]: Display the information of the received Distress Acknowledgement.

◆ Simple Call

1. Confirm that no Distress call is being received.
2. While lifting up the key cover, hold down **[DISTRESS]** for 3 seconds until you hear 3 short countdown beeps and a long beep sound.
 - The backlight blinks.

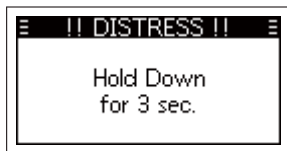
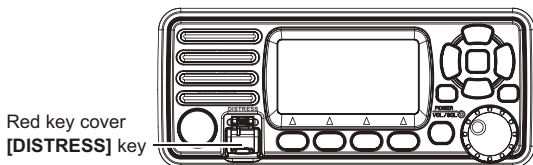

NOTE: When the radio does not receive any valid location data, the stored location data will be used for distress calls.

3. After sending, wait for an Acknowledgement call, "Waiting for ACK" is displayed.
 - The Distress call is automatically sent every 3.5~4.5 minutes, until an Acknowledgement is received, or a Distress Cancel call is sent.
 - Press softkey [**RESEND**] to manually resend the Distress call.
 - Press [**◀**]/[**▶**], then press softkey [**INFO**] to display the information of the Distress call that you have sent.
 - Press [**◀**]/[**▶**], then press softkey [**PAUSE**] to pause the countdown to resend the next Distress call, press [**RESUME COUNTDOWN**] to resume the countdown.



4. When you receive an Acknowledgement, an alarm sounds, press [**ALARM OFF**] to turn OFF the alarm.
5. Hold down **[PTT]**, and then talk to explain your situation.
6. After you have finished your conversation, then press [**CANCEL**] to return to the operating screen.

A default Distress alert contains:

- Nature of Distress: Undesignated distress.
- Position Information: The latest GPS, or manually entered position, which is held for 23.5 hours, or until transceiver is powered off.

◆ Regular Call

Select the nature of the Distress call to include in the Regular Distress call.

1. Press softkey [**DIST CALL**] or [**DTRS**], the "DISTRESS" screen is displayed.
2. Press **[OK]** or softkey [**ENT**] to enter the Nature selection mode.
3. Press [**▲**]/[**▼**] or rotate **[DIAL]** knob to select the nature of the Distress, then press **[OK]** or softkey [**ENT**].
 - If no valid GPS data is being received, press [**▲**]/[**▼**] or rotate **[DIAL]** knob to select "Position", then enter the latitude, longitude and UTC.
 - The nature of distress includes Undesignated, Fire, Explosion, Flooding, Collision, Grounding, Capsizing, Sinking, Adrift, Abandoning Ship, Piracy, Man Overboard.



- While lifting up the key cover, hold down **[DISTRESS]** for 3 seconds until you hear 3 short countdown beeps and a long beep sound.

- The backlight blinks.

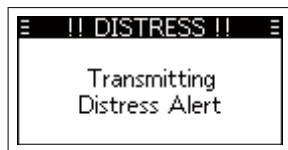
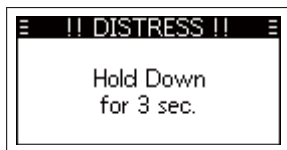

- After sending, wait for an Acknowledgement call, "Waiting for ACK" is displayed.

- The Distress call is automatically sent every 3.5~4.5 minutes, until an Acknowledgement is received, or a Distress Cancel call is sent.
- Press softkey [**RESEND**] to manually resend the Distress call.
- Press [**◀/▶**], then press softkey [**INFO**] to display the information of the Distress call that you have sent.
- Press [**◀/▶**], then press softkey [**PAUSE**] to pause the countdown to resend the next Distress call, press [**RESUME COUNTDOWN**] to resume the countdown.

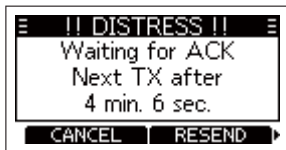

- When you receive an Acknowledgement, an alarm sounds, press [**ALARM OFF**] to turn OFF the alarm, then hold down **[PTT]** to communicate.



A default Distress alert contains:

- Nature of Distress: Select as per Step 2.
- Position Information: The latest GPS, or manually entered position, which is held for 23.5 hours, or until transceiver is powered off.

◆ Distress Cancel Call

If you have accidentally made a Distress call, or made an incorrect Distress call, send a Distress Cancel call to cancel the call as soon as possible while waiting for an Acknowledgement call, be sure to report the purpose of the cancellation.

- While waiting for an Acknowledgement call, press softkey [**CANCEL**].



- Press softkey [**CONTINUE**], to send Distress Cancel call.
- Channel 16 is automatically selected.
- Hold down **[PTT]** to report the purpose of the cancellation.
 - You can display the wording of the cancellation by press [**▼**].

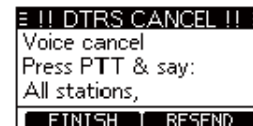

- After communicating, press softkey [**FINISH**].

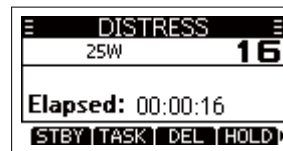

- Press softkey [**STBY**] to finish the Distress Cancel call, returns to the operating screen.

◆ Receiving DSC Calls (Distress)

The radio receives Distress calls, Distress Acknowledgement calls and Distress Cancel calls. The following steps are described using an example of receiving a Distress call. When a Distress call is received:

- The emergency alarm sounds until you turn it OFF.
 - "RCVD DISTRESS" is displayed, screen backlight blinks.
1. Press softkey [**ALARM OFF**] to turn OFF the alarm and screen backlight blinks.

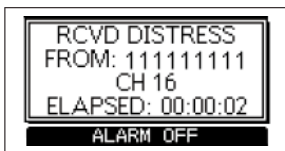

2. Press the softkey below the intended operation.



- **Ignore** [**IGN**]
 - Ignore the call and return to the operating screen.
 - The call is saved in the DSC Log.
 - "☒" blinks continuously until you display the call message.
- **Pause** [**PAUSE**]
 - [**PAUSE**] is not displayed if the "CH Auto SW" item is set to "Manual".
 - Pause the countdown until the assigned channel is automatically selected.
 - Select softkey [**RESUME**] to resume the countdown.
 - The call is saved in the DSC Log.
- **Accept** [**ACPT**]
 - Accept the call.
 - Channel 16 is automatically selected.

- Monitor Channel 16 as a coast station may require assistance.
- After Channel 16 is selected, you can select your next operation by pressing the softkey below the following options.

- **Return** [**EXIT**]
 - Returns to the operating screen.
- **History** [**HIST**]
 - Displays the "DISTRESS HISTORY" screen.
- **Information** [**INFO**]
 - Displays the information of the received Distress call.

■ Individual Call

An Individual call enables you to send a DSC signal to a specific station only.

◆ Sending an Individual Call

1. Press softkey [**DSC CALL**], the "OTHER DSC" screen is displayed.

NOTE: You can also display the "OTHER DSC" screen by selecting the "DSC Call" item on the Menu screen.

2. Select "Type", then press [**OK**].
3. Select "Individual", then press [**OK**] or softkey [**ENT**].
 - Returns to the "OTHER DSC" screen.
4. Select "Address", then press [**OK**] or softkey [**ENT**].
5. Select the station to send an Individual call to, then press [**OK**] or softkey [**ENT**].
 - Returns to the "OTHER DSC" screen.

NOTE: You can also select "Manual Input" to manually enter the target station.

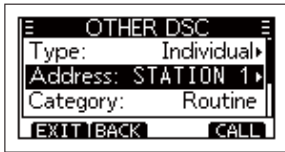

6. Select "Channel", then press **[OK]** or softkey **[ENT]**.
7. Select a channel to assign, and then press **[OK]** or softkey **[ENT]**.
 - The assigned channels are preset by default.



8. Press softkey **[CALL]** to send the Individual call.
 - "Transmitting Individual Call" is displayed, and then "Waiting for ACK" is displayed.

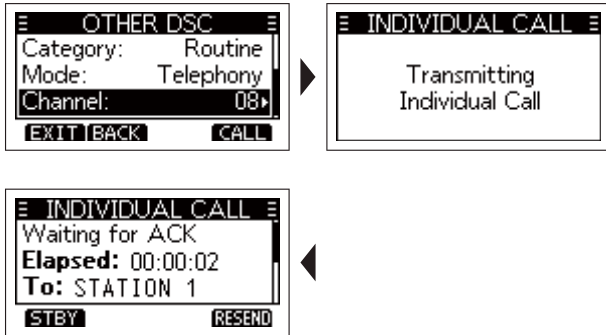

9. When you receive an Acknowledgement "Able to comply", an alarm sounds, the screen as below is displayed.



Press softkey **[ALARM OFF]** to turn OFF the alarm, the channel assigned in above step is automatically selected.

- If the called station cannot use the channel that you assigned, a different channel is selected by the station.
- Hold down **[PTT]** to communicate.

When you receive an Acknowledgement "Unable to comply", an alarm sounds, the Acknowledge information is displayed. Press **[STBY]**, then press **[OK]** to return to the operating screen.

10. After communication, press softkey **[EXIT]** to return to the operating screen.

◆ Sending an Individual Acknowledgement

When you have received an Individual call, send an Acknowledgement to the calling station, select "Able to Comply", "Propose New CH" or "Unable to Comply".

1. While an Individual call is being received, an alarm sounds, the screen as below is displayed. Press softkey **[ALARM OFF]** to turn OFF the alarm.



2. Press softkey **[ACPT]**, the Acknowledgement category screen is displayed.
 - If you want to send an Acknowledgement "Able to Comply" right away, press softkey **[ABLE]**.
 - If you cannot communicate, and want to return to the operating screen, press **[IGN]**.

- Press softkey [**IGN**] [**UNABLE**] [**NEWCH**] to select the Acknowledgement type.



- **ABLE (Able to Comply)**: Sends an Acknowledgement call without any changes.
- **UNABLE (Unable to Comply)**: Sends an Acknowledgement call but cannot communicate.
- **NEWCH (Propose New CH)**: Able to communicate but proposes another channel. Specify the channel by press [▲] or [▼] (Example: Channel 68).



- Press softkey [**CALL**] to send the Acknowledgement call.

◆ Receiving an Individual Call

When an Individual call is received:

- The alarm sounds.
- "RCVD INDIVIDUAL" is displayed.

- Press softkey [**ALARM OFF**] to turn OFF the alarm.



- Press the softkey for the next operation.



- Press [**IGN**]: Ignores the call and returns to the operating screen.
 - "☒" blinks continuously until you display the call message.
 - The call is saved in the DSC Log.
- Press [**ABLE**]: Able to comply, sends an Individual Acknowledgement call right away.
 - The assigned channel is automatically selected.
 - After sending, press [**RESEND**] to resend.
 - The call is saved in the DSC Log.
- Press [**ACPT**]: Accepts the call.
 - The assigned channel is automatically selected.
 - The call is saved in the DSC Log.
 - The received call's information is displayed.
 - Press the softkey to select the Acknowledgement option.



ABLE (Able to Comply): Sends an Acknowledgement call without any changes.

UNABLE (Unable to Comply): Sends an Acknowledgement call but cannot communicate.

NEWCH (Propose New CH): Able to communicate but proposes another channel. Specify the channel by press [▲] or [▼].

NOTE: If the Auto ACK function is set to “Auto (Unable)”, the Acknowledgement “Unable to Comply” is automatically sent to the calling station when the call is received. This function is set to “Auto (Able)” by default.

■ Group Call

A Group call enables you to send a DSC call to only a specific group. A group of fleets corresponds to a group call identification code, and the entire fleet will be called when the group calls.

◆ Sending a Group Call

You can send a Group call to a pre-entered group address, or manually enter the address before sending.

1. Press softkey [**DSC CALL**], the “OTHER DSC” screen is displayed.

NOTE: You can also display the “OTHER DSC” screen by selecting the “DSC Call” item on the Menu screen.

2. Select “Type”, then press [**OK**], “MESSAGE TYPE” is displayed.
3. Select “Group”, then press [**OK**] or softkey [**ENT**].
 - Returns to the “OTHER DSC” screen.



4. Select “Address”, then press [**OK**].
5. Select the group to send an Group call to , then press [**OK**].

NOTE: You can also select “Manual Input” to manually enter the target group.

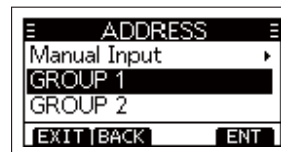

6. Select “Channel”, then press [**OK**].
7. Select a channel to assign, and then press [**OK**] or softkey [**ENT**].
 - The assigned channels are preset by default.



8. Press softkey [**CALL**] to send the Group call.
 - “Transmitting Group Call” is displayed, and then the assigned channel is automatically selected.

NOTE: If Channel 70 is busy, the radio stands by until the channel becomes clear.

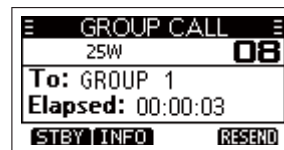
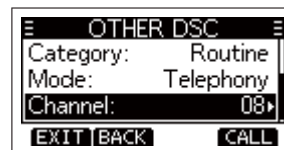



9. Hold down [**PTT**] to communicate.

◆ Receiving an Group Call

When a Group call is received:

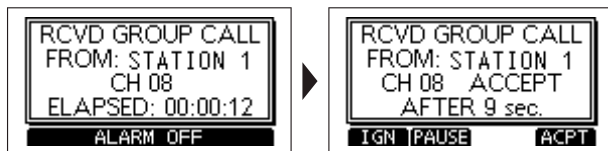
- The alarm sounds for 2 minutes.
- “RCVD GROUP CALL” is displayed.
 1. Press softkey [**ALARM OFF**] to turn OFF the alarm.
 - The channel that is assigned by the caller is automatically selected after 10 seconds by default.
 2. Press the softkey for the next operation.



- Press [**IGN**]: Ingores the call and returns to the operating screen.
- “” blinks continuously until you display the call message.
 - The call is saved in the DSC Log.
- Press [**PAUSE**]: Pauses the countdown until the assigned channel is automatically selected.

NOTE: [**PAUSE**] is not displayed if the “CH Auto SW” item is set to “Manual”.

- Select [**RESUME**] to resume the countdown.
 - The call is saved in the DSC Log.
- Press [**ACPT**]: Accepts the call.
- The assigned channel is automatically selected.
 - The call is saved in the DSC Log.
- Press [**STBY**]: Closes the Group call, then returns to the operating screen.
- Press [**INFO**]: The receiver call’s information is displayed.

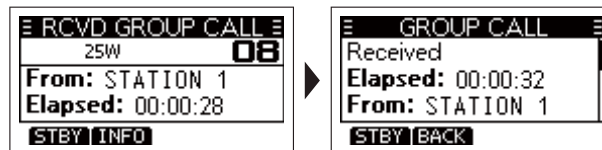

■ All Ships Call

An All Ships call enables you to announce a message to all the ships within range.

◆ Sending an All Ships Call

1. Press softkey [**DSC CALL**], the “OTHER DSC” screen is displayed.

NOTE: You can also display the “OTHER DSC” screen by selecting the “DSC Call” item on the Menu screen.

2. Select “Type”, then press [**OK**], “MESSAGE TYPE” is displayed.
3. Select “All Ships”, then press [**OK**] or softkey [**ENT**].
 - Returns to the “OTHER DSC” screen.

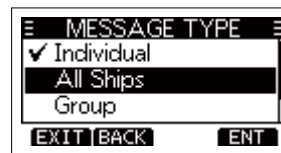

4. Select “Category”, then press [**OK**].
5. Select a category of the call, then press [**OK**] or softkey [**ENT**].
6. Select “Channel”, then press [**OK**].
7. Select a channel to assign, and then press [**OK**] or softkey [**ENT**].
 - The assigned channels are preset by default.

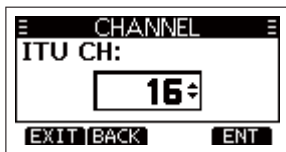

- Press softkey [**CALL**] to send the All Ships call, "Transmitting All Ships Call" is displayed, and then the assigned channel is automatically selected.

NOTE: If Channel 70 is busy, the radio stands by until the channel becomes clear.

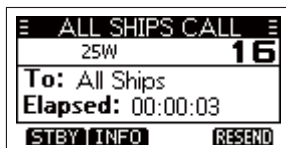

- Hold down [**PTT**] to communicate.

◆ Receiving an All Ships Call

When an All Ships call is received:

- The alarm sounds
- "RCVD ALL SHIPS CALL" is displayed.

- Press softkey [**ALARM OFF**] to turn OFF the alarm.
 - The channel that is assigned by the caller is automatically selected after 10 seconds by default.

- Press the softkey for the next operation.



- Press [**IGN**]: Ignores the call and returns to the operating screen.

- The call is saved in the DSC Log.
- " " blinks continuously until you display the call message.

- Press [**PAUSE**]: Pauses the countdown until the assigned channel is automatically selected.

NOTE: [**PAUSE**] is not displayed if the "CH Auto SW" item is set to "Manual".

- Press [**ACPT**]: Accepts the call.

- The assigned channel is automatically selected.
- The call is saved in the DSC Log.

- Press [**STBY**]: Closes the All Ships call, then returns to the operating screen.

- Press [**INFO**]: The receiver call's information is displayed.



■ Position Request Call / Polling Request Call

When you want to know information about the current location of a ship, you can send a Position Request call.

◆ Sending a Position Request Call/ Polling Request Call

1. Press softkey [**DSC CALL**], the "OTHER DSC" screen is displayed.

NOTE: You can also display the "OTHER DSC" screen by selecting the "DSC Call" item on the Menu screen.

2. Select "Type", then press [OK], "MESSAGE TYPE" is displayed.
3. Select "Position", then press [OK] or softkey [**ENT**].
 - The message type is selected, and returns to the "OTHER DSC" screen.

NOTE: When you send a Polling Request call, select "Polling".

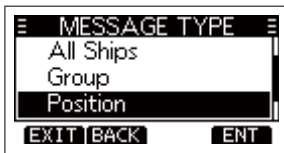

4. Select "Address", and then press [OK].
5. Select a target to send a Position Request call to, and then press [OK] or softkey [**ENT**].

NOTE: You can also select "Manual Input" to manually enter the target ID.

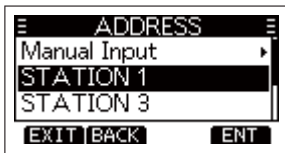

6. Press softkey [**CALL**] to send the Position Request call.
 - "Transmitting Position Request" is displayed, and then the assigned channel is automatically selected.

NOTE: If Channel 70 is busy, the radio stands by until the channel becomes clear.

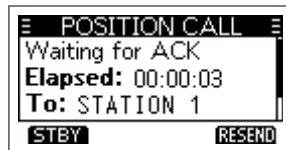
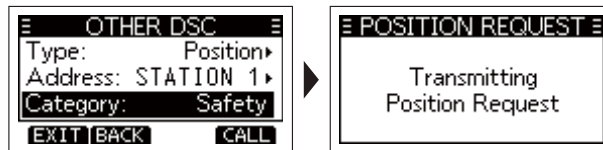

7. When you receive a Position Reply:
 - An alarm sounds.



8. Press softkey [**ALARM OFF**] to turn OFF the alarm.
9. Press softkey [**CLOSE**], the received information is displayed.
10. Press [▲]/[▼] to scroll the screen then check the target's position.
11. Press softkey [**STBY**], and then press [**OK**] to return to the operating screen.

◆ Receiving a Position Request Call/Polling Request Call

When an Position Request call is received:

- The alarm sounds for 2 minutes.
- “RCVD POS REQUEST” is displayed.
 1. Press softkey [**ALARM OFF**] to turn OFF the alarm.
 2. Press the softkey for the next operation.

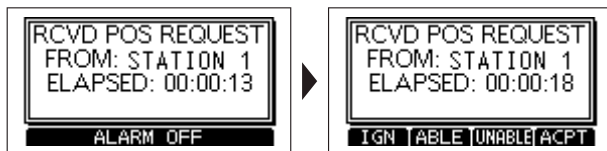

- Press [**IGN**]: Ingores the call and returns to the operating screen.
 - The call is saved in the DSC Log.
 - “✉” blinks continuously until you display the call message.
- Press [**ABLE**]: Sends the Acknowledgement “Able to Comply”.
 - The call is saved in the DSC Log.
- Press [**UNABLE**]: Sends the Acknowledgement “Unable to Comply”.
 - Displays the Acknowledgement information, and then press [**EXIT**] to return to the operating screen.
 - The call is saved in the DSC Log.
- Press [**ACPT**]: Accepts the call.
 - The received call's information is displayed.
 - The call is saved in the DSC Log.
 - Press [**ABLE**] or [**UNABLE**], then press [**CALL**] to send the Position Reply call.

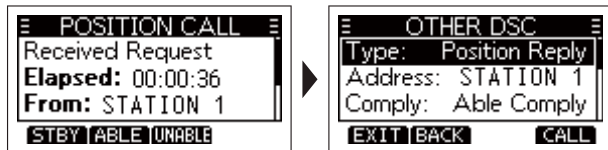

NOTE:

- If the Auto ACK function in “DSC Settings” is set to “Auto”, the Position Reply is automatically sent to the calling station.
- However, even if the Auto ACK function is set to “Manual”, after receiving a Distress Acknowledgement, or while in the Distress Cancel call procedure, the Position Reply is automatically sent to the calling station.

◆ Sending a Position Reply Call

Send a Position Reply call when a Position Request call is received. If the Auto ACK function in “DSC Settings” is set to “Auto”, the Acknowledgement is automatically sent to the calling station.

1. While a Position Request call is being received, press softkey [**ALARM OFF**] to turn OFF the alarm.



2. Press softkey [**ACPT**], the received call's information is displayed.



3. Press softkey [**ABLE**] to send an “Able to Comply” Acknowledgement, or press softkey [**UNABLE**] to send an “Unable to Comply” Acknowledgement.

NOTE: If no valid GPS position is received, you can manually enter the position and time in “Position” item on this screen. See “Entering the position and time” for details.



4. Press softkey [**CALL**] to send the Position Reply call.

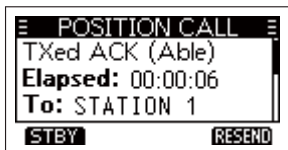
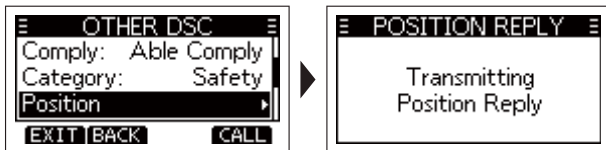

5. Press softkey [**STBY**], and then press [**OK**] to return to the operating screen.

■ Test Call

You should avoid testing calls on the specific DSC distress channels and safety calling channels. When you cannot avoid testing on a distress or safety channel, you should indicate that these are test calls. Normally the test call would require no further communication between the two stations involved.

◆ Sending a Test Call

1. Press softkey [**DSC CALL**], the "OTHER DSC" screen is displayed.

NOTE: You can also display the "OTHER DSC" screen by selecting the "DSC Call" item on the Menu screen.

2. Select "Type", then press [**OK**], "MESSAGE TYPE" is displayed. Select "Test", then press [**OK**] or softkey [**ENT**].



3. Select "Address", and then press [**OK**].

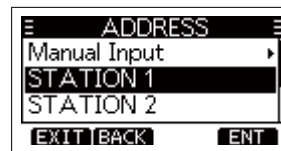

4. Select a station to send the Test call to.

NOTE: You can also select "Manual Input" to manually enter the calling station.

5. Press softkey [**CALL**] to send the Test call, "Transmitting Test Call" is displayed.

NOTE: If Channel 70 is busy, the radio stands by until the channel becomes clear.

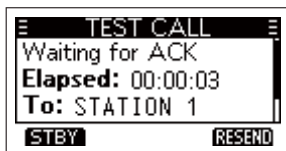
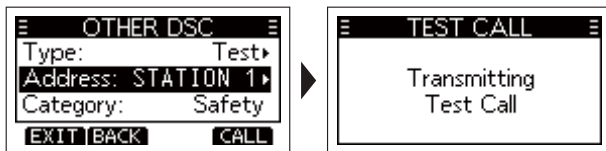

6. When you receive an Acknowledgement:
- An alarm sounds, the screen is displayed as below.



7. Press softkey [**ALARM OFF**] to turn OFF the alarm.
8. Press softkey [**STBY**], "Terminate the procedure. Are you sure?" is displayed.
9. Press softkey [**OK**] to return to the operating screen.

◆ Receiving a Test Call

By default, the Auto ACK function automatically sends an Acknowledgement to the calling station. If the function is set to "Manual", the following is displayed.

When a Test call is received:

- The alarm sounds for 2 minutes.
- "RCVD TEST CALL" is displayed.
 1. Press softkey [**ALARM OFF**] to turn OFF the alarm.
 2. Press the softkey for the next operation.

→ Press [**IGN**]: Ignores the call and returns to the operating screen.

- The call is saved in the DSC Log.
- "✉" blinks continuously until you display the call message.

→ Press [**ABLE**]: Sends the Acknowledgement "Able to Comply".

- The call is saved in the DSC Log.

→ Press [**ACPT**]: Accepts the call.

- The received call's information is displayed.
- The call is saved in the DSC Log.
- Press softkey [**ACK**], then press [**CALL**] to send a Test Acknowledgement call.
- Press softkey [**RESEND**] to resend.

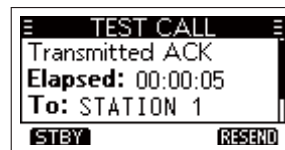

NOTE: If the Auto ACK function in "DSC Settings" is set to "Auto", the Test Acknowledgement call is automatically sent to the calling station when the call is received.

◆ Sending a Test Acknowledgement Call

By default, when you receive a Test call, the Auto ACK function automatically sends an Acknowledgement to the calling station. If the function is set to "Manual", do the following steps to send an Acknowledgement.

1. After a Test call is being received, press [**ALARM OFF**] to turn OFF the alarm.
2. Press softkey [**ACPT**], the received call's information is displayed.
3. Press softkey [**ACK**], the "Test ACK" confirmation screen is displayed.

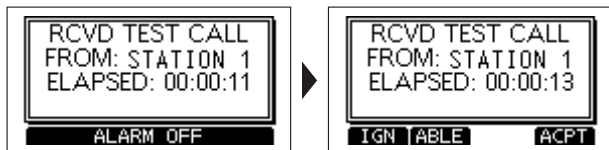

4. Press softkey [**CALL**] to send the Acknowledgement, "Transmitting Test Ack" is displayed.

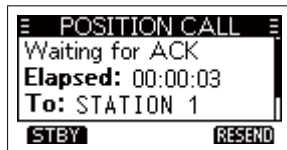
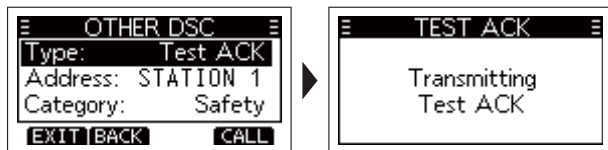

5. Press softkey [**STBY**], a confirmation screen is displayed.

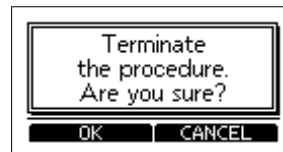

6. Press [**OK**] to return to the operating screen.

◆ Receiving a Test Acknowledgement Call

After sending a Test call, the called station will send you a Test Acknowledgement call.

When a Test Acknowledgement call is received:

- The alarm sounds for 2 minutes.
- "RCVD TEST ACK" is displayed.



1. Press softkey [**ALARM OFF**] to turn OFF the alarm.
2. Press softkey [**CLOSE**], the received call's information is displayed.
 - The call is saved in the DSC Log.



3. Press [**STBY**] to return to the operating screen.

■ DSC Log

◆ Received DSC Log

The radio saves up to 30 received Distress call messages and 50 received “Other” call messages in your DSC Log. On the operating screen, “

1. Press softkey [**LOG**] to display the “RCVD CALL LOG” screen.

NOTE: You can also enter “RCVD CALL LOG” screen by menu operation, steps as below:

Menu → **DSC Log** → **Received Call Log**

2. Press [**▲**]/[**▼**] to select “Distress” or “Others”, then press [**OK**] or softkey [**ENT**].

NOTE:

- **Distress:** Displays the received Distress call log.
- **Others:** Displays the received DSC call log.

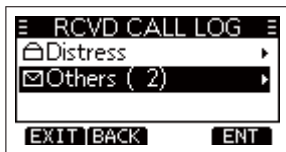

3. Press [**▲**]/[**▼**] to scroll through the log.
4. Press softkey [**ENT**] to display the received call's information.

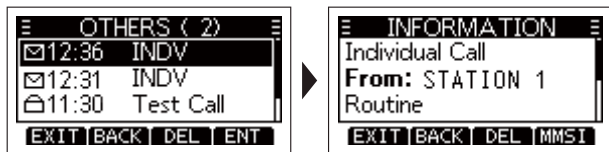

- Press [**EXIT**]: Returns to the operating screen.
- Press [**BACK**]: Returns to the previous screen.
- Press [**DEL**]: Deletes the selected call log.

NOTE: The confirmation screen is displayed before deleting.

- Press [**MMSI**]: Saves the MMSI as an Individual ID.

◆ Transmitted DSC Log

The radio saves up to 30 DSC transmitted calls in your DSC Log.

1. Press [**MENU**], then press [**▲**]/[**▼**] to select “DSC Log”, and then press [**OK**].
2. Press [**▲**]/[**▼**] to select “Transmitted Call Log”, then press [**OK**] or softkey [**ENT**].
 - The “TX CALL LOG” screen is displayed.
3. Press [**▲**]/[**▼**] to scroll through the log.
4. Press softkey [**ENT**] to display the sent call's information.

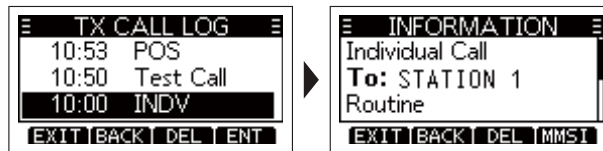

- Press [**EXIT**]: Returns to the operating screen.
- Press [**BACK**]: Returns to the previous screen.
- Press [**DEL**]: Deletes the selected call log.

NOTE: The confirmation screen is displayed before deleting.

- Press [**MMSI**]: Saves the MMSI as an Individual ID or a Group ID.

■ Multiple-task Mode

If the Multiple-task function is enabled, the radio can hold up to 7 tasks. Therefore, you can handle more than 2 DSC tasks simultaneously by switching between the DSC tasks.

◆ Setting Multiple-task Mode

1. You can enter "MULTI-TASK" screen by menu operation, steps as below:
Menu → DSC Settings → Multi-Task
2. Press [▲]/[▼] to select required multi-task mode, then press [OK] or softkey [ENT].

NOTE:

- **Single:** Single task mode, you can handle one DSC task.
 - **Multiple:** Multi-task mode, you can handle more than 2 DSC tasks.
- When the Multiple-task mode is activated, [TASK] is displayed on the operating screen.

NOTE: The Task mode has a Time-out Timer (TOT) function. After a certain period of time has passed without any operation on a task, the radio automatically exits the Task mode and returns to the operating screen. When a Time-out Timer (TOT) activates, an alarm sounds and a countdown message is displayed for 10 seconds.

◆ Holding a DSC Task

In the Multiple-task mode, you can hold or activate the DSC task, operations as follows.

Example: When a Group call is received,

1. Press softkey [ALARM OFF] to turn OFF the alarm.
 - The received call's information is displayed.
2. Press softkey [HOLD].
 - The received Group call task is held into the task list and returns to the operating screen.

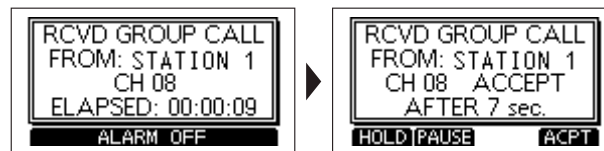

◆ Activating the Held DSC Task

1. Press softkey [TASK] to display the task list.
2. Press [▲]/[▼] to select the task that you want to activate.
3. Press softkey [ACTIVE] to activate the task.
 - The activated task information is displayed.

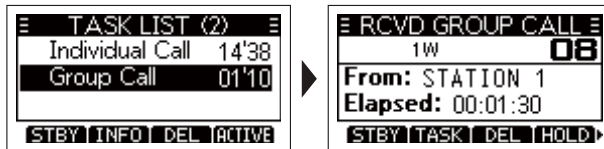

4. Press [PTT] to communicate.
5. After finishing the communication, press softkey [DEL] to delete the task.

◆ Task List

When one or more tasks are held, you can display the task list screen by pressing softkey [**TASK**], the number of tasks is displayed at the top of the screen.

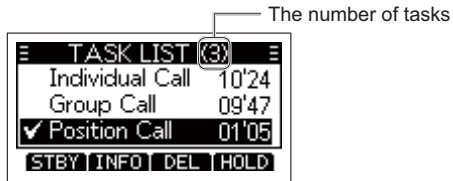

On the "TASK LIST" screen, the following softkeys are displayed.

- Press [**STBY**]: Holds the task and returns to the operating screen.
- Press [**INFO**]: Displays the task information.
- Press [**DEL**]: Deletes the selected task.
- Press [**HOLD**]: Holds the selected task.
- Press [**ACTIVE**]: Activates the selected task.

MENU SCREEN OPERATION

Menu Screen Operation

The Menu screen is used to select options and change settings.

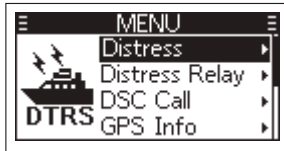

◆ Entering Menu Screen Operation

1. Press **[MENU]**, the Menu screen is displayed.
2. Press **[▲]/[▼]** to select the required menu item, then press **[OK]** to confirm, or to enter next level menu.
 - Repeat this operation to enter all levels of menu items.
3. Press **[BACK]** or softkey **[BACK]** to return to the previous screen.
4. Press softkey **[EXIT]** to exit the Menu screen.

Menu Screen Items

The Menu screen contains the following items.

Main Menu Item	Submenu Item	Display	Ref.
Distress	Nature of Distress	Nature	25
	Position	Position	19
DSC Call	Type	Type	27
	Address	Address	27
	Category	Category	27
	Mode	Mode	27
	Channel	Channel	27

GPS Info (Display Position Info)	Source	Source	-
	Latitude	LAT	
	Longitude	LON	
	UTC Time	UTC	
	Speed	SOG	
	Course	COG	
Configuration	Backlight	Backlight	46
	Display Contrast	Display Contrast	47
	Key Beep	Key Beep	47
	Key Assignment	Key Assignment	47
	UTC Offset	UTC Offset	47
	Inactivity Timer	Inactivity Timer	47
	GPS Configuration	GPS	47
DSC Log	Received Call Log	Received Call Log	40
	Transmitted Call Log	Transmitted Call Log	40
Radio Settings	Scan Type	Scan Type	45
	Scan Timer	Scan Timer	45
	Dual/Tri-watch	Dual/Tri-watch	45
	Channel Group	Channel Group	45
	Call Channel	Call Channel	45
	Weather Alert	WX Alert	45
	Favorite Channel Settings	FAV Settings	45
	Favorite Channel Selection	FAV on MIC	46
	Channel Display Digit	CH Display	46
	Channel Close-up	CH Close-up	46

DSC Settings	Position Input	Position Input	19
	Individual ID	Individual ID	20
	Group ID	Group ID	21
	Auto Acknowledgement	Auto ACK	22
	Channel Auto Switch	CH Auto SW	22
	Data Output	Data Output	22
	Alarm Status	Alarm Status	22
	Channel 70 Squelch Level	CH 70 SQL Level	23
	Self-Test	Self-Test	23
	Multi-Task	Multi-Task	23
ATIS Settings	ATIS ON/OFF	ATIS ON/OFF	19
	ATIS ID Input	ATIS ID Input	19
Radio Info (Inquiry MMSI, ATIS and Ver. Info)	MMSI Code	MMSI	-
	ATIS Code	ATIS (Displays only when ATIS function is activated)	
	GPS Version	GPS Ver	
	Firmware Version	Firm Ver	
	Hardware Version	Hard Ver	

■ Radio Settings

No.	Setting Items	Setting Options	Defaults
1	SCAN TYPE	Normal Scan Priority Scan	Normal Scan
2	SCAN TIMER	ON/OFF	OFF
3	DUAL/TRI-WATCH	Dualwatch Tri-watch	Dualwatch
4	CHANNEL GROUP	USA/ INT/ CAN	USA
5	CALL CHANNEL	Channel 00~P3	Channel 09
6	WX ALERT	ON with Scan/ ON/OFF	OFF
7	FAV SETTINGS	Set All Channels/Clear All Channels/Set Default	-----
8	FAV ON MIC	ON/OFF	OFF
9	CH DISPLAY	3 Digits/ 4 Digits	3 Digits
10	CH CLOSE-UP	ON/OFF	OFF

◆ Scan Type

The radio has 2 scan types: Normal Scan and Priority Scan.

- **Normal Scan:** Scans all favourite channels in the selected channel group.
- **Priority Scan:** Sequentially scans all favourite channels while monitoring Channel 16.

◆ Scan Timer

Scan Timer can be set as OFF or ON.

When set to OFF, when a signal is detected on a channel, the scan pauses until the signal disappears, and then resumes.

When set to ON, when a signal is detected on a channel, the scan pauses for 5 seconds, and then resumes. If the signal disappears in less than 5 seconds, the scan immediately resumes.

◆ Dualwatch/Tri-watch

Select Dualwatch or Tri-watch, see corresponding chapter for details.

◆ Channel Group

Select the suitable channel group for your operating area, including USA, INT, CAN Channel Group.

◆ Call Channel

You can change your Call channel.

◆ WX Alert

When there is any important weather information, an NOAA broadcast station transmits a Weather Alert tone. While WX Alert function is ON, "WX☁️" is displayed instead of "WX". When detecting an alert, an alarm sounds and "WX☁️" blinks.

- **ON with Scan:** The preset Weather channels are sequentially checked while scanning.
- **ON:** The previously selected (last used) Weather channel is checked while scanning.
- **OFF:** The Weather Alert tone is not detected.

◆ FAV Settings

You can set all channels as favourite channels, clear all settings, or reset to default. By default, some channels are preset.

- **Set All Channels:** Sets all channels as favourite channels.
- **Clear All Channels:** Clears all favourite channels.
- **Set Default:** Resets favourite channels to the default.

◆ FAV on MIC

You can select the channel set when you press [▲]/[▼] on the supplied microphone.

◆ CH Display

- You can select the number of digits to display the channel number, 3 Digits or 4 Digits.

◆ CH Close-up

You can select whether or not to display the channel name when changing the operating channel. While the function is ON, when you press [▲]/[▼] to select channels, the selected channel number and name will display for 1 second, then return to normal screen.

■ Configuration

Items		Options	Defaults
BACKLIGHT		7 Levels/ OFF	Level 4
DISPLAY CONTRAST		Level 1~8	Level 3
KEY BEEP		ON/ OFF	ON
KEY ASSIGNMENT		Softkey 1~16	SCAN, DW/TW, CH/WX, H/L, ATT, VIB, TAG, NAME, BL, LOG
UTC OFFSET		-14:00~+14:00	00:00
INACTIVITY TIMER	Not DSC	Off, 1-15 min	10 min
	DSC	Off, 1-15 min	15 min
	Distress	Off, 1-15 min	OFF
	RT	10/30 sec, 1~10 min	30 sec
GPS	GPS	ON	ON
	GLONASS	ON/ OFF	ON
	SBAS	ON/ OFF	OFF

◆ Backlight

You can adjust the backlight brightness between 1 and 7, or OFF. When backlight function is ON, press any key (except for [PTT]), the backlight ON.

◆ Display Contrast

You can adjust the display contrast level between 1 (lowest) and 8 (highest).

◆ Key Beep

You can select whether or not to sound a beep when a key is pressed.

◆ Key Assignment

You can change which softkey functions to display, and their order.

1. Display the "KEY ASSIGNMENT" screen, press [**▲**]/[**▼**] to select the softkey you want to set up, then press [**OK**] to enter.
2. Press [**▲**]/[**▼**] to select the function you want to set up, then press [**OK**] to confirm setting.

◆ UTC Offset

You can set the offset time between UTC (Universal Time Coordinated) and your local time to between -14:00 and +14:00, in minute increments.

◆ Inactivity Timer

The radio automatically returns to the operation screen if no keys are selected for the set period of time for each mode.

- **Not DSC** (Default: 10 min)
Setting for when a screen that is not related to DSC is displayed.
- **DSC** (Default: 15 min)
Setting for when a screen that is related to DSC is displayed.
- **Distress** (Default: Off)
Setting for when a screen that is related to a Distress call is displayed.
- **RT** (Default: 30 sec)
Setting for when the radio is in the Radio Telephone mode.

◆ GPS

Selects a satellite to be used for GPS (Global Positioning System) to pinpoint the geographic location of your radio anywhere in the world.

- **GPS:** The GPS is permanently set to ON.
- **GLONASS:** Select whether or not to use the data from the GLONASS (GLObal'nyaya NAVigatsionnaya Sputnikovaya Sistema) satellites.
- **SBAS:** Turns the SBAS (Satellite Based Augmentation System) function ON or OFF. The SBAS transmits signals to correct errors, and improves accuracy and reliability in data received from regular GNSS satellites. When this function is ON, you can use the corrected data.

■ VHF MARINE RADIO CHANNEL LIST (Default International)

Channel number			Frequency (MHz)		Channel number			Frequency (MHz)		Channel number			Frequency (MHz)		Channel number			Frequency (MHz)							
USA	INT	CAN	Transmit	Receive	USA	INT	CAN	Transmit	Receive	USA	INT	CAN	Transmit	Receive	USA	INT	CAN	Transmit	Receive	USA	INT	CAN	Transmit	Receive	
	01	01	156.050	160.650	20	20	20 ¹	157.000	161.600	63A	63A	68	156.175	156.175		81			157.075	161.675					
01A	01A		156.050	156.050	20A	20A		157.050	157.050		64	64	156.225	160.825	81A	81A	81A	157.075	157.075						
	02	02	156.100	160.700		20B		RX Only	161.600			64A	156.225	156.225		82			157.125	161.725					
	03	03	156.150	160.750		21		157.050	161.650		65		156.275	160.875	82A	82A	82A	157.125	157.125						
	04		156.200	160.800	21A	21A	21A	157.050	157.050	65A	65A	65A ¹	156.225	156.275		83	83		157.175	161.775					
		04A	156.200	156.200			21B	RX Only	161.650		66		156.325	160.925	83A	83A	83A	157.175	157.175						
	05		156.250	160.850		22		157.100	161.700	66A	66A	66A ¹	156.325	156.325			83B	RX Only	161.775						
05A	05A	05A	156.250	156.250	22A	22A	22A	157.100	157.100	67 ²	67	67	156.375	156.375	84		84	157.225	161.825						
06	06	16	156.300	156.300		23	23	157.150	161.750	68	68	68	156.425	156.425	85		85	157.275	161.875						
	07		156.350	160.950	23A	23A		157.150	157.150	69	69	69	156.475	156.475	86		86	157.325	161.925						
07A	07A	07A	156.350	156.350			23B	RX Only	161.750	70 ³	70 ³	70 ³	156.525	156.525	87	87	87	157.375	157.375						
08	08	08	156.400	156.400	24		24	157.200	161.800	71	71	71	156.575	156.575	88	88	88	157.425	157.425						
09	09	09	156.450	156.450	25		25	157.250	161.850	72	72	72	156.625	156.625											
10	10	10	156.500	156.500			25B	RX Only	161.850	73	73	73	156.675	156.675											
11	11	11	156.550	156.550	26		26	157.300	161.900	74	74	74	156.725	156.725											
12	12	12	156.600	156.600	27	27	27	157.350	161.950			75 ¹	75 ¹	156.775	156.775										
13 ²	13	13 ¹	156.650	156.650		27A		157.350	157.350			76 ¹	76 ¹	156.825	156.825										
14	14	14	156.700	156.700	28	28	28	157.400	162.000	77 ²	77	77 ¹	156.875	156.875											
15 ²	15 ¹	15 ¹	156.750	156.750		28A		157.400	157.400		78		156.925	161.525											
16	16	16	156.800	156.800			28B	RX Only	162.000	78A	78A	78A	156.925	156.925											
17 ¹	17	17 ¹	156.850	156.850		60	60	156.025	160.625		78B		RX Only	161.525											
	18		156.900	161.500		61		156.075	160.675		79		156.975	161.575											
18A	18A	18A	156.900	156.900			61A	156.075	156.075	79A	79A	79A	156.975	156.975											
	19		156.950	161.550		62		156.125	160.725		79B		RX Only	161.575											
19A	19A	19A	156.950	156.950			62A	156.125	156.125		80		157.025	161.625											
	19B		RX Only	161.550		63		156.175	160.775	80A	80A	80A	157.075	157.075											

USA-USA Channel Group, INT-International Channel Group, CAN-Canadian Channel Group ¹ Low Power Only. ² Momentary High Power. ³ DSC Operation Only.

■ SPECIFICATIONS

General	
Frequency Range	TX: 156.000~162.000MHz
	RX: 156.000~163.425MHz
Modulation	FM (16K0G3E), DSC (16K0G2B)
Frequency Stability	±5ppm
Operating Voltage	DC13.8V (±15%)
Operating Temperature	-20°C~+60°C
Antenna Impedance	50Ω
Dimensions (W×H×D)	155mm×68mm×86mm
Weight	721g (Hand MIC Included)

Transmitter	
Output Power	25W \ 1W
Max. Frequency Deviation	±5kHz
Spurious Emissions	≤-70dB (H)
	≤-56dB (L)
Adjacent Channel Power	≥70dB
Audio Harmonic Distortion	≤10%
Current Consumption	≤5.5A (H)
	≤1.5A (L)
Input Impedance	2kΩ (MIC)

Receiver	
Receive Sensitivity	≤0.22μV
Squelch Sensitivity	≤0.22μV
Adjacent Channel Selectivity	≥70dB
Spurious Response Rejection Ratio	≥70dB
Intermodulation Rejection Ratio	≥70dB
Max. Receive Current	≤1.5A
Audio Output Power	≥4.5W (10%)
GPS Signal Format	NMEA 0183-2.0
Output Impedance	4Ω (Speaker)

■ TROUBLESHOOTING

The problems described in the following table are some common operating faults. These types of errors are generally caused by improper connections, incorrect operation settings, or operational errors due to incomplete programming. These problems are usually not caused by circuit failures. Before you suspect that the radio has malfunctioned, please refer to these tables and relevant parts of this manual.

Problem	Possible Cause	Solution	Ref.
The radio does not turn ON.	1. The power cable is not connected well. 2. The power cable fuse is broken. 3. Operating voltage is more than 17V or less than 9V.	1. Check the power cable is connected correctly: red (+); black (-). 2. Find the cause of the blown fuse, replace the new fuse with 15A current. 3. Adjust the power supply to 13.8V.	3
Unable to connect with GPS.	1. Connection error. 2. External GPS format is different.	1. Check the connection is correct. 2. External GPS format should be NMEA 0183-2.0 or 3.01.	3
Unable to scan.	No TAG channel set.	Set the channels you want to scan as TAG channel.	15
Unable to transmit.	Work on Weather Channel or Channel 70 or RX Only Channels.	Exit the weather channel or channel 70 or RX Only Channel, select other channels.	11
Can't select high power.	Some channels can only be transmitted at low power.	Select other channels.	11
Can't communicate on same channel.	1. The channel is duplex (DUP). 2. Working in a self-set channel group.	1. Select channel. 2. Set the channel frequency to the same.	11
No beep.	Beep tones are turned OFF.	Turn the beep tone ON in the Set mode.	47
Distress call cannot be transmitted.	MMSI (DSC self ID) code is not programmed.	While pressing and holding [MENU] , power on to enter MMSI set mode.	18
No sound from the speaker.	1. Squelch level is too high. 2. The volume is too low. 3. Speaker grill water penetration.	1. Press [DIAL] knob twice and rotate to adjust squelch level. 2. Rotate [DIAL] once and rotate to adjust volume. 3. Activate Vibration function to drain water away from speaker.	10, 14

Express Warranty (Australia)

This Express Warranty is provided by Oricom International Pty Ltd ABN 46 086 116 369, Unit 1, 4 Sovereign Place, South Windsor NSW 2756, herein after referred to as "Oricom".

Oricom products come with guarantees that cannot be excluded under the Australian Consumer Law. You are entitled to a replacement or refund for a major failure and compensation for any other reasonably foreseeable loss or damage. You are also entitled to have the goods repaired or replaced if the goods fail to be of acceptable quality and the failure does not amount to a major failure. Oricom warrants that the product is free from defects in materials or workmanship during the Express Warranty Period. This Express Warranty does not extend to any product from which the serial number has been removed or was purchased outside of Australia.

Nothing in this Express Warranty excludes, restricts or modifies any condition, warranty, guarantee, implied term, right or remedy pursuant to the Australian Consumer Law and which may not be so excluded, restricted or modified. For such conditions, terms, guarantees and warranties that cannot be excluded, restricted or modified, Oricom limits the remedies available to extent permitted in the relevant legislation.

The Express Warranty Period will be 2 years (excluding battery cells and rechargeable battery packs) from the date of purchase of the product evidenced by your dated sales receipt. You are required to provide proof of purchase as a condition of receiving Express Warranty services.

You are entitled to a replacement product or repair of the product at our discretion according to the terms and conditions of this document if your product is found to be faulty within the Express Warranty Period. This Express Warranty extends to the original purchaser only and is not transferable.

Products distributed by Oricom are manufactured using new materials or new and used materials equivalent to new in performance and reliability. Spare parts may be new or equivalent to new. Spare parts are warranted to be free from defects in material or workmanship for thirty (30) days or for the remainder of the Express Warranty Period of the Oricom branded product in which they are installed, whichever is longer. During the Express Warranty Period, Oricom will where possible repair and if not replace the faulty product or part thereof. All component parts removed under this Express Warranty become the property of Oricom. In the unlikely event that your Oricom product has a recurring failure, Oricom may always, subject to the Competition and Consumer Act 2010, at its discretion, elect to provide you with a replacement product of its choosing that is at least equivalent to your product in performance.

No change to the conditions of this Express Warranty is valid unless it is made in writing and signed by an authorised representative of Oricom.

Oricom will not be liable under this Express Warranty, and to the extent permitted

by law will not be liable for any defect, loss, damage or injury arising out of or in connection with a:

1. Failure by you to adhere to the warnings and follow the instructions set out in this user guide for the proper installation and use of the product;
2. Wilful misconduct or deliberate misuse by you of the product;
3. Any external cause beyond our control, including but not limited to power failure, lightning or over voltage; or
4. Modification to the product or services carried out on the product by anyone other than Oricom or Oricom's authorised service provider.

How to make a claim under your Express Warranty in Australia

Oricom has a simple warranty process for you to follow:

- Please call or email our Customer Support Team, 02 4574 8888 or support@oricom.com.au.
- A Customer Support Team member will verify after troubleshooting with you if your product qualifies under warranty. If so, they will give you a Product Return Authorisation number.
- We will then email or fax a Return Authorisation form and a Repair Notice (if necessary), together with instructions on how to return the goods for warranty service.

Please note that if a Customer Support Team member advises that your product does not qualify for return, this warranty does not apply to your product. Products that are authorised to be returned to Oricom in Australia must include all of the following:

- A completed Return Authorisation form
- A copy of your Proof of Purchase (please keep your original copy)
- The faulty product, including all accessories.

Send the approved returns to:

Oricom International Pty Ltd
Locked Bag 658
South Windsor NSW 2756 Australia

Please note that this Express Warranty excludes expenses incurred by you in returning any faulty product to us. You must arrange and pay any expenses incurred (including postage, delivery, freight, transportation or insurance of the product) to return the faulty product to us, however, we will arrange delivery of the repaired or replaced faulty product to you.

Important Information

Repair Notice

Please be aware that the repair of your goods may result in the loss of any user-generated data (such as stored telephone numbers, text messages and contact information). Please ensure that you have made a copy of any data saved on your goods before sending for repair. Please also be aware that goods presented for repair may be replaced by refurbished goods or parts of the same type rather than being repaired.

Contact details for Oricom support and Express warranty claims in Australia

Oricom International Pty Ltd
Locked Bag 658
South Windsor, NSW 2756
Australia

Email: support@oricom.com.au

Phone: (02) 4574 8888

(Monday to Friday 8am to 6pm AEST)

Web: www.oricom.com.au

Fax: (02) 4574 8898

Contact details for Oricom support and Express warranty claims in New Zealand

Email: support@oricom.co.nz

Phone: 0800 674 266

(Monday to Friday 10am to 8pm NZST)





oricom.com.au
