

BAR FRIDGES

Cooling the Beers of a Nation New Zealand

New Zealand's best range of chillers

MODEL:
HUS-SC50AB

QUICK INFO

PARTS AND ENERGY INFO

- 12Volt Fans
- Cyclopentane foaming
- LED lighting
- LOW E glass
- R600 100% ozone safe gas



SPECIFICATIONS

Capacity (litres)	50
Holds (cans)	38
Noise Level	41
Consumption	1.10Kwh/24Hrs
Unit dimensions (WxDxH)	435 x 500 x 510
Lockable	Yes
Gross weight	16 kg

SCHMICK 
Australia

**Specifications and price of this product may change at any time

**For more information about this product please call us or visit our website.

PRODUCT INFORMATION

HUS-SC50AB

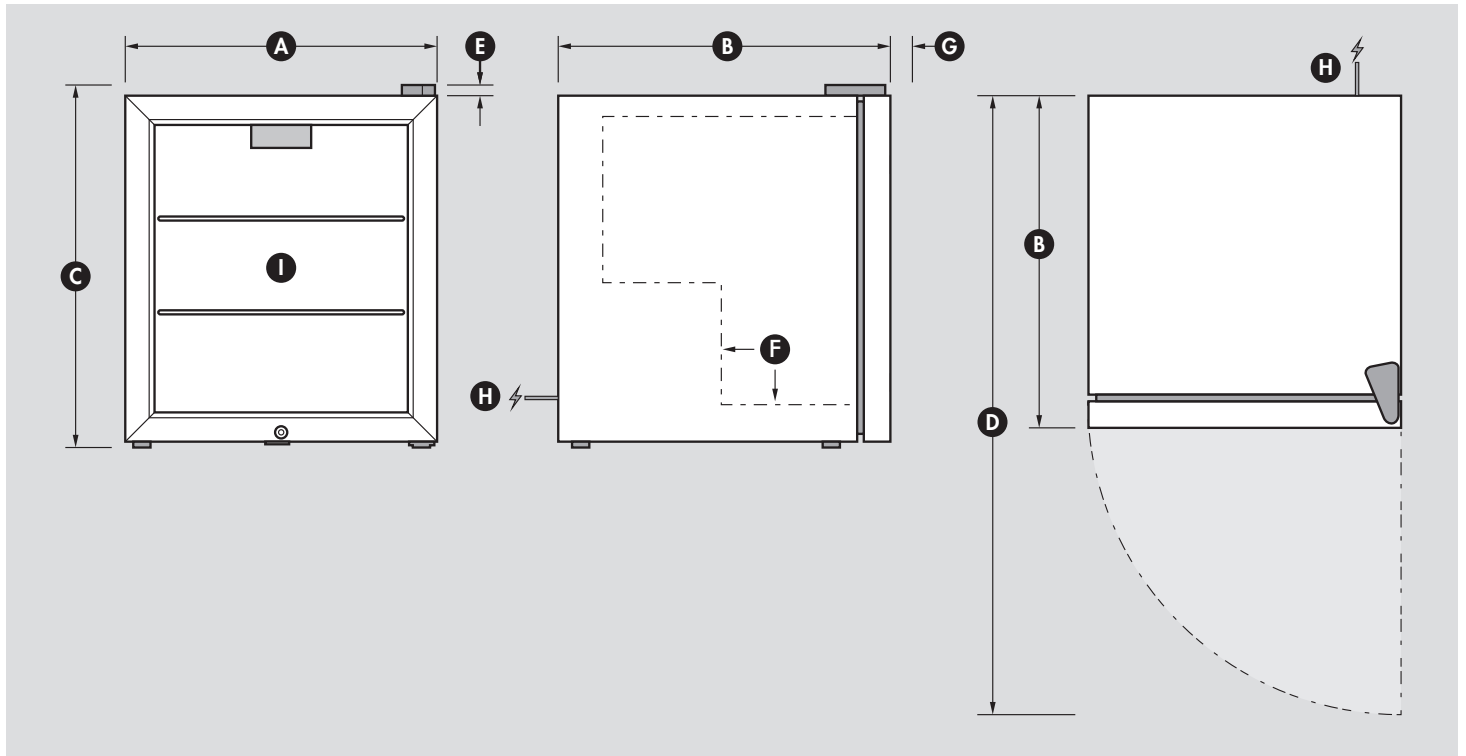

INFORMATION

DIMENSIONS

(A)	Overall width	430mm
(B)	Overall depth	490mm
(C)	Overall height - includes feet	510mm
(D)	Overall depth with door open	890mm
(E)	Height of hinge cap (included in height above)	10mm
(F)	Internal step inside unit	210mm In & 190mm High
(G)	Depth of handle (adds to depth above)	35mm
(H)	Power cord location & length	1800mm
(I)	Internal dimensions (WxDxH)	340 x 380 x 420mmH

Note: Door opens maximum 10mm outside fridge diameter

INSTALLATION & BUILDING INTO CAVITY'S

Minimum cavity size needed (WxDxH) 470 x 530 x 530mmH
 Venting type of fridge REAR - A rear vent would lessen run times.

Note: If wanting a 'cabinet door' in front of fridge door please contact us

OTHER HELPFUL INFORMATION

Height floor to bottom of door	20mm
Door size (WxH)	435 x 480mmH
Feet height fully tightened	15mm
Height adjustment available on current feet	None
Change feet size for extra height option	N/A
Shelf Qty / Size	1 x (345x310mmD) & 1 x (345x205mmD)
Wine Shelf available (Y/N)	Yes

PERFORMANCE

Cooling	Can cool to 0oC (Zero)
Application suitability	Indoor
Maximum operating ambient temperature	32oC
Meps energy approved & food grade	Yes