

ASSEMBLING YOUR SPRAYER RACK



PARTS

- 1 Upright Steel Plate
- 2 Locking Pin & Spacing Jam
- 3 Steel Lid
- 4 M8x1.25 Nuts & Bolts (8)
- 5 Shoulder Bolts & Nuts (2)
- 6 Base Steel Plate

REQUIRED TOOLS

- 1 13 mm Wrench
 - 2 4 mm Allen Key
 - 3 17 mm Wrench
- (Optional: Ratchet or driver 13mm socket)

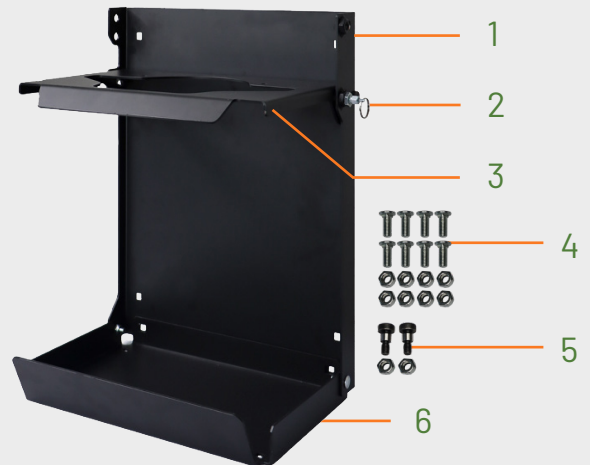

STEP 1:

Align the upright steel plate (1) with the base steel plate (6) of the rack using the square holes as a guide.



STEP 4:

Align the steel lid (3) with the upright steel plate (1) using the round holes as a guide.
Top Position = 4 Gallon
Bottom Position = 2.5 Gallon



STEP 2:

Begin assembling by placing a M8x1.25 bolt (4) in both side square openings, then use your fingers & the 13 mm wrench to secure the nut to the bolt.



STEP 5:

Thread a shoulder nut & bolt (5) into the top hole using a 4 mm Allen key. Repeat on the other side for a secure rotation.



STEP 3:

Place a M8x1.25 (4) bolt through the back of the upright steel plate (1) opening, then use your finger to secure the nut to the bolt. Tighten with a wrench.



STEP 6:

Thread the locking pin (2) and tighten the jam nut using the 17 mm wrench to secure the pin in place (2).