

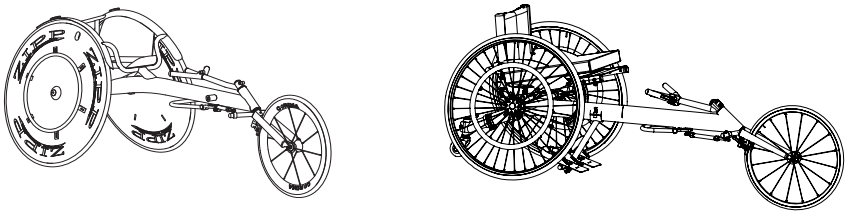

Invacare® Top End® Eliminator™ Racing Chair
 Invacare® Top End® Preliminator™ Racing Chair

EN User Manual



Eliminator Preliminator

*This manual MUST be given to the user of the product.
 BEFORE using this product, read this manual and save for future reference.*



INVACARE
 Yes, you can.

Invacare Corporation www.invacare.com and www.topendchair.com

USA
 One Invacare Way
 Elyria, Ohio USA
 44035
 800-333-6900

Manufactured by:
 Top End Sports and Recreation Products
 4501 63rd Circle North
 Pinellas Park, Florida
 33781-5914
 (727) 522-8677
 (800) 532-8677

Part No 1052767 Rev D-01 12/27/16

Making Life's Experiences Possible®





Yes, you can.

APPROVED ORIGINAL

Carla Locke

12/29/16

This document was released at Pre-Release 01.

NOTES:

1. Page Count: 52 pages
2. Page Formatted For: A5 or 5.5 x 8.5 inches
3. Orientation: Landscape
4. Color: Black and White
5. Special Instructions:

**DO NOT PRINT THIS DRAWING.
 This drawing is for informational purposes only.
 See attached document.**

TITLE: MANUAL, USER TOP END ELIM PRELIM RACING CHAIRS																
PART NUMBER: 1052767	REV: D	SHEET: 1 OF 1														
ALL DIMENSIONS ARE IN INCHES UNLESS OTHERWISE SPECIFIED TOLERANCES (UNLESS OTHERWISE SPECIFIED):																
<table border="0"> <tr> <th style="text-align: center;">INCHES</th> <th style="text-align: center;">METRIC</th> </tr> <tr> <td>DECIMALS: ____ X = N/A</td> <td>X = ± 3mm</td> </tr> <tr> <td>.X = ± .1</td> <td>.X = ± .5mm</td> </tr> <tr> <td>.XX = ± .02</td> <td>.XX = ± .13mm</td> </tr> <tr> <td>.XXX = ± .005</td> <td>.XXX = ± N/A</td> </tr> <tr> <td>FRACTIONS: _____ ± 1/64</td> <td>± 1/64</td> </tr> <tr> <td>ANGLES: _____ ± .5°</td> <td>± .5°</td> </tr> </table>		INCHES	METRIC	DECIMALS: ____ X = N/A	X = ± 3mm	.X = ± .1	.X = ± .5mm	.XX = ± .02	.XX = ± .13mm	.XXX = ± .005	.XXX = ± N/A	FRACTIONS: _____ ± 1/64	± 1/64	ANGLES: _____ ± .5°	± .5°	
INCHES	METRIC															
DECIMALS: ____ X = N/A	X = ± 3mm															
.X = ± .1	.X = ± .5mm															
.XX = ± .02	.XX = ± .13mm															
.XXX = ± .005	.XXX = ± N/A															
FRACTIONS: _____ ± 1/64	± 1/64															
ANGLES: _____ ± .5°	± .5°															
NATIVE FILES CONTROLLED BY INVACARE TECHNICAL WRITING ONLY																

Invacare[®] Top End[®] Eliminator[™] Racing Chair

Invacare[®] Top End[®] Preliminator[™] Racing Chair

EN User Manual

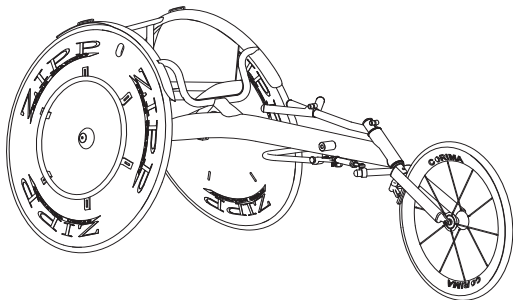

Eliminator

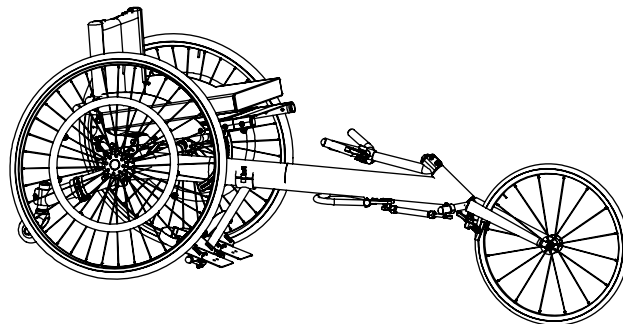

Preliminator

This manual MUST be given to the user of the product.

BEFORE using this product, read this manual and save for future reference.



Yes, you can.[®]

© 2016 Invacare Corporation. All rights reserved. Republication, duplication or modification in whole or in part is prohibited without prior written permission from Invacare. Trademarks are identified by ™ and ®. All trademarks are owned by or licensed to Invacare Corporation or its subsidiaries unless otherwise noted.

Making Life's Experiences Possible is a registered trademark in the U.S.A.

Teflon is a registered trademark of E.I. Du Pont De Nemours and Company.

Loctite is a registered trademark of Loctite Corporation.

User Manual

DEALER: This manual MUST be given to the user of the product.

USER: BEFORE using this product, read this manual and save for future reference.

1	GENERAL	5
	Symbols.....	5
	Dealer/Technician Information.....	5
	Warranty Information.....	6
	European Limited Warranty Information and Customer Service.....	7
2	OVERVIEW	8
	Label Location and Component Identification.....	8
	Specifications.....	10
	Tire Pressure Conversion.....	12
3	SAFETY	13
	General Guidelines.....	13
	Operating Information.....	15
	Transferring Into/Out of the Racing Chair.....	18
	Reaching and Bending Forward, Backward or Sideways.....	20
4	SAFETY INSPECTION/TROUBLESHOOTING	21
	Safety Inspection Checklist.....	21
	Troubleshooting.....	22
	Suggested Maintenance Procedures.....	23
5	INITIAL SETUP	24
	Installing the Rear Wheel.....	24
	Assembling the Preliminators Racing Wheelchair.....	25
6	OPERATION	26
	Operating the Racing Chair.....	26
7	HANDLING	27
	Adjusting the Track Control Steering Mechanism for Straights and Turns.....	27

CONTENTS

8 UPHOLSTERY	28
Adjusting Back Upholstery	28
Adjusting Foot Pouch	30
9 FOOTREST	31
Using Fixed Footrest or Plastic Footplate	31
Adjusting Fixed Footrest.....	31
10 WHEELS	32
Determining Toe In/Toe Out.....	32
Adjusting Toe In/Toe Out.....	33
Replacing Camber Inserts.....	33
11 BRAKES	34
Adjusting Brake Sensitivity	34
Adjusting Brake Pads	35
12 SERVICE PROCEDURES	36
Replacing Back Upholstery.....	36
Replacing Foot Pouch	37
Replacing Seat Sling Upholstery	38
Repairing/Replacing Rear Wheel Tire/Tube.....	39
Replacing Pushrims.....	39
Removing/Installing Front Wheel.....	40
Replacing Brake Pads	40
Removing/Installing the Plastic Footplate.....	41
Replacing or Adjusting the Track Control Steering Mechanism	41
Compensator Cylinder Replacement	42
Assembling a Fork onto the Racing Wheelchair	43
13 OPTIONS	45
Installing Safety Lights	45
Using Safety Helmet.....	45
Installing the Computer	46
Assembling/Adjusting/Using the Bike Rack.....	46
Using the Alignment Gauge.....	48
Additional Options.....	49

I General

I.1 Symbols

Warnings

Signal words are used in this manual and apply to hazards or unsafe practices which could result in personal injury or property damage. See the information below for definitions of the signal words.



DANGER

Danger indicates an imminently hazardous situation which, if not avoided, will result in death or serious injury.



WARNING

Warning indicates a potentially hazardous situation which, if not avoided, could result in death or serious injury.



CAUTION

Caution indicates a potentially hazardous situation which, if not avoided, may result in property damage or minor injury or both.



IMPORTANT

Indicates a hazardous situation that could result in damage to property if it is not avoided.



Gives useful tips, recommendations and information for efficient, trouble-free use.

I.2 Dealer/Technician Information

The term “qualified technician” in this manual refers to an Invacare qualified technician.

I GENERAL

I.3 Warranty Information

United States Limited Warranty

PLEASE NOTE: THE WARRANTY BELOW HAS BEEN DRAFTED TO COMPLY WITH FEDERAL LAW APPLICABLE TO PRODUCTS MANUFACTURED AFTER JULY 4, 1975.

This warranty is extended only to the original purchaser who purchases this product when new and unused from Invacare or a dealer. This warranty is not extended to any other person or entity and is not transferable or assignable to any subsequent purchaser or owner. Coverage under this warranty will end upon any such subsequent sale or other transfer of title to any other person.

This warranty gives you specific legal rights and you may also have other legal rights which vary from state to state.

Invacare warrants the Eliminator and Preliminator frames to be free from defects in materials and workmanship for a period of two years from date of purchase to the original owner or with a copy of the seller's invoice required for coverage under this warranty. All component parts including, but not limited to fork, compensator, and upholstery are warranted against defects in materials and workmanship for a period of one (1) year from the original invoice date except steering cylinders, cushion, bushings, bearings, cables and tires/tubes. Carbon fiber wheels are subject to the wheel manufacturer's warranty and are not warranted by Invacare. If within such warranty period any such product shall be proven to be defective, such product shall be repaired or replaced, at Invacare's option. This warranty does not include any labor or shipping charges incurred in replacement part installation or repair of any such product. Invacare's sole obligation and your exclusive remedy under this warranty shall be limited to such repair and/or replacement.

For warranty service, please contact the dealer from whom you purchased your Invacare product. In the event you do not receive satisfactory warranty service, please write directly to Invacare at the address below. Provide dealer's name, address, date of purchase, indicate nature of the defect and, if the product is serialized, indicate the serial number. Do not return products to our factory without our prior consent.

Limitations and Exclusions: The foregoing warranty shall not apply to serial numbered products if the serial number has been removed or defaced, products subjected to negligence, accident, improper operation, maintenance or storage, commercial or institutional use, products modified without Invacare's express written consent (including, but not limited to, modification through the use of unauthorized parts or attachments; products damaged by reason of repairs made to any component without the specific consent of Invacare, or to a product damaged by circumstances beyond Invacare's control, and such evaluation will be solely determined by Invacare. The warranty shall not apply to problems arising from normal wear, use on an indoor training roller, or failure to adhere to these instructions.

The foregoing warranty is exclusive and in lieu of all other express warranties. Implied warranties, if any, including the implied warranties of merchantability and fitness for a particular purpose, shall not extend beyond the duration of the express warranty provided herein and the remedy for violations of any implied warranty shall be limited to repair or replacement of the defective product pursuant to the terms contained herein. Invacare shall not be liable for any consequential or incidental damages whatsoever.

THIS WARRANTY SHALL BE EXTENDED TO COMPLY WITH STATE/PROVINCIAL LAWS AND REQUIREMENTS.

1.4 European Limited Warranty Information and Customer Service

For more information on Limited Warranty within Europe, please contact the Invacare representative within your country.

Belgium & Luxembourg:

Invacare nv, Autobaan 22, B-8210 Loppem
Tel: (32) (0)50 83 10 10, Fax: (32) (0)50 83 10 11
belgium@invacare.com, www.invacare.be

Danmark:

Invacare A/S, Sdr. Ringvej 37, DK-2605 Brøndby
Tel: (45) (0)36 90 00 00, Fax: (45) (0)36 90 00 01
denmark@invacare.com, www.invacare.dk

Deutschland:

Invacare GmbH, Alemannenstraße 10, D-88316 Isny
Tel: (49) (0)75 62 7 00 0, Fax: (49) (0)75 62 7 00 66
kontakt@invacare.com, www.invacare.de

Eastern Europe, Middle East & CIS:

Invacare EU Export, Kleiststraße 49, D-32457 Porta Westfalica, Germany
Tel: (49) (0)57 31 754 540, Fax: (49) (0)57 31 754 541
webinfo-eu-export@invacare.com, www.invacare-eu-export.com

España:

Invacare SA, c/Areny s/n, Polígon Industrial de Celrà, E-17460 Celrà (Girona)
Tel: (34) (0)972 49 32 00, Fax: (34) (0)972 49 32 20
contactsp@invacare.com, www.invacare.es

France:

Invacare Poirier SAS, Route de St Roch, F-37230 Fondettes
Tel: (33) (0)2 47 62 64 66, Fax: (33) (0)2 47 42 12 24
contactfr@invacare.com, www.invacare.fr

Ireland:

Invacare Ireland Ltd, Unit 5 Seatown Business Campus, Seatown Road, Swords, County Dublin - Ireland
Tel: (353) 1 810 7084, Fax: (353) 1 810 7085
ireland@invacare.com, www.invacare.ie

Italia:

Invacare Mecc San s.r.l., Via dei Pini 62, I-36016 Thiene (VI)
Tel: (39) 0445 38 00 59, Fax: (39) 0445 38 00 34
italia@invacare.com, www.invacare.it

Nederland:

Invacare BV, Galvanistraat 14-3, 6716 AE Ede, NL-6716 BZ Ede
Tel: (31) (0)318 695 757, Fax: (31) (0)318 695 758
nederland@invacare.com, www.invacare.nl, csede@invacare.com

Norge:

Invacare AS, Grensesvingen 9, Postboks 6230, Etterstad, N-0603 Oslo
Tel: (47) (0)22 57 95 00, Fax: (47) (0)22 57 95 01
norway@invacare.com, www.invacare.no
island@invacare.com

Österreich:

Invacare Austria GmbH, Herzog Odilostrasse 101, A-5310 Mondsee
Tel: (43) 6232 5535 0, Fax: (43) 6232 5535 4
info@invacare-austria.com, www.invacare.at

Portugal:

Invacare Lda, Rua Estrada Velha, 949, P-4465-784 Leça do Balio
Tel: (351) (0)225 1059 46/47, Fax: (351) (0)225 1057 39
portugal@invacare.com, www.invacare.pt

Sverige:

Invacare AB, Fagerstagatan 9, S-163 53 Spånga
Tel: (46) (0)8 761 70 90, Fax: (46) (0)8 761 81 08
sweden@invacare.com, www.invacare.se, finland@invacare.com

Suomi:

Camp Mobility, Patamäenkatu 5, 33900 Tampere, Puhelin 09-35076310
Internet www.campmobility.fi, Sähköposti info@campmobility.fi

Switzerland:

Invacare AG, Benkenstrasse 260, CH-4108 Witterswil
Tel: (41) (0)61 487 70 80, Fax: (41) (0)61 487 70 81
switzerland@invacare.com, www.invacare.ch

United Kingdom:

Invacare Limited, Pencoed Technology Park, Pencoed, Bridgend CF35 5AQ
Tel: (44) (0)1656 776222, Fax: (44) (0)1656 776220
UK@invacare.com, www.invacare.co.uk

2 Overview

2.1 Label Location and Component Identification

Eliminator Racing Chair

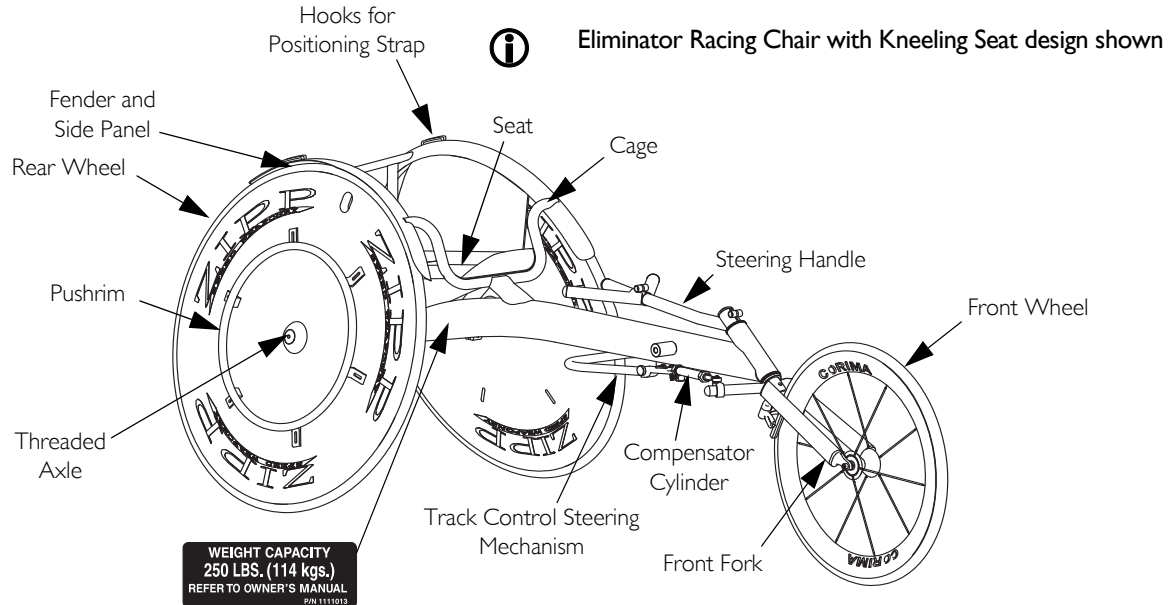

Preliminator Racing Chair

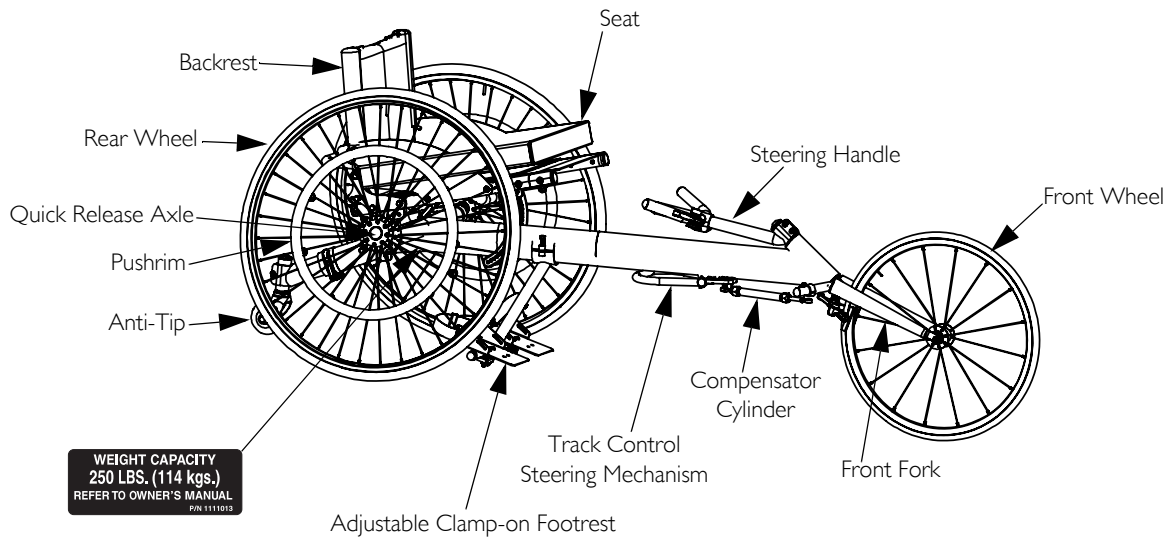

2 OVERVIEW

2.2 Specifications

	Eliminator Racing Chair
Upper Inside Frame Width:	Custom
Seat Style:	Standard or Kneel Position
Cage Style:	I, V, Open V, or U Cage
Lower Inside Seat Width (Seat Cage):	Inside Seat measurement to allow for hip space - snug is preferred
Axle Position (from front of the backrest upright):	5 to 8 inches
Seat Height (height from floor) Rear:	15 - 20 inches
Front:	16 - 20 inches
Overall Length (Front Wheel to Rear Wheel):	68 to 76 inches
Camber:	11, 12, 13 and 15 degrees
Rear Wheel Size (diameter):	700C spoked performance
Rear Axle (diameter):	1/2 - inch threaded
Pushrims (diameter):	Rubber coated - 13 to 16 inches
Front Wheel Size (diameter):	20 inches (carbon fiber optional)
Brake:	Hand Caliper
Weight:	17 lbs
Shipping Weight:	27 lbs
Standard Equipment:	Brake, Positioning Straps (25", 30", 35"), Tool Kit, Pushrims, Front and Rear Wheels and Side Guards
Options: *see order form	Aluminum Knee Plate, Aluminum Seat, Fixed Footrest, Helmet, Cordless Speedometer, Additional Straps, Cushion, Racing Shirt, Wheel Bag, Carbon Fiber Wheel Upgrade, Safety Flag, Safety Lights, Click Straps, Alignment Gauge

	Preliminator Racing Chair
Seat Width:	10, 12, 14, 16 or 18 inches (Stock Model); 10 to 18 inches in 1 inch increments (Custom Model)
Seat Depth:	10, 11, 12, 13, 15 or 17 inches
Seat Style:	Standard
Cage Style:	Adjustable Seat and Back
Axle Position (from front of the backrest upright):	Adjustable 2.75 to 5.75 inches
Seat Height Rear: Front:	Adjustable 13.5 to 15 inch (1/2 inch increments) Adjustable 17 to 21 inches (1/2 inch increments)
Wheelbase:	48 inches (Stock model); 44, 46, 48, 50 and 52 inches (Custom model)
Camber:	12 degrees
Rear Wheel Size (diameter):	26 inch (590) (Stock model); 26 inch (590) or 700C (Custom model)
Rear Axle (diameter):	Quick Release Axle
Pushrims (diameter):	Polyurethane Coated 15 inch diameter (Stock model); 12 to 16 inch diameter in 1/2 inch increments (Custom model)
Front Wheel Size (diameter):	20 inches
Brake:	Hand Caliper
Weight:	24 lbs
Shipping Weight:	45 lbs
Standard Equipment:	Fixed Footrest, 2 in Soft Cushion, Brake, Positioning Straps, Tool Kit, Pushrims, Headset, Front Wheel and Rear Wheels and Side Guards
Options: *see order form	Helmet, Cordless Speedometer, Additional Straps, Racing Shirt, Safety Flag, Click Straps, Alignment Gauge

2 OVERVIEW

2.3 Tire Pressure Conversion



PSI rating is printed on the side of the tire.

Conversion formula: 1 psi = 6.895 kPa (approx. 7 kPa).

PSI	KILOPASCALS	PSI	KILOPASCALS	PSI	KILOPASCALS	PSI	KILOPASCALS
50	345	70	483	90	621	110	758
55	379	75	517	95	655	115	793
60	414	80	552	100	690	120	827
65	448	85	586	105	724		

3 Safety

The safety section contains important information for the safe operation and use of this product.

The Invacare Eliminator and Preliminator racing chairs are custom built to make the most of each athlete's potential by matching up the athlete's ability with the optimum position. The standard position is recommended for athletes who have limited balance and need more of a bucket or squeeze position. The athlete can sit in the traditional position with his/her feet on a footplate. The Preliminator is the ideal choice for beginners. The Eliminator allows for users to use the kneeling position, which is best for experienced athletes with good balance who only kneel in their chair or need an amputee seat.

3.1 General Guidelines



WARNING

Risk of Death, Injury or Damage

Improper use of this product may cause injury or damage.

- If you are unable to understand the warnings, cautions or instructions, contact a healthcare professional or dealer before attempting to use this equipment.

- DO NOT use this product or any available optional equipment without first completely reading and understanding these instructions and any additional instructional material such as user manuals, service manuals or instruction sheets supplied with this product or optional equipment.

Continued use of the wheelchair with damaged parts could lead to the racing chair malfunctioning, causing injury to the user.

- Check all racing chair components and carton for damage and test components before use. In case of damage or if the racing chair is not working properly, contact a qualified technician or Invacare for repair.

A qualified technician MUST perform the initial set up of this wheelchair. Also, a qualified technician must perform all procedures specifically indicated in the manual.

3 SAFETY



WARNING

Risk of Serious Injury or Damage

Use of non-Invacare accessories may result in serious injury or damage.

- Invacare products are specifically designed and manufactured for use in conjunction with Invacare accessories. Accessories designed by other manufacturers have not been tested by Invacare and are not recommended for use with Invacare products.
- DO NOT use non-Invacare accessories.
- To obtain Invacare Top End accessories, contact Invacare Top End by phone at 1-800-532-8677 or at www.invacare.com or www.topendwheelchair.com.



NOTICE

THE INFORMATION CONTAINED IN THIS DOCUMENT IS SUBJECT TO CHANGE WITHOUT NOTICE.

3.2 Operating Information



WARNING

RACING CHAIR USER

As a manufacturer of racing chairs, Invacare endeavors to supply a racing chair to meet many needs of the end user. However, final selection of a racing chair to be used by an individual rests solely with the user and his/her health care professional capable of making such a selection. Use this information only as a basic guide. The techniques that are discussed on the following pages have been used successfully by many.

The user is responsible for normal upkeep and maintenance of the racing chair to keep it in proper operating condition.

Care, consideration and practice **MUST** be taken and observed in the following safety points. Otherwise, injury or damage may occur.

Safe use requires the close attention of the user as well as the assistant. This user manual points out the most common procedures and techniques involved in the safe operation and maintenance of the racing chair. It is important to practice and master these safe techniques until you are comfortable in maneuvering the racing chair.

A helmet **MUST ALWAYS** be worn when operating the racing chair.

TRANSPORT

Invacare recommends that a user is **NOT** transported in vehicles of any kind while in a racing chair. As of this date, the Department of Transportation has not approved any tie-down systems for transportation of a user while in a racing chair, in a moving vehicle of any type.

SERIOUS INJURY CAN OCCUR IN THE EVENT OF A FALL FROM THE PRODUCT

Feet **MUST** be secure. Use hook and loop straps to secure feet before use of the racing chair.

BRAKES

If the brake cable shows signs of wear, the cable **MUST** be replaced or the brake may fail.

ALWAYS check the function of the brake. Be sure that the brakes and all other features of your racing chair are operating properly. Should the primary brake fail, place a gloved hand on a rear wheel to slow the racing chair to a stop.

If necessary, adjust the location of the brake on the steering handle for easy access during use.

NEVER use the brake for immediate stops. Using the brake for immediate stops can make the front wheel lock up (skid) causing the front tire to blow and go flat. If you must stop immediately, grab the rear wheels with **GLOVED** hands.

The brake is designed for managing safe operation of the racing chair at speeds greater than ten miles per hour.



WARNING

Risk of Injury or Damage

The manufacturer is not responsible for failure, damage or injury caused by improper operation or maintenance by the end-user. To determine and establish your particular safety limits, practice transferring activities in the presence of a qualified health care professional before attempting active use of the racing chair.

Operation of the racing chair is subject to all traffic rules and regulations. (This may include the use of a safety lights and reflectors for dusk/night riding.) Give pedestrians the right of way.

Slow down when turning or cornering, otherwise injury or damage may occur.

Use proper hand signals when turning.

Slow down at all street intersections and observe to the right, to the left and back to right again before proceeding.

DO NOT attempt to move up or down an incline with an ice or oil film. Avoid all surface hazards.

DO NOT attempt to ride over curbs or obstacles or speed bumps. Doing so may cause your racing chair to "bottom out" and/or turn over and cause bodily harm or damage to the racing chair.

DO NOT attempt to lift the racing chair by any removable (detachable) parts. Lifting by means of any removable (detachable) parts of an racing chair may result in injury to the user or damage to the racing chair.

DO NOT stand on the seat or frame of the racing chair.

DO NOT carry any riders.

DO NOT carry any items that may obstruct your view or prohibit you from operating the racing chair properly.

Invacare strongly recommends that the racing chair be boxed or otherwise protected before transporting by an airline carrier.

WEIGHT LIMITATION

The Invacare Eliminator Racing Chair has a weight limitation of 250 lbs (114 kg).

The Invacare Preliminator Racing Chair has a weight limitation of 250 lbs (114 kg).



DANGER

Risk of Injury, Damage or Death

Overinflation of tires may cause tires to explode.

- Inflate tire to the proper tire pressure (P.S.I. / kilo pascals) listed on the side wall of the tire.
- Only use the racing chair with the tires at the proper pressure.
- The wheels and tires should be checked periodically for cracks and wear and should be replaced if necessary.



WARNING

Risk of Injury or Damage

TIRE PRESSURE

DO NOT ride on a flat or under inflated tires. Riding on flat or underinflated tires can cause injury, as well as, damage to the tire, tube and racing chair wheels.

CARBON FIBER WHEELS ONLY (Eliminator Only) - Carbon Fiber Wheels MUST NOT be used when tires are bare or flat. If a flat wheel occurs, STOP IMMEDIATELY.

STABILITY AND BALANCE

For stability and proper operation of your racing chair, you MUST at all times maintain proper balance. Turning and cornering affects the stability and balance of the racing chair and user. Your racing chair should remain upright and stable during turns and cornering when operated correctly.

Invacare recommends using positioning strap for additional safety.

A NOTE TO ASSISTANTS

When learning assistance techniques for the racing chair, have an experienced assistant help you before attempting it alone.

When you are assisting with a transfer to/from the racing chair, remember to use good body mechanics. Keep your back straight and bend your knees when lifting or positioning the racing chair for the end-user.

Also, be aware of detachable parts. These must NEVER be used for lifting supports or to move the racing chair, as they may be inadvertently released, resulting in possible injury to the user and/or assistant.

PERCENTAGE OF WEIGHT DISTRIBUTION

The tautness of the back upholstery, knee and/or foot position, as well as the user condition directly relate to the stability of the racing chair. Any change to one or any combination of the three may cause the racing chair to decrease in stability. Turning and cornering will cause a change to the normal balance, the center of gravity, and the weight distribution of the racing chair. To determine and establish your particular safety limits, practice transferring activities in several combinations in the presence of a qualified health care professional before attempting a transfer alone.

Proper positioning is essential for your safety.

3 SAFETY

3.3 Transferring Into/Out of the Racing Chair



WARNING

Before attempting to transfer in or out of the racing chair, every precaution should be taken to reduce the gap distance. Position the racing chair on level ground and as close as possible to the object you are transferring into or out of.

The tautness of the back upholstery, knee and/or foot position, as well as the user condition directly relate to the stability of the racing chair. Any change to one or any combination of the three may cause the racing chair to decrease in stability.

The object you are transferring into or out of **MUST** also be secured before attempting any transfer.

KNEELING SEAT UPHOLSTERY

Ensure that feet slide evenly into the foot pouch and avoid the rear wheel spokes. Ensure that the foot pouch is securely latched to the back upholstery. Otherwise, injury can occur.



Invacare strongly recommends an experienced assistant help in the transferring to and from the racing chair. The assistant should hold down the front of the racing chair to avoid any instability that may occur.

Some racers will rest on the frame cage of the racing chair half way through the transfer and move the **RIGHT** hand to the right side of the frame.

- I. Perform one of the following:
 - A. Kneeling Upholstery Transfer
 - i. Position the chair as close as possible along side the seat to which you are transferring.
 - ii. Shift body weight to the edge of the wheelchair upholstery closest to the racing chair.
 - iii. Place LEFT leg on top of the LEFT cage frame.
 - iv. Start RIGHT leg into the kneeling upholstery and UNDER the seat sling.
 - v. Start LEFT leg into the kneeling upholstery and UNDER the seat sling.
 - vi. Place LEFT hand on the frame cage.
 - vii. Place RIGHT hand on the racing chair frame.
 - viii. Lift and shift weight into racing chair upholstery.
 - ix. Tighten straps at the top of the fender.
 - A. Standard Upholstery Transfer
 - i. Position the chair as close as possible along side the seat to which you are transferring.
 - ii. Shift body weight to the edge of the racing chair upholstery closest to the racing chair.
 - iii. Place LEFT leg through the opening in the frame cage.
 - iv. Place LEFT hand on the frame cage.
 - v. Place RIGHT hand on the wheelchair frame.
 - vi. Lift and shift weight into the racing chair upholstery.
 - vii. Strap feet onto the footplate.
 - viii. Strap the knees up into a safe and comfortable position.
 - ix. Tighten straps at the top of the fender.

Kneeling Upholstery Transfer

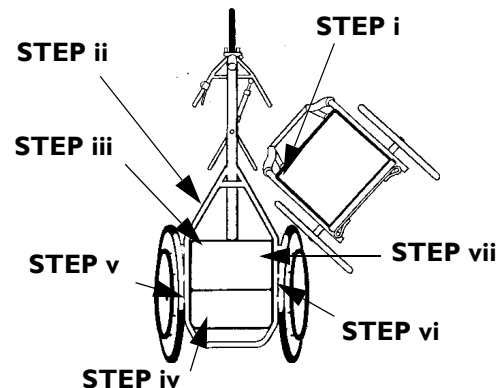

Standard Upholstery Transfer



Once seated in the racing chair, move your feet back as close as possible to the axle as you feel comfortable and tighten the knee strap.

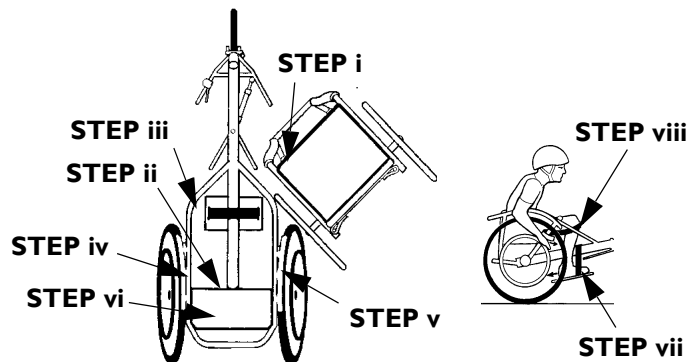

3 SAFETY

3.4 Reaching and Bending Forward, Backward or Sideways



WARNING

DO NOT sit erect or lean over the top of the back upholstery. This will change your center of gravity and may cause you to tip over.

Position the racing chair as close as possible to the desired object. Reach back only as far as your arm will extend without changing your sitting position.

DO THIS

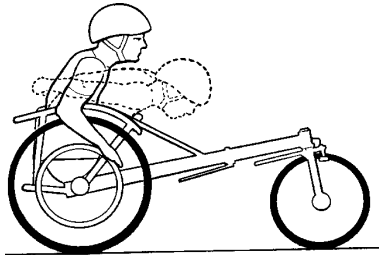

NOT THIS

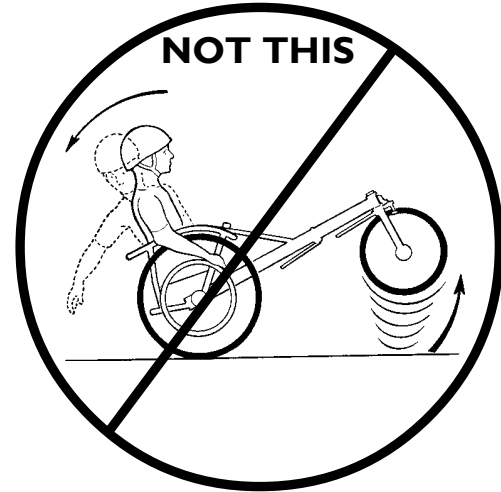

4 Safety Inspection/Troubleshooting



Every six months or as necessary, take your Top End racing chair to a qualified technician for a thorough inspection and servicing. Regular cleaning will reveal loose or worn parts and enhance the smooth operation of your racing chair. For safe and proper operation, your racing chair **MUST** be cared for just like any other vehicle. Routine maintenance will extend the life and efficiency of your racing chair.

4.1 Safety Inspection Checklist

Initial adjustments should be made to suit your personal body structure and preference. Thereafter follow these maintenance procedures:

Inspect/Adjust Initially and Weekly

- Make sure that the racing chair rolls straight (no excessive drag or pull to one side).
- Inspect seat and back upholstery for rips or sagging.
- Inspect that rear wheel axles are securely tightened.
- Inspect that there is no excessive side movement or binding when rear wheel is lifted and spun.
- Inspect pushrims for signs of peeling of coating where it might separate from the pushrim.
- Inspect spokes for bent or broken spokes.
- Inspect that all spokes are uniformly tight.
- Inspect front wheel/fork assembly for proper tension by front wheel; front wheel should come to a gradual stop. Loosen/tighten allen screws if wheel wobbles noticeably or binds to a stop. There will be some play in the front wheel.
- Inspect that the wheel bearings are clean and free of moisture.
- Inspect that the brake does not interfere with front wheel when rolling.
- Inspect that the brake is easy to engage.
- Inspect that there is no excessive wear of brake pads.



CAUTION

As with any vehicle, the wheels and tires should be checked periodically for cracks, flat spots and wear, and should be replaced.

- Inspect tires for flat spots and wear.
- Check pneumatic tires for proper inflation.
- Check frame cage for interference with tires.
- Clean upholstery with light detergent and water.
- Inspect for bent or broken frame.

4 SAFETY INSPECTION/TROUBLESHOOTING

- If installed, inspect the fixed footrest mounting hardware to ensure it is tight and the footrest secure.
- Inspect footrest straps for wetness and/or damage.
- Inspect seat positioning straps for any signs of wear. Replace if necessary.

Inspect/Adjust Monthly

- Inspect that rear wheel axles are securely tightened.
- Inspect front wheel/fork assembly for proper tension by front wheel; front wheel should come to a gradual stop. Loosen/tighten allen screws if wheel wobbles noticeably or binds to a stop. There will be some play in the front wheel.
- Inspect that the wheel bearings are clean and free of moisture.
- Inspect that the brake does not interfere with front wheel when rolling.
- Inspect that there is no excessive wear of brake pads.

Inspect/Adjust Periodically

- Make sure that the racing chair rolls straight (no excessive drag or pull to one side).
- Inspect upholstery for rips or sagging.
- Inspect that rear wheel axles are securely tightened.
- Inspect that there is no excessive side movement or binding when rear wheel is lifted and spun.
- Inspect pushrims for signs of rough edges or peeling of tire/tape coating where it might separate from the pushrim.
- Inspect that the wheel bearings are clean and free of moisture.
- Inspect that the brake is easy to engage.
- Clean upholstery with light detergent and water.

4.2 Troubleshooting

Veers Right	Veers Left	Sluggish Turn or Performance	Squeaks and Rattles	Looseness in Chair	Solutions
X	X	X			Check tires for correct and equal pressure
X	X				Check for loose stem nuts
			X	X	Check spokes and nipples
		X	X	X	Adjust track control steering mechanism
		X		X	Check toe in/toe out

4.3 Suggested Maintenance Procedures



WARNING

After any adjustments, repair or service and before use, make sure all attaching hardware is tightened securely. Otherwise injury or damage may result.

DO NOT overtighten hardware attaching to the frame. This could cause damage to the frame tubing.

1. Before using your Invacare Top End Eliminator or Preliminator, check all parts for damage or wear and replace, if necessary. Check all parts for proper adjustment.
2. Keep axles free of dirt and lint to ensure proper fit in axle receiver. Cross threading will damage the axles and axle receivers on the Eliminator.
3. Check tires for proper pressure and if not inflated properly, inflate to recommended tire pressure listed on the side wall of the tire.
4. The wheels and tires should be checked periodically for cracks and wear, and should be replaced by a qualified technician.
5. Regularly check for loose spokes in the rear and front wheels. If loose, have them adjusted by a qualified technician.
6. Periodically check pushrims to ensure they are secured to the rear wheels.
7. Periodically adjust brake in correlation to brake pad wear.
8. Periodically check rear and front wheel bearings to make sure they are clean and free from moisture. Use a Teflon[®] lubricant if necessary.
9. Check upholstery for sagging, rips or tears.

5 Initial Setup



WARNING

After any adjustments, repair or service and before use, make sure all attaching hardware is tightened securely. Otherwise injury or damage may occur.

5.1 Installing the Rear Wheel



This procedure applies to Eliminator racing chairs only. There is a RIGHT and LEFT rear wheel. The pushrims should be pushing into the spokes at the top of the rear wheel.

1. Determine the right and left rear wheel.
2. Apply a small amount of grease onto the axle.
3. Let some air out of the tire so it will fit under the fender.
4. Insert the axle into the axle tube on the racing chair frame and guide rear wheel under fender.
5. Securely tighten the axle to the racing chair frame using the allen wrench. If the axle does not thread smoothly, DO NOT force. Line up and try to thread again.

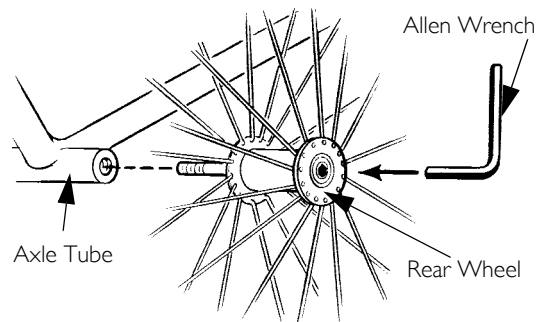

5.2 Assembling the Preliminator Racing Wheelchair

1. Push in the tip of the quick release axle (Detail A).
2. Insert the axle into the racing chair frame.
3. Ensure the anti-tip wheel is positioned properly, about a finger's width above ground. If necessary, adjust the anti-tip wheel by performing the following steps (Detail B):
 - A. Release and loosen the quick release lever attached to the anti-tip clamp.
 - B. Adjust the anti-tip to the desired location.
 - C. Tighten the quick release lever to secure the anti-tip.



WARNING

Pull on the rear wheel to make sure the detent pin and locking pins of the quick-release axle are fully released before operating the racing. Keep locking pins clean.

Detail A - Installing the Rear Wheels

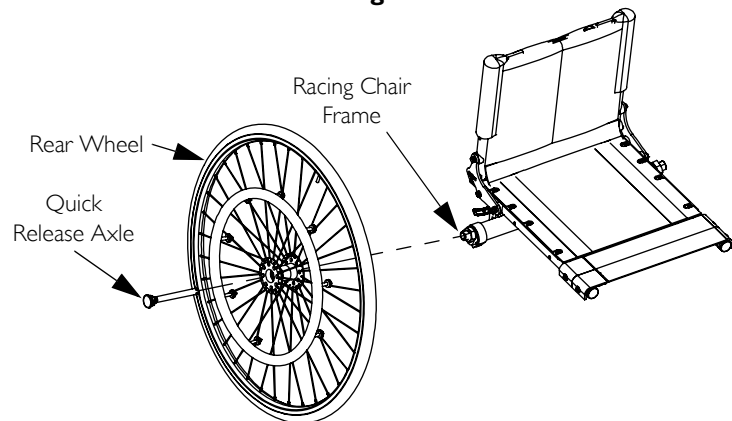

Detail B - Adjusting the Anti-tip

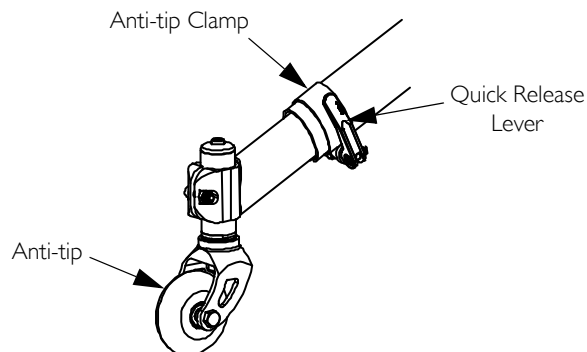

6 Operation



WARNING

Before using your Invacare Top End Eliminator or Preliminator, check all parts for damage or wear and replace, if necessary. Check all parts for proper adjustment.

After any adjustments, repair or service and before use, make sure all attaching hardware is tightened securely. Otherwise injury or damage may occur.

Before operating the racing chair, review the [General Guidelines](#) on page 13 in this user manual.

6.1 Operating the Racing Chair

1. Transfer into the racing wheelchair.
2. Check and adjust the upholstery if necessary.



WARNING

If the racing chair is equipped with kneeling upholstery, always ensure the foot pouch is securely latched to the back upholstery. Otherwise, injury may occur.

3. Check Brakes.
 - Check cable for signs of wear or fraying.
 - Squeeze the brake lever firmly and check for proper brake function.
 - Adjust for pad wear if necessary.
 - Check pads for wear and replace if necessary.
4. Secure feet on the fixed footrest (if installed), on the plastic foot plate or if sitting in the kneel only position, within the foot pouch which is part of the kneeling upholstery.
5. Place at least one hand on the pushrim(s). Rotate the pushrim forward (toward the front) to propel the racing chair forward.

7 Handling



WARNING

After any adjustments, repair or service and before use, make sure all attaching hardware is tightened securely. Otherwise injury or damage may occur.

7.1 Adjusting the Track Control Steering Mechanism for Straights and Turns



The procedures in this section apply to a counter-clockwise race track. Reverse the right and left instructions for a clockwise race track. Different speeds and conditions will affect the way the racing chair handles. Extreme crosswinds should be taken into consideration. Adjustments to the track control steering mechanism should be made while sitting in the racing chair.

To prevent disqualification it is critical that the track control steering mechanism be set to control the chair within the assigned lane and at the speed you intend to race at.

Straights

1. Turn front wheel until it is approximately in a straight line.
2. Turn the right track stop screw until the locknut on the track stop is touching the racing chair frame.
3. Repeat STEPS 1-2 until the racing chair follows a straight line.

Turns

1. Turn front wheel until in required position for turn.
2. Turn the left track stop screw until it is touching the racing chair frame.
3. Repeat STEPS 1-2 until racing chair follows the desired turn.

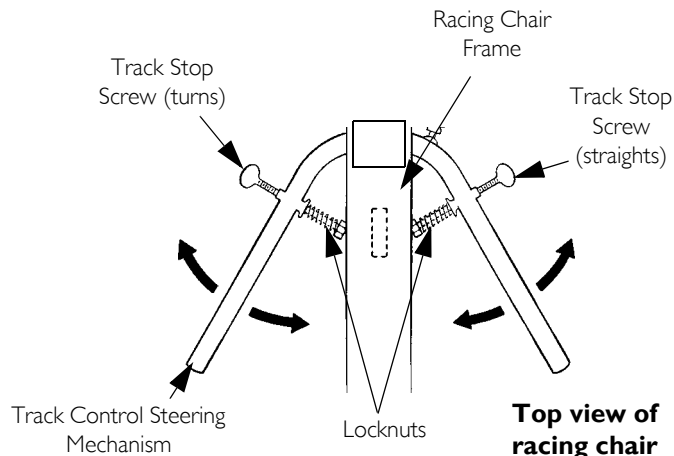

8 Upholstery



WARNING

After any adjustments, repair or service and before use, make sure all attaching hardware is tightened securely. Otherwise injury or damage may occur.

If the racing chair is equipped with kneeling upholstery, always ensure the foot pouch is securely latched to the back upholstery. Otherwise, injury may occur.

8.1 Adjusting Back Upholstery

Eliminator Racing Chairs

1. Unlatch the fastening flaps that secure the back upholstery to the racing chair frame.
2. Adjust the back upholstery to the desired tautness.
 - **TIGHTER** - upholstery will increase the stability and maintain normal maneuverability of the racing chair because the user is pushed forward in the racing chair slightly.
 - **LOOSER** - upholstery will increase the maneuverability and make the racing chair less stable because additional weight is being distributed onto the rear wheels.

Prelimator Racing Chairs



WARNING

Risk of Injury or Damage

- Push pin MUST be protruding through hole in back post.
- Ensure that both back post inserts are at the same height BEFORE assembling the wheelchair.



Before unlatching the fastening flaps, observe the tautness of the back upholstery for installation.

1. Unlatch the two fastening flaps that secure the top of the back upholstery to the back posts and remove from the back posts.
2. Press the push pin on the back post insert tube in and adjust the back height to one of four heights depending on original back height according to the table.



There is a 1-inch (2.54 cm) adjustment pin on the back post insert tube. To raise back to maximum height, first make adjustment to the back post inserts.

3. Reinstall the fastening flaps onto the back posts.



The padded portion of the flap should be oriented forward when installed properly.

Right and left is determined by sitting in the wheelchair.

4. Adjust the new back upholstery to the desired tautness.

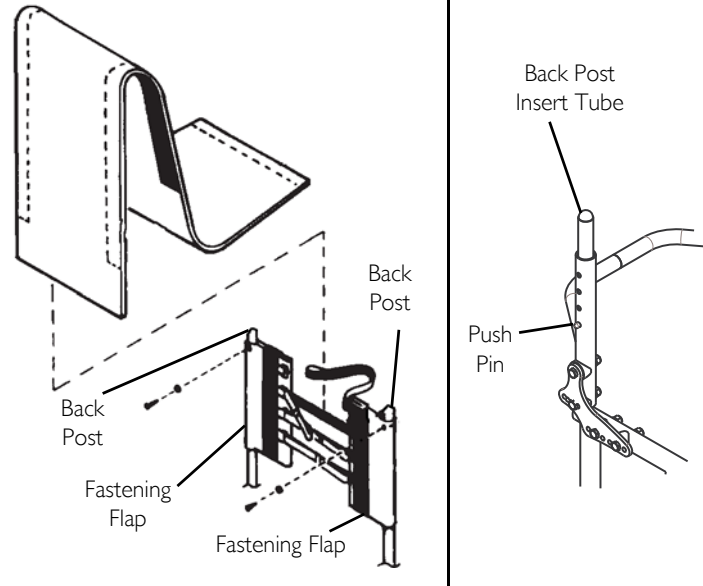

8 UPHOLSTERY

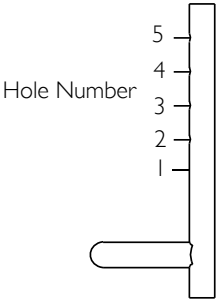
BACK HEIGHT (INCHES)	9-11 INCHES (22.86 - 27.94 CM)	10-14 INCHES (25.40 - 35.56 CM)	12-16 INCHES (30.48 - 40.64 CM)	14-18 INCHES (35.56-45.72 CM)	
HOLE NUMBER*					
	1	9 (22.86 cm)	10 (25.40 cm)	12 (30.48 cm)	14 (35.56 cm)
	2	10 (25.40 cm)	11 (27.94 cm)	13 (33.02 cm)	15 (38.10 cm)
	3	11 (27.94 cm)	12 (30.48 cm)	14 (35.56 cm)	16 (40.64 cm)
	4	N/A	13 (33.02 cm)	15 (38.10 cm)	17 (43.18 cm)
	5	N/A	14 (35.56 cm)	16 (40.64 cm)	18 (45.72 cm)



*Holes numbered from bottom to top for reference only (there are no numbers on the back posts).

8.2 Adjusting Foot Pouch



This procedure applies to Eliminator racing chairs only.

1. Unlatch the fastening flap.
2. Adjust the foot pouch to the desired fit of the user.

9 Footrest



WARNING

After any adjustments, repair or service and before use, make sure all attaching hardware is tightened securely. Otherwise injury or damage may occur.

Feet **MUST** be secured into the fixed footrest **BEFORE** using racing chair. Otherwise injury or damage may occur.

9.1 Using Fixed Footrest or Plastic Footplate

1. Place feet onto footrests or plastic footplate. Secure with foot strap (Detail A).
2. Secure heels with heel strap at the rear of the footplate.

9.2 Adjusting Fixed Footrest

Height

1. Loosen the socket screw on footrest support tube (Detail B).
2. Reposition the footrest support tube up or down as desired.
3. Tighten the socket screw to secure the footrest support tube.

Angle

1. Loosen the locknuts securing the footrest mounting bracket (Detail B).
2. Adjust the angle of the footrest as desired.
3. Tighten the locknuts securing the footrest mounting bracket.

Depth

1. Remove the locknuts (Detail B) and hex screws (Detail A) securing the footrest mounting bracket.
2. Position the footrest to the desired set of mounting holes (Detail A).
3. Install the hex screws through the footrest and footrest mounting bracket.
4. Secure the hex screws with the locknuts. Tighten securely.

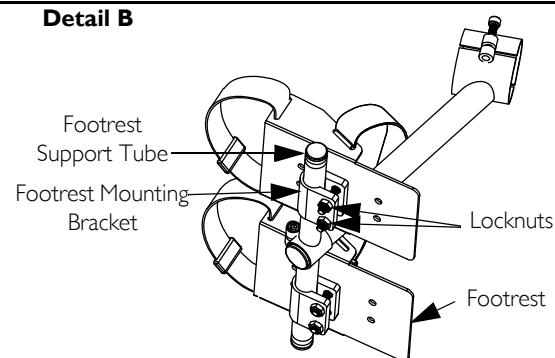
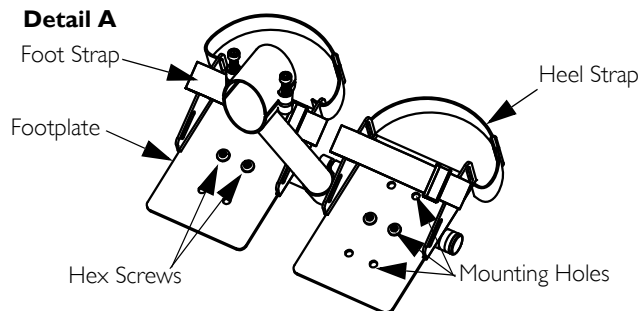

10 Wheels



WARNING

After any adjustments, repair or service and before use, make sure all attaching hardware is tightened securely. Otherwise injury or damage may occur.

10.1 Determining Toe In/Toe Out

1. Inflate all pneumatic tires to recommended tire pressures (listed on the sidewall of the tire).
2. Measure the distance between the center lines at the rear and front of the rear wheels at approximately 12 inches from the ground/floor.



For optimum accuracy, perform STEP 2 with the racing chair occupied.

STEP 2 may be performed with using alignment gauge (available as an option for the racing chair).

3. Determine the difference between the two measurements. If the difference between the two measurements is greater than 1/4-inch ($0 \pm 1/8$ inch for maximum rollability), one of two conditions exists:
 - If the rear centerline measurement of the rear wheels is **SMALLER** than the front centerline measurement of the rear wheels, a toe-out condition exists.
 - If the rear centerline measurement of the rear wheels is **LARGER** than the front centerline measurement of the rear wheels, a toe-in condition exists.
4. If the difference between the measurements is greater than 1/8-inch, correct the toe-in/toe-out condition.

Front of racing chair

Toe-out

Toe-in

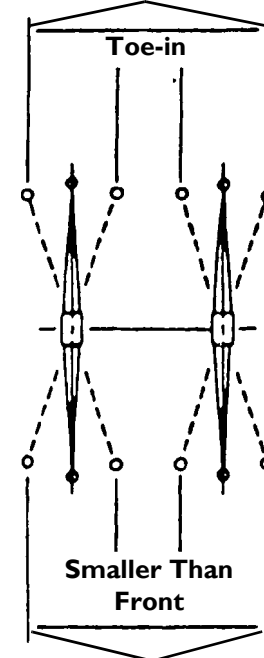

Top View of
racing chair

Larger Than Front

10.2 Adjusting Toe In/Toe Out

1. Loosen, but do not remove the socket screws and clamps that secure camber inserts to the camber bar.
2. Slowly rotate each camber insert equally until the rear wheels are approximately in a straight line.
3. Securely tighten the socket screws and clamps that secure the camber inserts to the camber bar.
4. Measure the distance between the center lines at the rear and front of the rear wheels at approximately 12 inches from the ground/floor.
5. Repeat STEPS 1-4 until the toe in/toe out measurement is less than 1/8-inch (for maximum rollability).

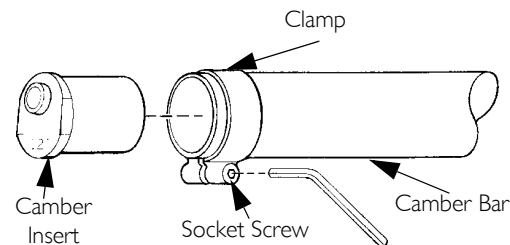

10.3 Replacing Camber Inserts

1. Loosen, but do not remove the socket screws and clamps that secure the camber inserts to the camber bar.
2. Remove the existing camber insert from the camber bar.
3. Install the new camber insert into the camber bar.
4. Adjust the toe in/toe out of the racing chair. Refer to [Adjusting Toe In/Toe Out](#) on page 33.

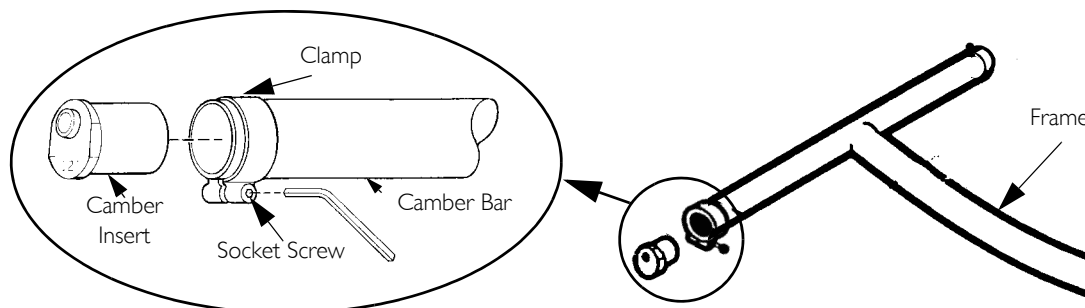

11 Brakes



WARNING

After any adjustments, repair or service and before use, make sure all attaching hardware is tightened securely. Otherwise injury or damage may occur.

11.1 Adjusting Brake Sensitivity



WARNING

Before using the racing chair, inspect the brake and brake pads for proper operation and wear. Replace if worn.

1. Loosen the allen screw that maintains the tautness of the brake cable.
2. Squeeze both brake pads with your hand to adjust the brake cable.
3. Loosely tighten the allen screw to ensure that the brake is adjusted properly.



When the brake is engaged, the brake pads should rest solely on the rim of the wheel. If not, adjust the brake pads.

4. Repeat this procedure until the brake is adjusted properly.
5. Securely tighten the allen screw that maintains the tautness of the brake cable.

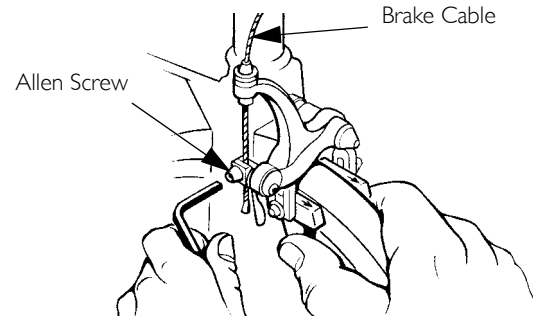

11.2 Adjusting Brake Pads



WARNING

Before using the racing chair, inspect the brake and brake pads for proper operation and wear. Replace if worn.

1. Loosen the allen screw that secures the brake pad to the brake.
2. Position the brake pad until it is in-line with the rim of the front wheel.
3. Securely tighten the allen screw that secures the brake pad to the brake.
4. Repeat this procedure for the opposite side.
5. Adjust the brake.

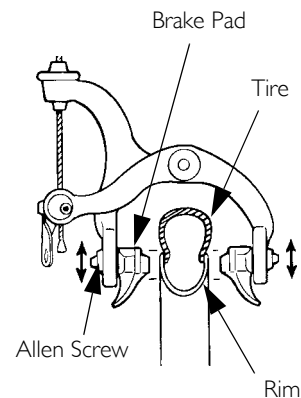

12 Service Procedures

12.1 Replacing Back Upholstery

i This procedure applies to Eliminator racing chairs only.

1. Unlatch the fastening flaps that secure the back upholstery to the racing chair frame.
2. Unlatch the foot pouch of the leg cushion from the back upholstery (kneeling upholstery only).
3. Unlatch the bottom of the back upholstery from the seat sling upholstery.
4. Remove the existing back upholstery from the racing chair.
5. Feed the top two fastening flaps of the new back upholstery through the slots on the racing chair frame.
6. Feed the bottom fastening flap of the new back upholstery between the racing chair frame and the clothing guards.
7. Adjust the back upholstery to the desired tautness.
8. If the racing chair is equipped with kneeling upholstery, attach the foot pouch to the back upholstery and adjust.
9. Adjust the back upholstery to the desired tautness.
 - **TIGHTER** - upholstery will increase the stability and maintain normal maneuverability of the racing chair because the user is pushed forward in the racing chair slightly.
 - **LOOSER** - upholstery will increase the maneuverability and make the racing chair less stable because additional weight is being distributed onto the rear wheels.

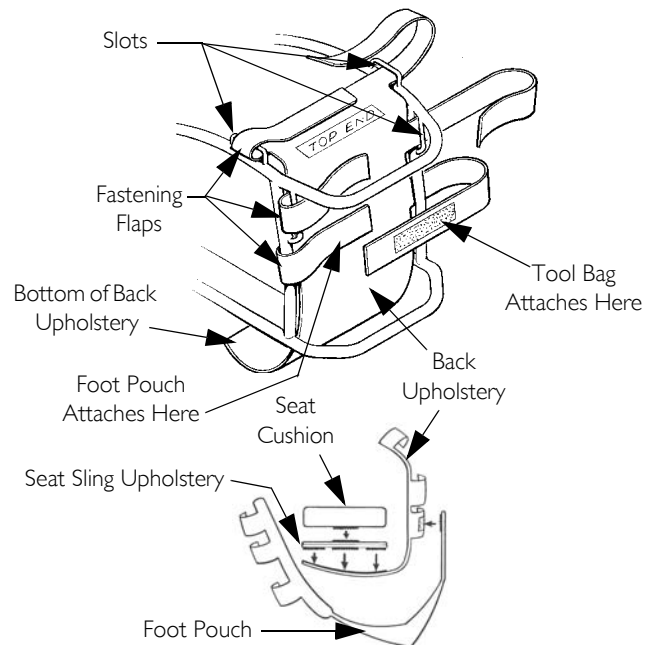

12.2 Replacing Foot Pouch



WARNING

If the racing chair is equipped with kneeling upholstery, always ensure the foot pouch is securely latched to the back upholstery. Otherwise, injury may occur.



This procedure applies to Eliminator racing chairs only.

1. Unlatch the fastening flaps.
2. Unlatch the foot pouch from the back upholstery and remove the foot pouch.
3. Feed the top two fastening flaps between the side guard and racing chair frame and secure together.
4. Adjust the foot pouch to the desired tautness.

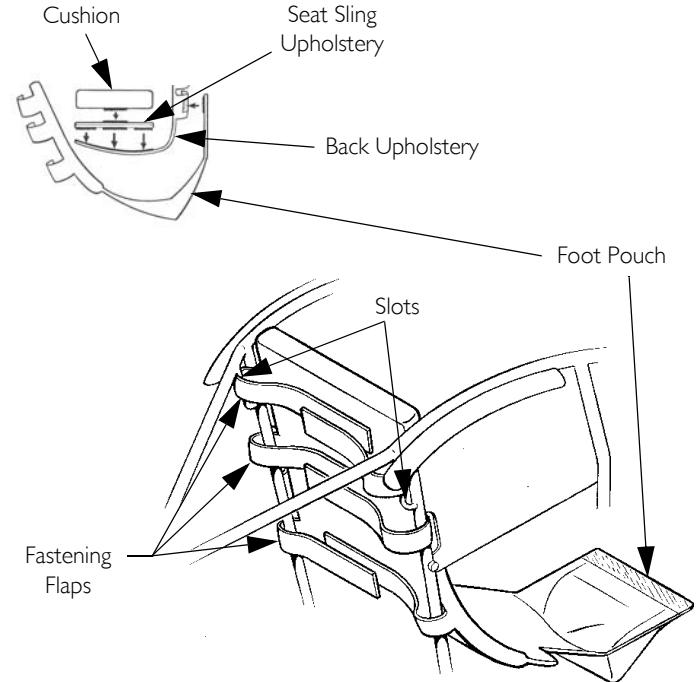

12 SERVICE PROCEDURES

12.3 Replacing Seat Sling Upholstery



This procedure applies to Eliminator racing chairs only.

1. Remove seat cushion from seat sling upholstery.
2. Unlatch the fastening flap that secures the existing seat upholstery to itself.
3. Slide the ends of the existing seat upholstery up and through the frame of the racing chair.
4. Slide the new upholstery through the frame of the racing chair.
5. Pull the seat upholstery to the desired tautness and secure with the fastening flap.
6. Reverse STEPS 1-5 to reassemble.

Racing Chair Frame

Seat Upholstery

Fastening Flap

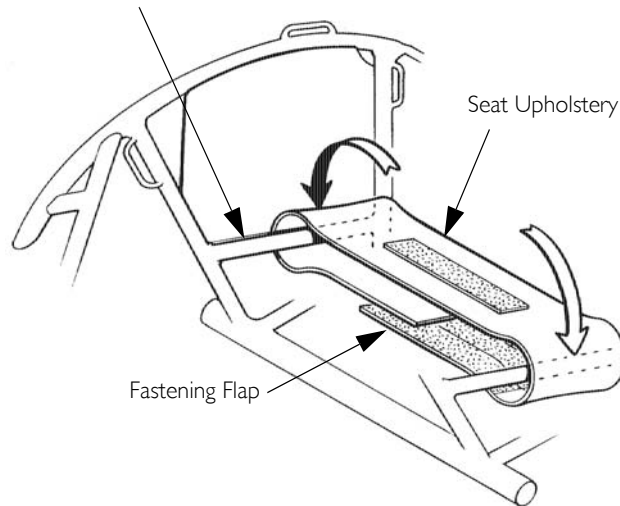

12.4 Repairing/Replacing Rear Wheel Tire/Tube



WARNING

Replacement of a clincher tire or tube **MUST** be performed by a qualified technician.



Tubular tires are tires with tubes sewn into the tires. They are high pressure (140+ lbs. psi) and **MUST** be glued to the rim. Once they have a hole in them, they **MUST** be replaced. Tubular tires will lose air overnight, but they are not faulty. This is a characteristic of tubular tires. Tubular tires **DO NOT** fit on a clincher rim.

Clincher tires are not like conventional bicycle tires. There is an inner tube separate from the actual tire. They are more durable for longer periods of time and if punctured, the tube can be replaced (by a qualified technician). Clincher tires use 100+ lbs. psi. Clincher tires **DO NOT** fit on a tubular rim.

12.5 Replacing Pushrims

1. Remove the rear wheel from the racing chair.
2. Loosen the allen screws that secure the existing pushrim to the rear wheel.
3. Remove the existing pushrim.
4. Install the new pushrim onto the rear wheel and securely tighten the allen screws.



Ensure the rim is pushing onto the spokes at the top of the rear wheel.

5. Reinstall rear wheel onto the racing chair.

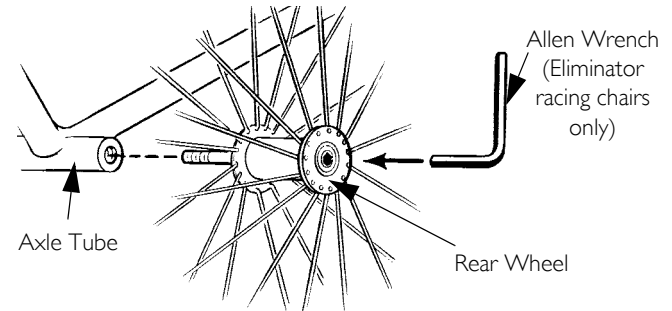

Front of Racing Chair

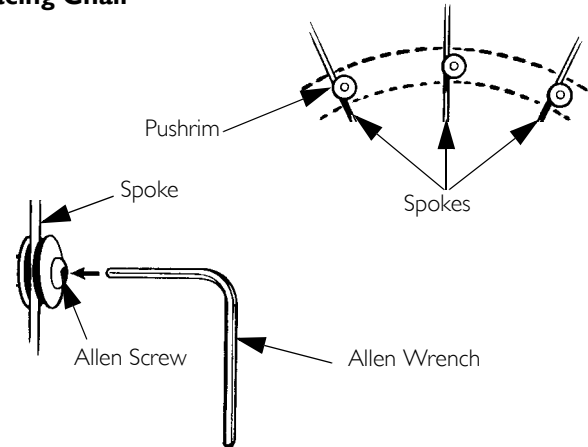

12 SERVICE PROCEDURES

12.6 Removing/Installing Front Wheel



Reverse the steps below to remove the front wheel.

There will be some play in the front wheel. This is common in all front hubs.

1. Remove the two hex axles from the front wheel.
2. Line up the mounting holes in the front wheel with the holes in the forks.
3. Install the hex axles and securely tighten the front wheel to the fork.

12.7 Replacing Brake Pads



WARNING

Before using the racing chair, inspect the brake and brake pads for proper operation and wear. Replace if worn.



Invacare Top End recommends replacing **BOTH** brake pads at the same time to achieve the best brake performance as possible.

1. Remove the front wheel.
2. Remove the screws and washers that secure the existing brake pads to the brake.
3. Install the new brake pad with the arrow pointing towards the front of the racing chair with the existing hardware.
4. Repeat this procedure for the opposite brake pad.
5. Install the front wheel onto the racing chair.
6. Adjust the brake pads as necessary.

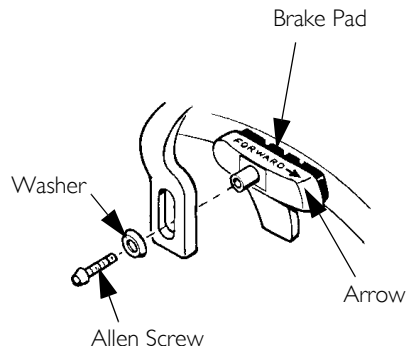
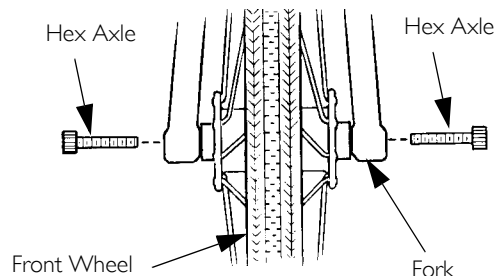

12.8 Removing/Installing the Plastic Footplate

i This procedure applies to Eliminator racing chairs only.

- I. Perform one of the following:
 - To remove, loosen the fastening strap and remove the footplate.
 - To install, secure the fastening straps around the frame.

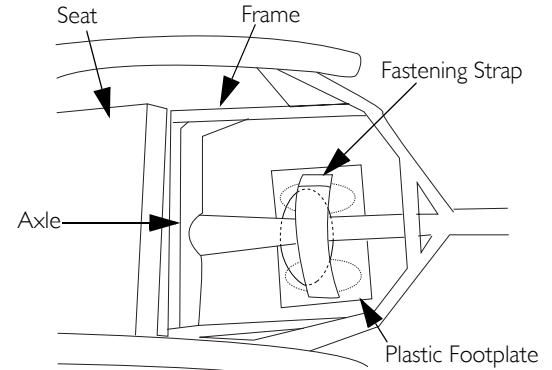

12.9 Replacing or Adjusting the Track Control Steering Mechanism

- Replacing
 - A. Make sure that the leather spacer is in place on the bolt (picture A). If not, order a replacement leather spacer.
 - B. Put the track control steering mechanism on the bolt (picture B).

i The bolt in the fork should never be tightened otherwise the Loctite seal will be broken.

- C. Place the nut over bolt and tighten securely (picture C).
- Adjusting
 - A. Loosen or tighten the nut (picture C).

i The nut should not be so tight that the track steering control mechanism won't move or too loose so that the front wheel doesn't turn when using the track control steering mechanism.

- B. For fine track control steering adjustment, refer to [Adjusting the Track Control Steering Mechanism for Straights and Turns](#) on page 27.

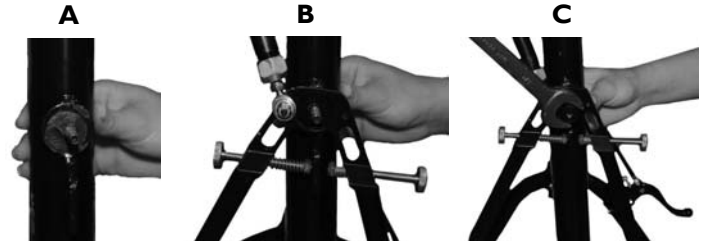

12 SERVICE PROCEDURES

12.10 Compensator Cylinder Replacement

1. Remove
 - A. Loosen and remove the nut (not shown) that attaches one end of the compensator cylinder to the track control steering mechanism.
 - B. Remove the bolt and nut (not shown) that attach the compensator cylinder to the clamp on the fork.
2. Replace
 - A. Put the end of the compensator cylinder in place on the clamp (picture A).
 - B. Put the screw into the mounting hole on the clamp (picture B).
 - C. Put a nut on the end of the screw and tighten securely with an Allen wrench (picture C).
 - D. Put the opposite end of the compensator cylinder in place on the track control steering mechanism and attach with a screw and nut (picture D). Tighten securely with an Allen wrench.



The racing wheelchair should be aligned straight after assembly. Refer to picture E. The clamp can be moved on the fork if necessary.

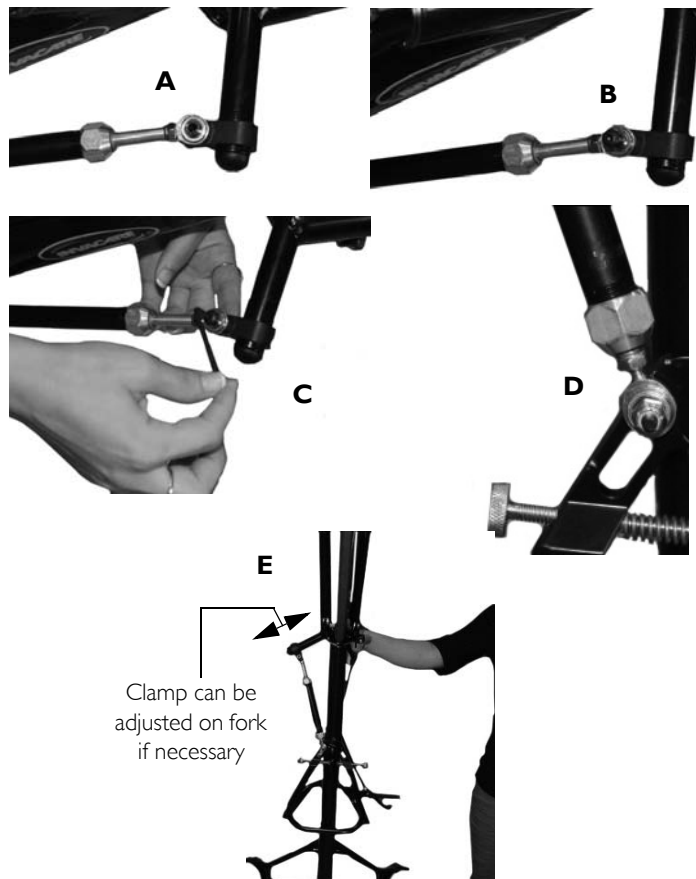

12.11 Assembling a Fork onto the Racing Wheelchair

i This procedure applies to either the Eliminator or the Preliminator racing chair.

1. Use an Allen key to remove the fork cap.
2. Remove the top three pieces of hardware (dust cap, race ring and a bearing) from the fork. The other race ring and a bearing must stay in place on the fork. **DO NOT** remove them.
3. Insert the fork into the frame headtube.
4. Put the bearing, race ring and dust cap onto the fork.
5. Put the steering handle onto the fork.

STEP 1



STEP 2



STEP 3



STEP 4



STEP 5



12 SERVICE PROCEDURES

6. Put the fork cap onto an Allen wrench.
7. Attach the fork cap to the fork. Tighten securely.
8. Put the compensator cylinder clamp onto the steering handle. Remove the screw from the compensator cylinder clamp with an Allen wrench.
9. Put the compensator cylinder and screw in place on the compensator cylinder clamp. Tighten the screw securely.

STEP 6



STEP 7



STEP 8



STEP 9



13 Options



WARNING

After any adjustments, repair or service and before use, make sure all attaching hardware is tightened securely. Otherwise injury or damage may occur.

13.1 Installing Safety Lights



WARNING

Operation of the racing chair is subject to all traffic rules and regulations (this may include the use of a safety lights and reflectors for dusk/night riding).

Batteries

1. Remove the lens cover.
2. Insert the AAA batteries with correct polarity (+ or -).
3. Reinstall lens cover.

Mounting the Safety Light

1. Remove the set screw from the clamp on the safety light.
2. Install the safety light.
 - A. Rear safety light: Pull the back cushion off of the back frame. Position the clamp onto the rear seat post. Install the set screw into the clamp and tighten securely.
 - B. Front safety light: Position the clamp onto the side frame. Install the set screw into the clamp and tighten securely.

Operating the Safety Light

1. Press the button to turn safety light on/off.
2. Remove lens cover and slide switch back and forth for pulse or constant mode.

13.2 Using Safety Helmet

1. Secure helmet using the chin strap.
2. Ensure proper fit.

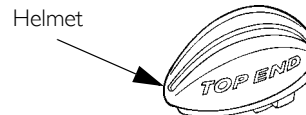

13 OPTIONS

13.3 Installing the Computer

1. Install metal plug onto spoke of the racing chair approximately 2 inches from wheel rim.
2. Align metal plug with fork assembly.
3. Secure sensor to fork using hardware provided.



Slot in sensor **MUST** align with metal plug for mileage, etc. to be registered on the computer.

4. Snap computer into mounting bracket.
5. Install spacer on the back of the computer mounting bracket.
6. Secure mounting bracket to racing chair with zip or wire ties.

13.4 Assembling/Adjusting/Using the Bike Rack



WARNING

After any adjustments, repair or service and before use, make sure all attaching hardware is tightened securely. Otherwise injury or damage may occur.

Assembling the Bike Rack

1. Position the receiver with the bracket facing up.
2. Position the rear wheel bar with the wheel brackets facing up.
3. Remove the two large mounting bolts and locknuts from the receiver and set aside.
4. Remove the two small mounting bolts and locknuts from the receiver bracket and set aside.
5. Secure the wheel tray to the receiver with the two large mounting bolts and locknuts.
6. Using two small mounting bolts and locknuts, secure the receiver bracket to the wheel tray.
7. Remove the two mounting bolts and locknuts from the rear wheel bar and set aside.
8. Using two mounting bolts and locknuts, secure the rear wheel bar to the wheel tray.
9. Install the receiver onto the trailer hitch of the vehicle, according to the vehicle manufacturer's instructions.

Adjusting the Bike Rack



WARNING

After any adjustments, repair or service and before use, make sure all attaching hardware is tightened securely. Otherwise injury or damage may occur.



To properly secure the racing chair, the wheel tray bracket should be adjusted to sit against the front wheel.

Wheel Tray Bracket

1. Remove the four mounting bolts and locknuts securing the wheel tray bracket to the wheel tray.
2. Position the wheel tray bracket in the desired position.
3. Secure the wheel tray bracket to the wheel tray with the four mounting bolts and locknuts.
4. If necessary, the wheel stop may be adjusted to one of three positions to sit against the front wheel. To adjust the wheel stop, perform the following steps:
 - A. Remove the mounting bolt and locknut securing the wheel stop to the wheel tray bracket.
 - B. Position the wheel stop in the desired mounting position.
 - C. Secure the wheel stop to the wheel tray bracket with the mounting bolt and locknut.

Rear Wheel Bar Brackets



To properly secure the racing chair, the rear wheel bar brackets should be adjusted to sit against the rear wheels.

1. Loosen the two screws securing the rear wheel bar bracket to the rear wheel bar.
2. Adjust the rear wheel bar bracket in/out until they sit against the rear wheel.
3. Secure the rear wheel bar bracket to the rear wheel bar with the two screws.
4. Repeat steps 1-3 for the opposite side if necessary.

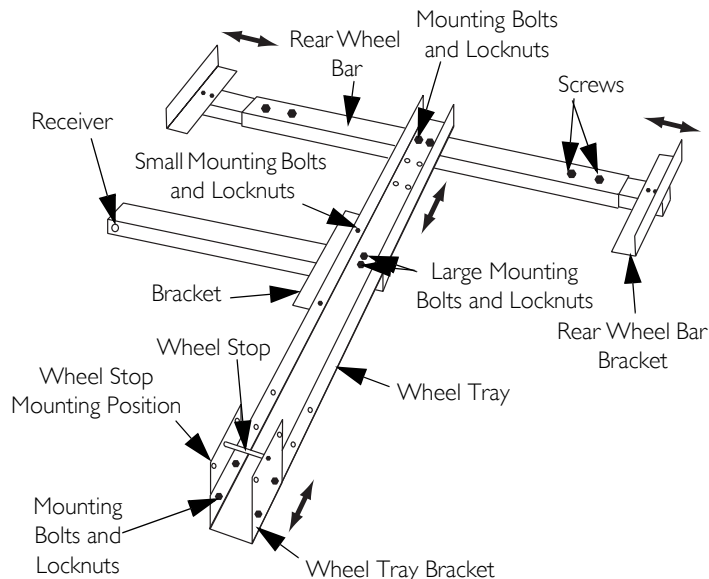

13 OPTIONS

Rear Wheel Bar



To properly secure the racing chair, the rear wheel bar should be adjusted so the rear wheels sit in the rear wheel bar brackets.

1. Remove the two mounting bolts and locknuts securing the rear wheel bar to the wheel tray.
2. Position the rear wheel bar to one of three mounting positions on the wheel tray.
3. Secure the rear wheel bar to the wheel tray with the two mounting bolts and locknuts.

Using the Bike Rack

1. Position the racing chair on the rack with the front wheel in the wheel tray bracket.
2. Adjust the bike rack so the wheel tray bracket sits against the front wheel and the rear wheel bar brackets sit against the rear wheels.
3. Secure the front wheel to the wheel tray bracket using the strap provided.
4. Secure the rear wheels to the rear wheel bar using the straps provided.

13.5 Using the Alignment Gauge

1. Inflate the tires to recommended tire pressures (listed on the sidewall of the tire).
2. Place the racing chair and alignment gauge on a flat surface.
3. Position the alignment gauge near the rear of the rear tires.
4. Loosen the alignment screw on each side.
5. Position the alignment gauge between the rear of the rear tires.
6. Adjust the alignment inserts so the alignment gauge fits snugly between the rear of the rear tires.
7. Tighten the alignment screws to secure the alignment bar position.
8. Position the alignment gauge at the front of the rear tires and repeat.
9. Examine the gauge. Perform one of the following:
 - A. If the alignment gauge fits snugly between the front of the rear tires, the wheels are aligned. No toe in/toe out adjustment is required.
 - B. If there is extra space between the alignment gauge and rear tires, the tires have a toe out condition. Refer to [Adjusting Toe In/Toe Out](#) on page 33.
 - C. If the alignment gauge does not fit between rear tires, the tires have a toe in condition. Refer to [Adjusting Toe In/Toe Out](#) on page 33.



Alignment Gauge

Front of Racing Chair

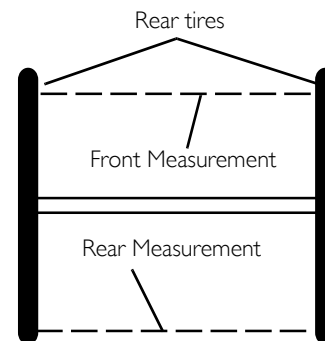

Rear of Racing Chair

13.6 Additional Options



These options are available for order through www.topendwheelchair.com or 1-800-532-8677.

A - Heart rate monitor

The monitor is usually mounted on the crank assembly.

The user attaches the heart rate monitor around his/her chest with a strap that is included with this option.

B - Click Strap

Attach with heavy duty zip ties to the cage.

C - Wheel Bag

Wheel bag can fit up to three wheels.

Remove and place axles in the bottom of the wheel bag to ensure they are not damaged.

D - Plastic Footplate with Strap

E - Fixed Footrest

F - Cushion

G - Safety Flag

Mount safety flag in holder secured to back tube on racing chair frame.

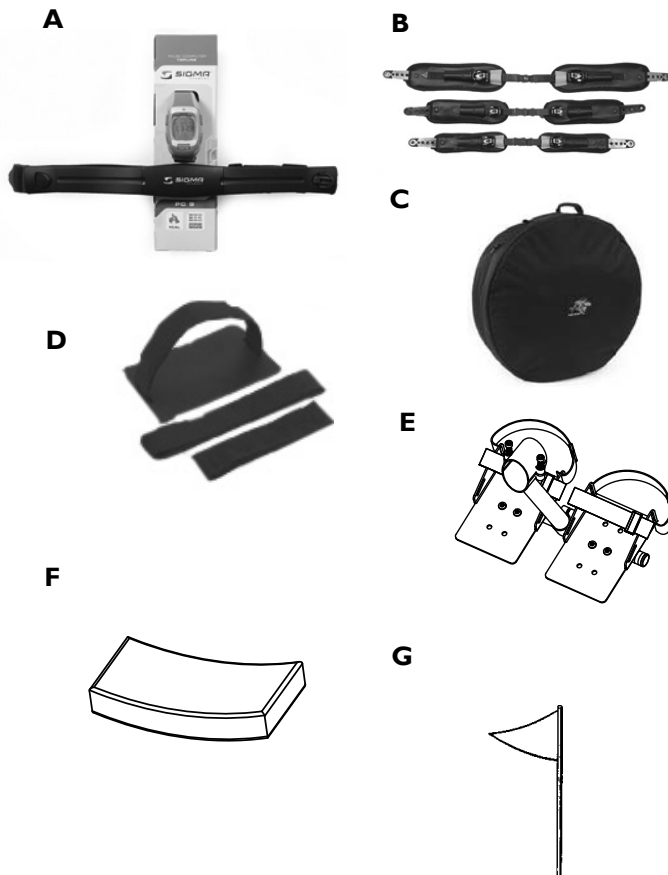

13 OPTIONS

H - Indoor Training Roller

Check all parts for shipping damage. In case of damage, DO NOT use. Contact Carrier/Invacare for further instructions.

To ensure the safe assembly and use of the indoor training roller, these instructions must be followed:

Setup

1. Remove the Indoor Training Roller from packaging.
2. Slide the clip into the bottom or side of the base. Tighten loosely.
3. Align and put the base onto the mounting bolts on the roller.
4. Tighten the mounting bolts with an allen wrench.
5. Move the tensioner to the desired position. Tighten securely.
6. To place the racing chair onto the Indoor Training Roller, loosen and remove the allen screws. Remove the top half of the clamp. Put an empty racing chair onto the Indoor Training Roller. Attach the top half of the clamp over the racing chair frame.

STEP 1



STEP 2

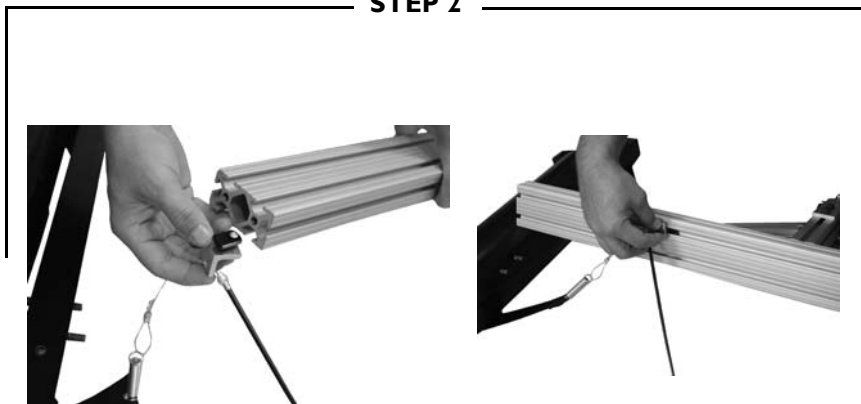

STEP 3



STEP 4



STEP 5

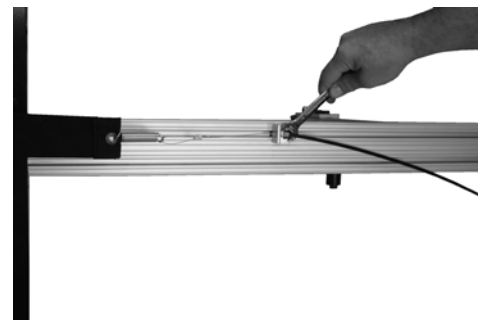

STEP 6



Invacare Corporation

www.invacare.com and www.topendchair.com

USA

One Invacare Way
Elyria, Ohio USA
44035
800-333-6900



Manufactured by:
Top End Sports and Recreation Products
4501 63rd Circle North
Pinellas Park, Florida
33781-5914
(727) 522-8677
(800) 532-8677

Part No I052767

Rev D-01 12/27/16



Making Life's Experiences Possible®



Yes, you can.®